

CLARK TOWNSHIP
N.W. QTR. SECTION 2
T-8 N; R-5 W
HOLMES COUNTY, OHIO

SURVEYED FOR: ADEN R. MILLER

REFERENCES:
DEED VOL. 176 PAGE 357
DEED VOL. 237 PAGE 42
O.R. VOL. 25 PAGE 344
PLAT VOL. 4 PAGE 92
PLAT VOL. 10 PAGE 851
BEARINGS ASSUMED.

200400034389
PAUL A
MILLER LAW
MILLERSBURG, OH

200400034389
Filed for Record in
HOLMES COUNTY, OH
SALLY MILLER
12-16-2004 At 12:48 pm.
SMALL PLAT 40.00
OR Book 19 Page 277 - 277
ORV 177 page 410

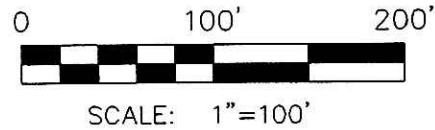

- 5/8" REBAR FOUND
- 5/8" REBAR WITH I.D. CAP SET
I.D. CAP MARKED "BAKER 6938"

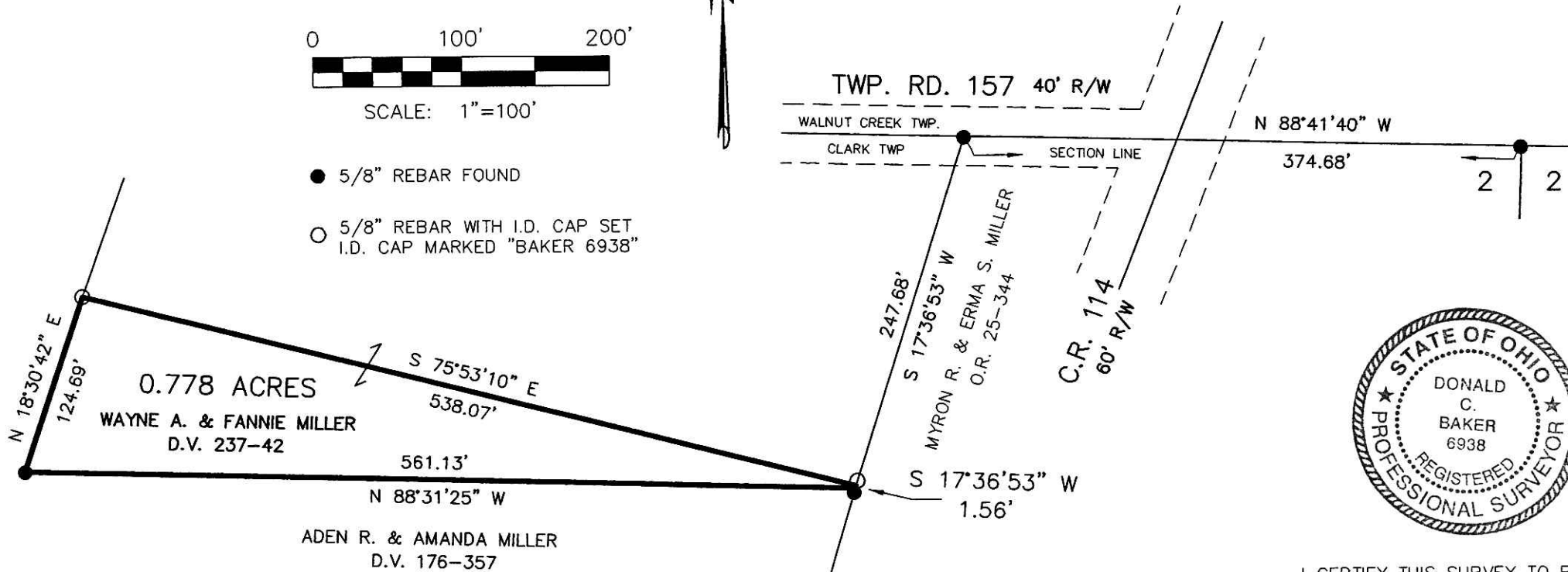

I CERTIFY THIS SURVEY TO BE CORRECT
TO THE BEST OF MY KNOWLEDGE.

Donald C. Baker
DONALD C. BAKER PS 6938
DATE: SEPT. 29, 2003
FDB\AEG
File Name: C:\WORK\S-843-03\ERZ
(S-3 Data: S-151-03)



DONALD C. BAKER SURVEYING
138 N. CLAY ST.
MILLERSBURG, OH 44654
PH. 330-674-4788
FAX: 330-674-6027

APPROVED FOR TRANSFER ONLY
NO SUBDIVISION PLAT REQUIRED
(O.R.C. 711.001 & 711.131)
Lot(s) not for building unless
approved by Board of Health.
HOLMES CO. PLANNING COMM.

By *mh* Date *12/15/04*

PLAT APPROVED

12/14/2004

Instrument 200400034389 OR Book Page 19 277