

SUBDIVISION VACATION PLAT
LOT 2 of the SECHRIEST SUBDIVISION
AS RECORDED IN P.V. 17-769

HARDY TOWNSHIP
1ST. QTR., LOT 8
T-9N; R-7W
HOLMES COUNTY, OHIO

REFERENCES:

- DEED VOL. 266 PAGE 949
- O.R. VOL. 62 PAGES 714 & 718
- O.R. VOL. 71 PAGES 2 & 77
- PLAT VOL. 2 PAGE 236
- PLAT VOL. 14 PAGE 662
- PLAT VOL. 16 PAGE 532
- PLAT VOL. 17 PAGES 700, 769 & 833

BEARINGS FROM PLAT VOL. 17 PAGE 769

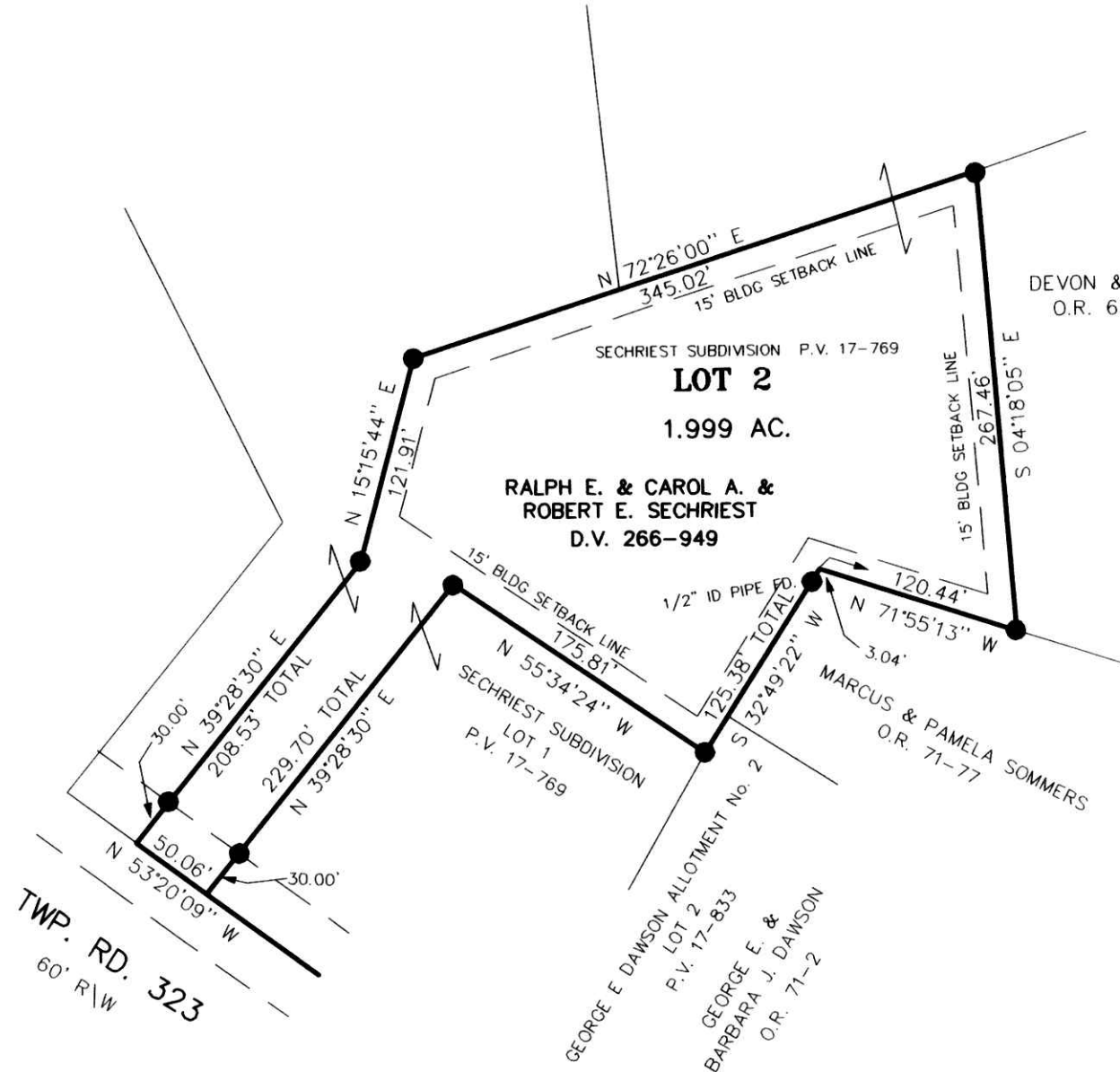
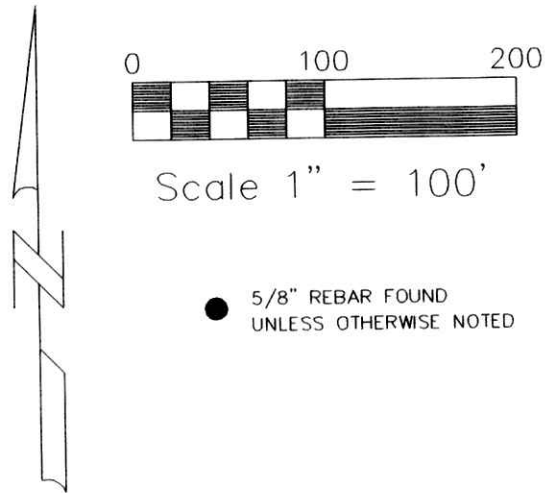

We, the undersigned, being all of the record title owners of all lots in the Sechriest Subdivision, Hardy Township, First Quarter, Lot 8, Township 9 North, Range 7 West, Holmes County, Ohio (original plat recorded at Holmes County Plat Volume 17 Page 769) do hereby approve and consent to the vacation of Lot 2, owned by Ralph E. Sechriest, Carol A. Sechriest and Robert E. Sechriest (acquired at Holmes County Deed Volume 266 Page 949) as further described hereon. The herein consent and approval to the proposed vacation of Lot 2 is subject to the condition that said real estate is surveyed and described as a 0.592 acre parcel and the remainder platted as Lot 3 of the Sechriest Subdivision recorded in Plat Vol. 12 Page 120

We hereby certify that we are the owners of the property shown and described hereon and that we hereby adopt this plan of vacation with our free consent.

Ralph E. Sechriest 8-28-03
 Ralph E. Sechriest Date
Carol A. Sechriest 8/28/03
 Carol A. Sechriest Date
Robert E. Sechriest 9-30-03
 Robert E. Sechriest Date
 by *Ralph E. Sechriest POA* 9-30-03

200300027673
 FRENCH RIDGE
 TITLE
 MILLERSBURG, OH

200300027673
 Filed for Record in
 HOLMES COUNTY, OH
 SALLY MILLER
 12-02-2003 At 03:05 pm.
 SMALL PLAT 40.00
 OR Book 18 Page 818 - 818

INDEXED

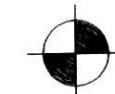

 **DONALD C. BAKER SURVEYING**
138 N. CLAY ST.
MILLERSBURG, OHIO 44654
PH. 330-674-4788
FAX 330-674-6027

I CERTIFY THIS SURVEY TO BE CORRECT TO THE BEST OF MY KNOWLEDGE.

Donald C. Baker
 DONALD C. BAKER P.S. 6938
 DATE: JULY 22, 2003.

File name: C:\JOBS\S-496A-03\ERZ

TRANSFER NOT NECESSARY
 DATE *12-2-03 Kbb*
 AUDITOR *Jackie Moore*

Instrument 200300027673 OR Book Page 18 818