

REFERENCES:

DEED VOL. 191 PAGE 651  
DEED VOL. 165 PAGE 567  
DEED VOL. 147 PAGE 295

BEARINGS FROM PLAT VOL. 7 PAGE 505

WALNUT CREEK TOWNSHIP  
N.E. QTR. SECTION 24  
T-9N ; R-4W  
HOLMES COUNTY, OHIO

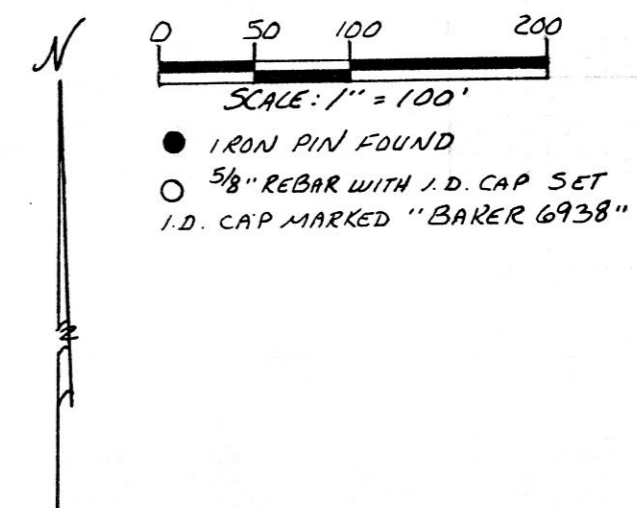

LAURA E. MACHAN  
147-295

JOHN B. & MARY ELLEN TROYER  
191-651

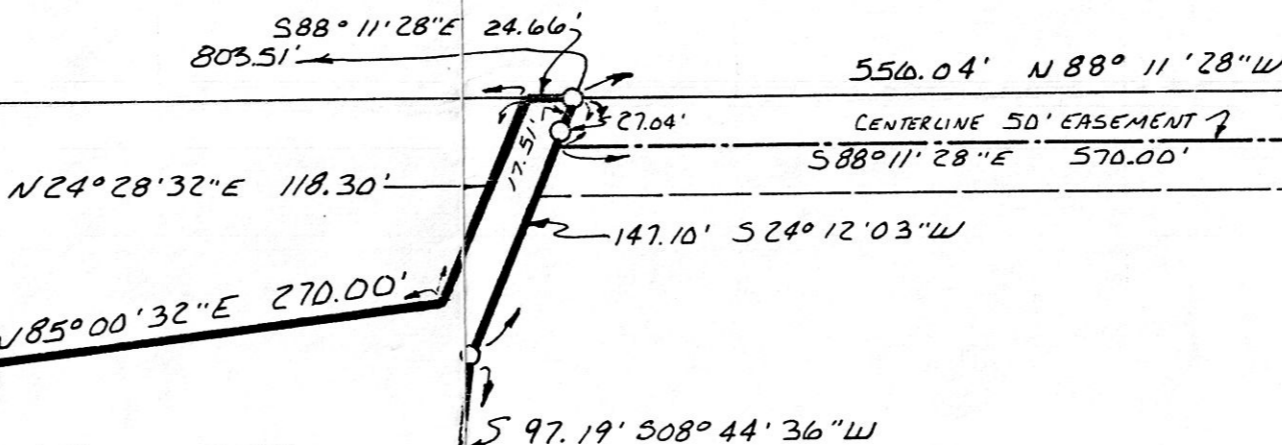

**2.212 ACRES**

THIS PARCEL TO BE ANNEXED  
TO JOHN B. & MARY ELLEN TROYER'S

BEN A. & MABEL TROYER  
165-567

APPROVED FOR TRANSFER ONLY  
NO SUBDIVISION PLAT REQUIRED  
(O.R.C. 711.001 & 711.131)  
Lot(s) not for building unless  
approved by Board of Health.  
HOLMES CO. PLANNING COMM.

By TPM Date 7-11-95

193421

REC'D  
AT 10:44 o'clock A.M.

RECORDED  
FEE \$20.00

INDEXED

JUL 13 '95

JUL 14 '95

Plat  
VOL 14 PAGE 852  
OV 269 pg 386

Sally Miller  
RECORDER  
Jarrett

I CERTIFY THIS SURVEY TO BE CORRECT  
TO THE BEST OF MY KNOWLEDGE.

Donald C. Baker  
DONALD C. BAKER P.S. 6938  
4321 T.R. 252  
GLENMONT, OHIO 44628

JUNE 5, 1991

PLAT APPROVED

1723-MCS

7/14/95 Rg

