

STATE OF OHIO DEPARTMENT OF TRANSPORTATION

HOL-39/754-11.17/0.16, TUS-93-10.80

MONROE TOWNSHIP
WAYNE TOWNSHIP
HOLMES COUNTY
TUSCARAWAS COUNTY

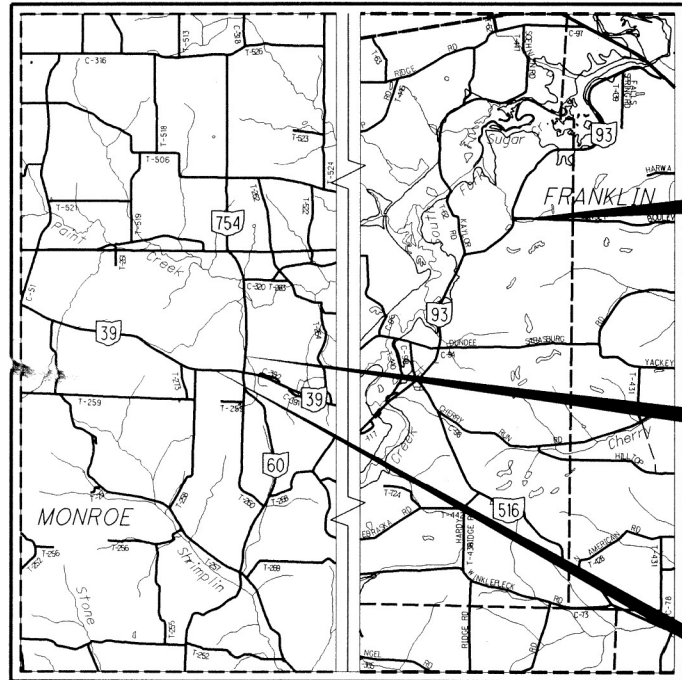

LOCATION MAP

LATITUDE: 40°34'35" LONGITUDE: -82°01'45" (HOL-39-11.17)
 LATITUDE: 40°34'45" LONGITUDE: -82°01'15" (HOL-754-0.16)
 LATITUDE: 40°36'40" LONGITUDE: -81°35'20" (TUS-93-10.80)

PORTION TO BE IMPROVED	—————
INTERSTATE HIGHWAY	—————
FEDERAL ROUTES	—————
STATE ROUTES	—————
COUNTY & TOWNSHIP ROADS	—————
OTHER ROADS	—————

DESIGN DESIGNATION

	HOL-39-11.17	HOL-754-0.16	TUS-93-10.80
CURRENT ADT (2023)	7300	2700	1400
DESIGN YEAR ADT (2043)	9500	3000	1600
DESIGN HOURLY VOLUME (2043)	950	300	200
DIRECTIONAL DISTRIBUTION	0.53	0.60	0.52
TRUCKS (24 HOUR B&C)	0.09	0.09	0.12
DESIGN SPEED	55 MPH	55 MPH	55 MPH
LEGAL SPEED	55 MPH	55 MPH	55 MPH
DESIGN FUNCTIONAL CLASSIFICATION:			
04 MINOR ARTERIAL (RURAL) - HOL-39-11.17			
05 MAJOR COLLECTOR (RURAL) - HOL-754-0.16			
05 MAJOR COLLECTOR (RURAL) - TUS-93-10.80			
NHS PROJECT	NO		

DESIGN EXCEPTIONS

DESIGN FEATURE	APPROVAL DATES	SHEET NUMBER
HORIZONTAL ALIGNMENT:		
CURVE RADIUS (TUS-93-10.77)	08/27/2021	44
SUPERELEVATION RATE (TUS-93-10.77)	08/27/2021	6

ADA DESIGN WAIVER: NONE REQUIRED

PLAN PREPARED BY:
 BG ENGINEERING GROUP, LLC
 5910 WILCOX PLACE, SUITE C
 DUBLIN, OHIO 43016

ENGINEER'S SEAL:

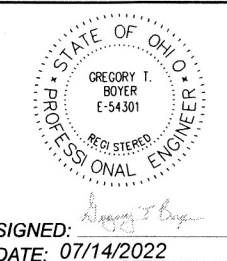

INDEX OF SHEETS:

TITLE SHEET	1	PLAN AND PROFILE - S.R. 39	44
TYPICAL SECTIONS	2-7	ESTIMATED QUANTITIES - S.R. 93	45
GENERAL NOTES	8-9	CROSS SECTIONS - S.R. 93	46-51
MAINTENANCE OF TRAFFIC	10-16	SUPERELEVATION TABLES	52
GENERAL SUMMARY	17-19	DRIVE DETAILS - S.R. 39	53
PROJECT SITE PLAN	20	INTERSECTION DETAILS - S.R. 93	54
PLAN AND PROFILE - S.R. 39	21-22	TRAFFIC CONTROL	55-56
ESTIMATED QUANTITIES - S.R. 39	23	STRUCTURE 20 FOOT SPAN AND UNDER	
CROSS SECTIONS - S.R. 39	24-31	HOL-00039-11.176	57-64
PLAN AND PROFILE - S.R. 754	32	HOL-00754-00.169	65-71
ESTIMATED QUANTITIES - S.R. 754	33	TUS-00093-10.809	72-77
CROSS SECTIONS - S.R. 754	34-40	RIGHT OF WAY	78-90
DRIVE DETAILS - S.R. 754	41-42	SOIL PROFILE - CULVERT	91-93
STORM SEWER PROFILE - S.R. 754	43		

ATTENTION
 Contact the Ohio Department
 of Transportation for current
 Plans of Record

UNDERGROUND UTILITIES

Contact Two Working Days
 Before You Dig



OHIO811, 8-1-1, or 1-800-362-2764
 (Non-members must be called directly)

STANDARD CONSTRUCTION DRAWINGS						SUPPLEMENTAL SPECIFICATIONS	SPECIAL PROVISIONS
BP-3.1	1-21-22	MGS-1.1	7-16-21	RM-1.1	1-15-21	800-2019	10-21-22
BP-4.1	7-19-13	MGS-2.1	1-19-18	RM-4.2	4-17-20	821	4-20-12
		MGS-2.3	7-18-14			832	10-19-18
CB-2-3	7-16-21	MGS-4.3	1-18-13	TC-41.20	10-18-13	902	7-19-19
		MGS-5.2	7-15-16	TC-41.30	10-18-13	921	4-20-12
DM-1.1	7-17-20	MGS-5.3	7-15-16	TC-42.20	10-18-13	940	4-17-15
DM-4.3	1-15-16	MT-95.45	1-17-20	TC-52.10	10-18-13	961	4-17-20
DM-4.4	1-15-16	MT-96.11	4-16-21	TC-52.20	1-15-21		
		MT-96.20	7-15-16	TC-61.30	7-19-19		
HW-2.1	7-20-18	MT-96.26	1-18-19	TC-65.10	1-17-14		
HW-2.2	7-20-18	MT-97.10	4-19-19	TC-65.11	7-21-17		
		MT-101.60	1-17-20	TC-71.10	7-16-21		
		MT-101.70	1-17-20				
		MT-101.75	1-17-20				
		MT-101.90	7-17-20				
		MT-105.10	1-17-20				

FEDERAL PROJECT NUMBER

E200 (558)

RAILROAD INVOLVEMENT

NONE

PROJECT DESCRIPTION

REPLACEMENT OF THREE EXISTING CULVERTS:
 HOL-00039-11.176, HOL-00754-0.169, AND TUS-00093-10.809
 INCLUDING MINOR ROADWAY PAVEMENT REPLACEMENT

EARTH DISTURBED AREAS

HOL-39-11.17	
PROJECT EARTH DISTURBED AREA:	1.00 ACRES
ESTIMATED CONTRACTOR EARTH DISTURBED AREA:	0.09 ACRES
NOTICE OF INTENT EARTH DISTURBED AREA:	1.09 ACRES
HOL-754-0.16	
PROJECT EARTH DISTURBED AREA:	0.80 ACRES
ESTIMATED CONTRACTOR EARTH DISTURBED AREA:	0.09 ACRES
NOTICE OF INTENT EARTH DISTURBED AREA:	N/A (NOI NOT REQUIRED)
TUS-93-10.80	
PROJECT EARTH DISTURBED AREA:	0.50 ACRES
ESTIMATED CONTRACTOR EARTH DISTURBED AREA:	0.13 ACRES
NOTICE OF INTENT EARTH DISTURBED AREA:	N/A (NOI NOT REQUIRED)

2019 SPECIFICATIONS

THE STANDARD SPECIFICATIONS OF THE STATE OF OHIO, DEPARTMENT OF TRANSPORTATION, INCLUDING SUPPLEMENTAL SPECIFICATIONS LISTED IN THE PLANS AND CHANGES LISTED IN THE PROPOSAL SHALL GOVERN THIS IMPROVEMENT.

I HEREBY APPROVE THESE PLANS AND DECLARE THAT THE MAKING OF THIS IMPROVEMENT WILL REQUIRE THE CLOSING TO TRAFFIC OF THE HIGHWAY AND THAT THE DETOURS WILL BE PROVIDED AS INDICATED ON SHEETS 15 AND 16.

APPROVED _____
 DATE _____ DISTRICT DEPUTY DIRECTOR

APPROVED _____
 DATE _____ DIRECTOR, DEPARTMENT OF
 TRANSPORTATION

TITLE SHEET

DESIGN AGENCY	BG ENGINEERING GROUP, LLC
DESIGNER	JEP
REVIEWER	RG
PROJECT ID	111666
SHEET TOTAL	1 93

HOL-39/754-11.17/0.16, TUS-93-10.80

MODEL: Sheet PAPER SIZE: 17x11 (in.) DATE: 7/14/2022 TIME: 1:00:53 PM C:\Users\jperchinska\OneDrive\Documents\Transportation\Work\Seals\111666_HOL-39-1118\400-Engineering\Roadway\Sheets\111666_HOL-39-1118_GT001.dgn

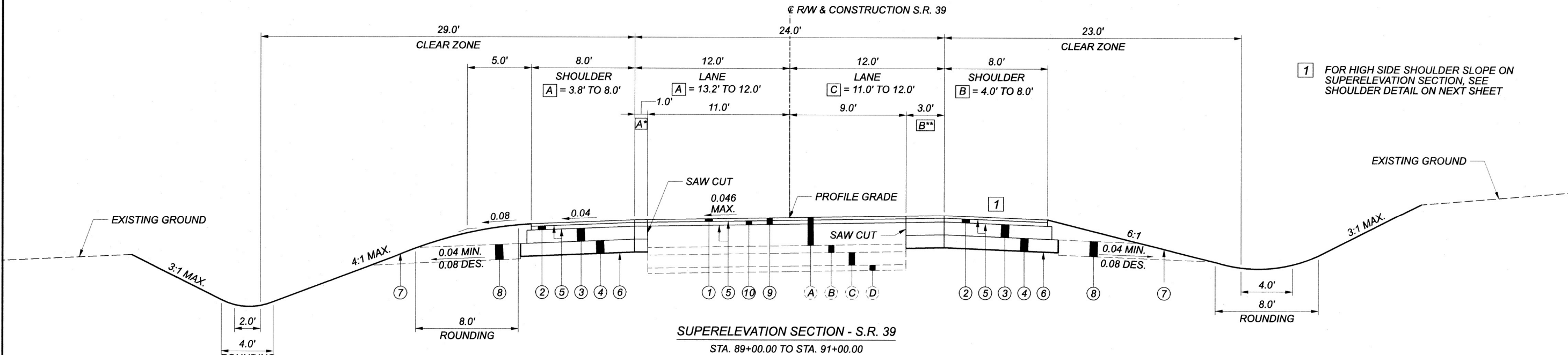
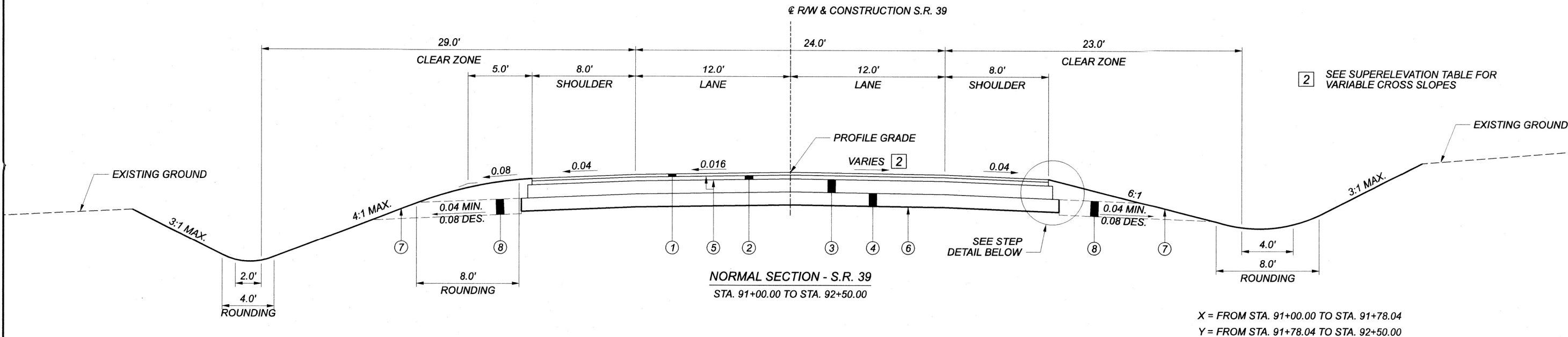

NOTE "A"
 PAVEMENT PLANING SHALL BE A MINIMUM DEPTH OF 3" AT THE CL OF CONSTRUCTION WITH THE CROSS SLOPE MATCHING THE EXISTING CROSS SLOPE.

LEGEND

- | | | |
|---|---|---------------------|
| ① ITEM 441 - 1.25" ASPHALT CONCRETE SURFACE COURSE, TYPE 1, (449), AS PER PLAN (PG70-22M) | ⑥ ITEM 204 - SUBGRADE COMPACTION | Ⓐ 13"± ASPHALT |
| ② ITEM 441 - 1.75" ASPHALT CONCRETE INTERMEDIATE COURSE, TYPE 2, (449) | ⑦ ITEM 659 - SEEDING AND MULCHING | Ⓑ 3.5"± BRICK |
| ③ ITEM 301 - 6" ASPHALT CONCRETE BASE, PG64-22 (449) | ⑧ ITEM 605 - AGGREGATE DRAINS | Ⓒ 6"± CONCRETE |
| ④ ITEM 304 - 6" AGGREGATE BASE | ⑨ ITEM 254 - PAVEMENT PLANING, (ASPHALT CONCRETE) (SEE NOTE "A") | Ⓓ 2.5"± BASE COURSE |
| ⑤ ITEM 407 - TACK COAT | ⑩ ITEM 441 - ASPHALT CONCRETE INTERMEDIATE COURSE, TYPE 2, (449) (VARIABLE THICKNESS) | |

Ⓐ = STA. 89+50.00 TO STA. 90+00.00
 * = VARIES 2.2' TO 1.0'
 ** = VARIES 2.0' TO 3.0'
 Ⓑ = STA. 89+00.00 TO STA. 90+00.00
 Ⓒ = STA. 89+50.00 TO STA. 90+00.00

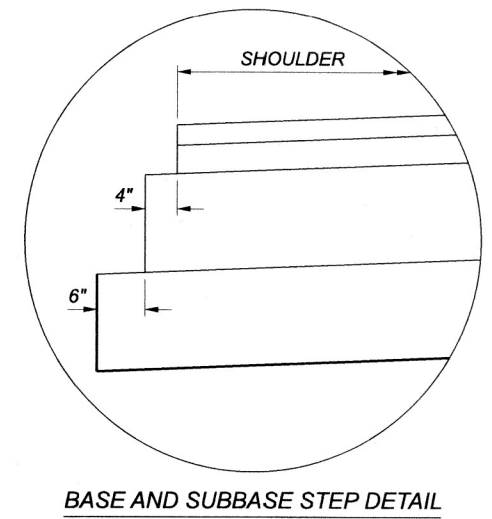

DESIGN AGENCY
B.G.
 www.bggroup.com
 5910 WILCOX PLACE, SUITE C
 DUBLIN, OHIO 43016

DESIGNER
 JEP

REVIEWER
 RG 7-14-22

PROJECT ID
 111666

SHEET TOTAL
 2 93

SEE SHEET 2 FOR LEGEND.

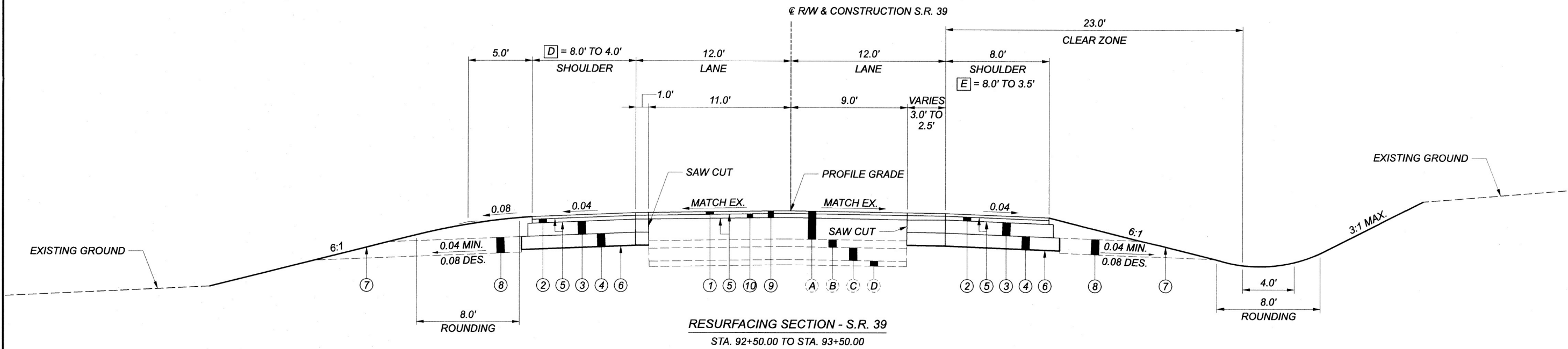

D = STA. 92+50.00 TO STA. 92+75.00

E = STA. 92+75.00 TO STA. 93+50.00

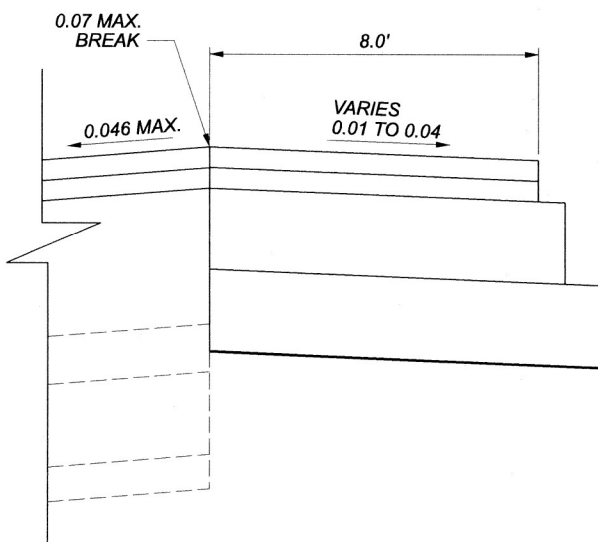

SHOULDER DETAIL 1

APPLIES TO PAVEMENT SLOPE OF 0.06 OR LESS

HIGH SIDE SHOULDER

HOL-39/754-11.17/0.16, TUS-93-10.80

MODEL: Sheet PAPER SIZE: 17x11 (in.) DATE: 7/14/2022 TIME: 1:01:33 PM USER: JPerchinske
 P:\Transportation\Worksets\111666_HOL_39-11\18400-Engineering\Roadway\Sheets\111666_HOL_39-1118_GY001.dgn

TYPICAL SECTIONS - S.R. 39

DESIGN AGENCY
B.G.
 www.bggroup.com
 5910 WILCOX PLACE, SUITE C
 DUBLIN, OHIO 43016

DESIGNER	JEP
REVIEWER	RG
PROJECT ID	111666
SHEET	TOTAL
3	93

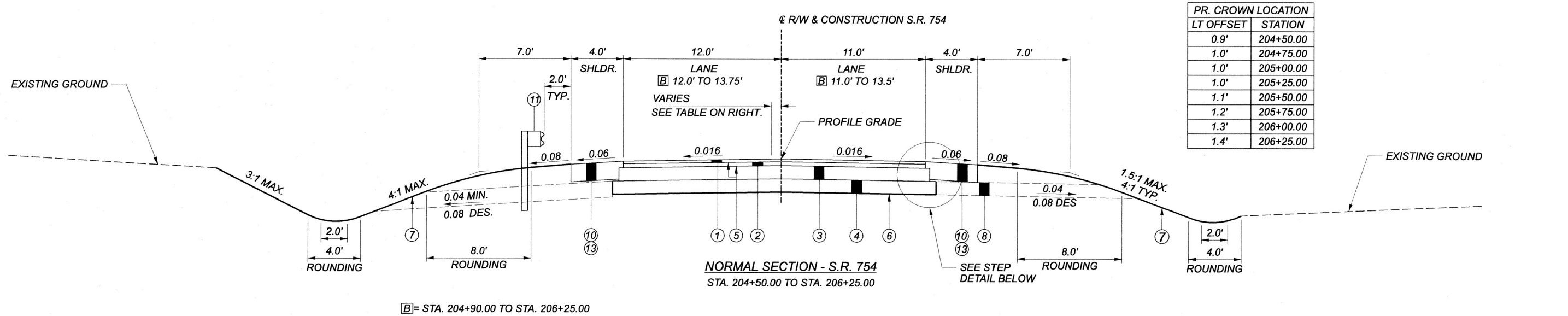

PR. CROWN LOCATION	
LT OFFSET	STATION
0.9'	204+50.00
1.0'	204+75.00
1.0'	205+00.00
1.0'	205+25.00
1.1'	205+50.00
1.2'	205+75.00
1.3'	206+00.00
1.4'	206+25.00

EX. CROWN LOCATION	
LT OFFSET	STATION
0.4'	202+75.00
0.5'	203+00.00
0.8'	203+25.00
0.9'	203+50.00
1.0'	203+75.00
0.9'	204+00.00
0.9'	204+25.00
0.9'	204+50.00

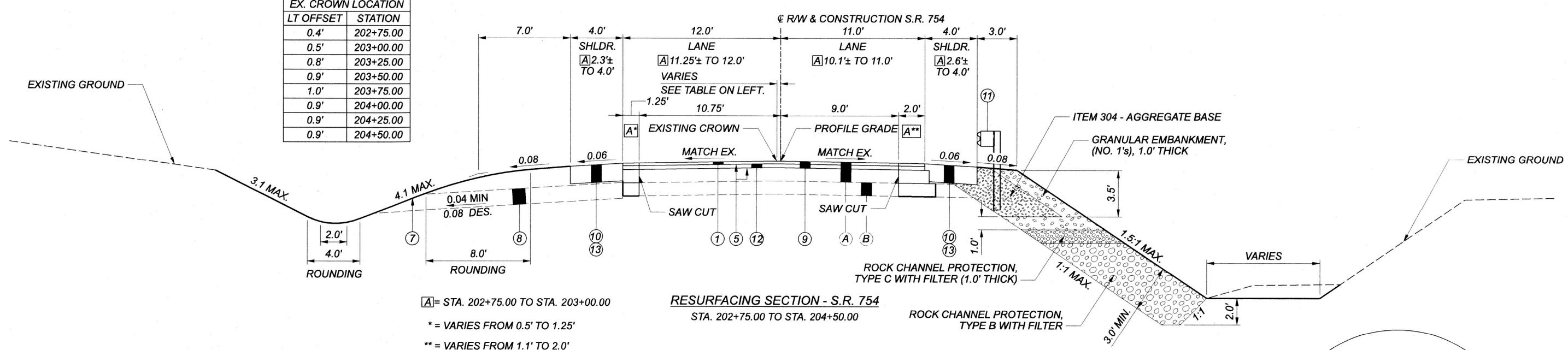

NOTE "A"
 PAVEMENT PLANING SHALL BE A MINIMUM DEPTH OF 3" AT THE @ OF CONSTRUCTION WITH THE CROSS SLOPE MATCHING THE EXISTING CROSS SLOPE.

LEGEND

- ① ITEM 441 - 1.25" ASPHALT CONCRETE SURFACE COURSE, TYPE 1, (449), AS PER PLAN (PG70-22M)
- ② ITEM 441 - 1.75" ASPHALT CONCRETE INTERMEDIATE COURSE, TYPE 2, (449)
- ③ ITEM 301 - 6" ASPHALT CONCRETE BASE, PG64-22 (449)
- ④ ITEM 304 - 6" AGGREGATE BASE
- ⑤ ITEM 407 - TACK COAT
- ⑥ ITEM 204 - SUBGRADE COMPACTION
- ⑦ ITEM 659 - SEEDING AND MULCHING
- ⑧ ITEM 605 - AGGREGATE DRAINS
- ⑨ ITEM 254 - PAVEMENT PLANING, (ASPHALT CONCRETE) (SEE NOTE "A")
- ⑩ ITEM 304 - 8" AGGREGATE BASE
- ⑪ ITEM 606 - GUARDRAIL, TYPE MGS
- ⑫ ITEM 441 - ASPHALT CONCRETE INTERMEDIATE COURSE, TYPE 2, (449) (VARIABLE THICKNESS)
- ⑬ ITEM 408 - PRIME COAT, AS PER PLAN
- Ⓐ 12%± ASPHALT
- Ⓑ 6%± BASE COURSE

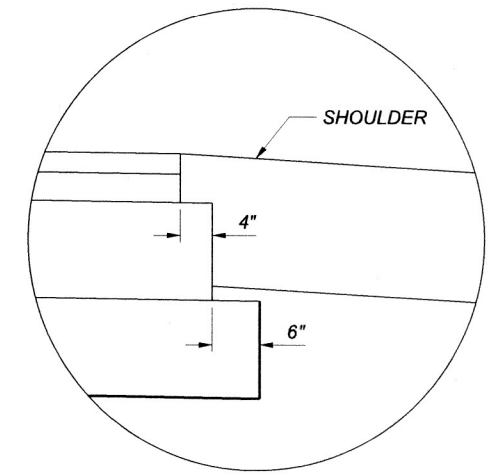

SEE SHEET 4 FOR LEGEND.

EX. CROWN LOCATION	
LT OFFSET	STATION
1.4'	206+25.00
1.3'	206+50.00
1.3'	206+75.00
1.3'	207+00.00

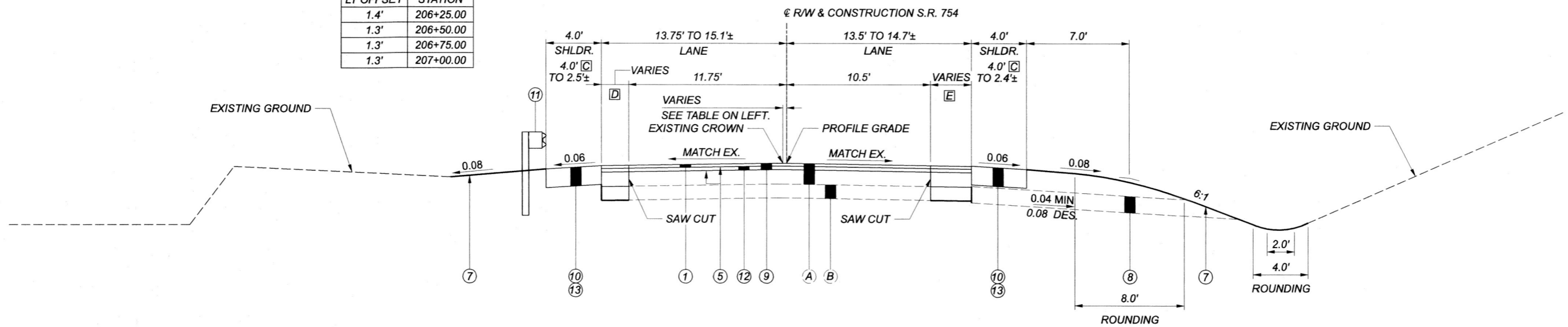

- C** = STA. 206+75.00 TO STA. 207+00.00
- D** = 2.0' TO 3.4'
- E** = 3.0' TO 4.2'

RESURFACING SECTION - S.R. 754
 STA. 206+25.00 TO STA. 207+00.00

HOL-39/754-11.17/0.16, TUS-93-10.80

MODEL: Sheet PAPER SIZE: 17x11 (in.) DATE: 7/14/2022 TIME: 1:01:55 PM USER: JPerchinski
 P:\Transportation\Work\11666_HOL-39-118\400-Engineering\Roadway\Sheets\11666_HOL-754-0018_GY201.dgn

TYPICAL SECTIONS - S.R. 754

DESIGN AGENCY

 www.bginquiry.com
 8910 WILCOX PLACE, SUITE C
 DUBLIN, OHIO 43016

DESIGNER
 JEP

REVIEWER
 RG 6-8-22

PROJECT ID
 111666

SHEET TOTAL
 5 93

1 FOR HIGH SIDE SHOULDER SLOPE ON SUPERELEVATION SECTION, SEE SHOULDER DETAIL ON THIS SHEET

◇ NDC = 0.08
ACTUAL DESIGN SPEED = <25MPH

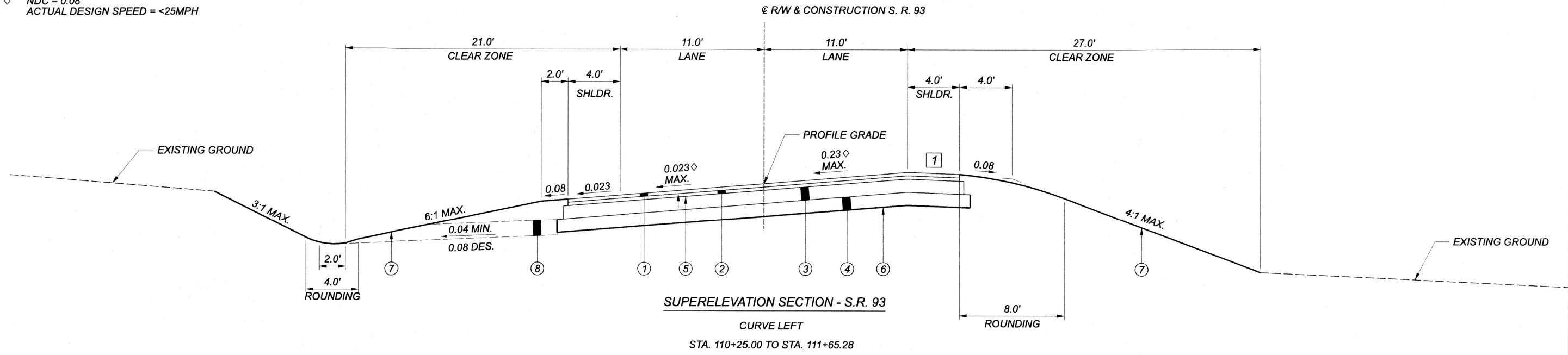

EX. CROWN LOCATION	
STATION	RT OFFSET
108+50.00	1.8'
108+75.00	1.9'
109+00.00	0.9'
109+22.00	0.0'

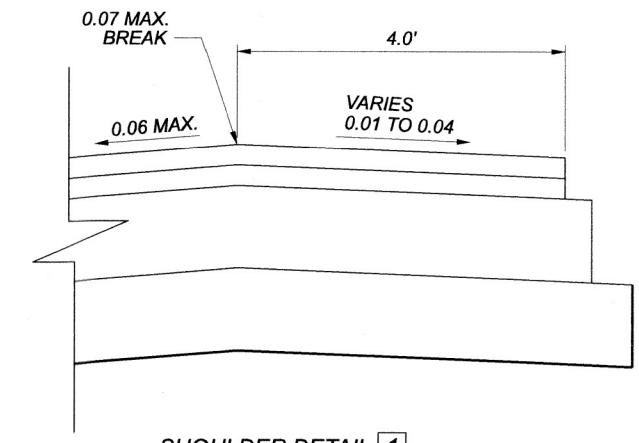
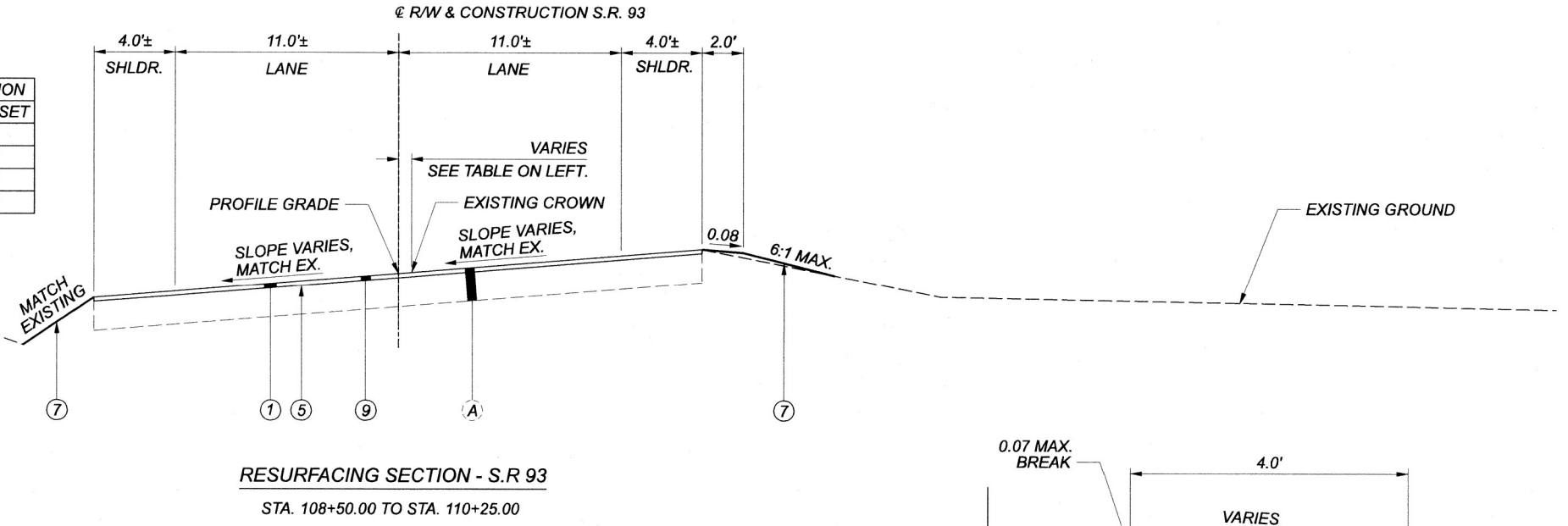

NOTE "A"

PAVEMENT PLANING SHALL BE A MINIMUM DEPTH OF 1.25" AT THE © OF CONSTRUCTION WITH THE CROSS SLOPE MATCHING THE EXISTING CROSS SLOPE.

LEGEND

- ① ITEM 441 - 1.25" ASPHALT CONCRETE SURFACE COURSE, TYPE 1, (449), AS PER PLAN (PG70-22M)
- ② ITEM 441 - 1.75" ASPHALT CONCRETE INTERMEDIATE COURSE, TYPE 2, (449)
- ③ ITEM 301 - 6" ASPHALT CONCRETE BASE, PG64-22 (449)
- ④ ITEM 304 - 6" AGGREGATE BASE
- ⑤ ITEM 407 - TACK COAT
- ⑥ ITEM 204 - SUBGRADE COMPACTION
- ⑦ ITEM 659 - SEEDING AND MULCHING
- ⑧ ITEM 605 - AGGREGATE DRAINS
- ⑨ ITEM 254 - PAVEMENT PLANING, (ASPHALT CONCRETE) (SEE NOTE "A")
- ⑩ ITEM 441 - ASPHALT CONCRETE INTERMEDIATE COURSE, TYPE 1, (449) (THICKNESS VARIES)
- Ⓐ 15± ASPHALT

APPLIES TO PAVEMENT SLOPE OF 0.06 OR LESS

HIGH SIDE SHOULDER

HOL-39754-11.170.16, TUS-93-10.80

MODEL: Sheet PAPER SIZE: 17x11 (in.) DATE: 7/14/2022 TIME: 1:02:28 PM USER: JPerchinske P:\Transportation\Worksets\111666_HOL_39-1118\400-Engineering\Roadway\Sheets\111666_TUS-93-1118_GY301.dgn

TYPICAL SECTIONS - S.R. 93

DESIGN AGENCY

 www.bggroup.com
 5910 WILCOX PLACE, SUITE C
 DUBLIN, OHIO 43016

DESIGNER
JEP

REVIEWER
RG 7-14-22

PROJECT ID
111666

SHEET TOTAL
6 93

SEE SHEET 6 FOR LEGEND.

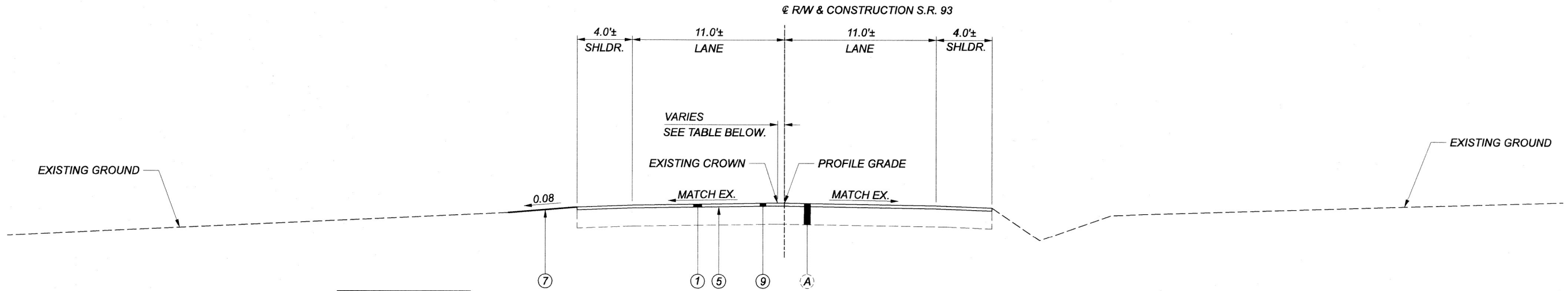

EX. CROWN LOCATION	
LT OFFSET	STATION
0.0'	111+50.00
0.1'	111+75.00
0.3'	112+00.00
0.4'	112+25.00
0.5'	112+50.00

RESURFACING SECTION - S.R. 93
STA. 112+25.00 TO STA. 112+50.00

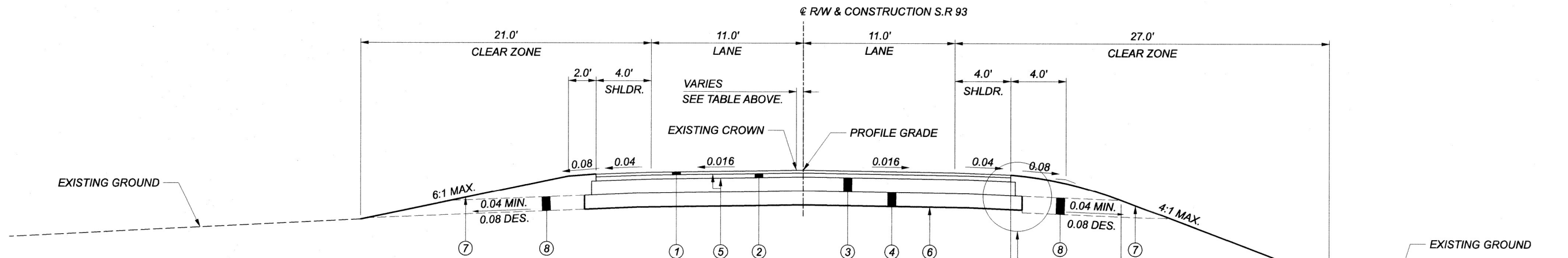

NORMAL SECTION - S.R. 93
**STA. 111+65.28 TO STA. 112+25.00

** = FOR CROSS SLOPE TRANSITIONS BETWEEN STA. 111+65.03 RT AND STA. 112+25.00 RT, SEE INTERSECTION DETAIL ON SHEET 54

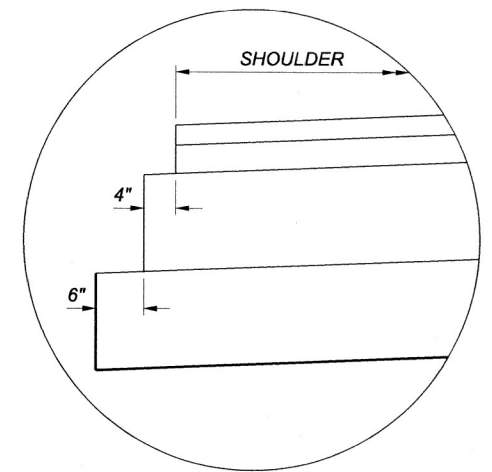

BASE AND SUBBASE STEP DETAIL

HOL-39/754-11.17/0.16, TUS-93-10.80

MODEL: Sheet PAPER SIZE: 17x11 (in.) DATE: 7/14/2022 TIME: 1:02:29 PM USER: JPerchinske
P:\Transportation\WorkSets\111666_HOL-39-1118\400-Engineering\Roadway\Sheets\111666_TUS-93-10.80.dgn

TYPICAL SECTIONS - S.R. 93

DESIGN AGENCY	
<small>5910 WILCOX PLACE, SUITE C DUBLIN, OHIO 43016</small>	
DESIGNER	JEP
REVIEWER	RG
PROJECT ID	111666
SHEET	TOTAL
7	93

ITEM 605 - AGGREGATE DRAINS

AGGREGATE DRAINS SHALL BE PLACED AT 50 FOOT INTERVALS ON EACH SIDE OF NORMAL CROWNED SECTIONS, STAGGERED SO THAT EACH DRAIN IS 25 FEET FROM THE ADJACENT DRAIN ON THE OPPOSITE SIDE, AND AT 25 FOOT INTERVALS ON THE LOW SIDE ONLY OF SUPERELEVATED SECTIONS. AN AGGREGATE DRAIN SHALL BE PLACED AT THE LOW POINT OF EACH SAG VERTICAL CURVE.

HOL-39-11.17					
89+00	LT	4	91+50	RT	13
89+25	LT	6	91+75	LT	12
89+50	LT	10	92+00	RT	13
89+75	LT	10	92+25	LT	13
90+00	LT	10	92+50	RT	13
90+25	LT	10	92+75	LT	13
90+50	LT	10	93+00	RT	9
90+75	LT	10	93+25	LT	11
91+00	LT	10	93+50	RT	6
91+25	LT	10	SUBTOTALS		192
HOL-754-0.16					
202+75	LT	5	204+75	LT	23
203+00	RT	8	205+00	LT	30
203+25	LT	15	205+25	LT	24
203+50	RT	8	205+50	LT	18
203+75	LT	15	206+50	RT	16
204+00	RT	9	206+75	RT	16
204+25	LT	15	207+00	RT	16
204+50	RT	9	SUBTOTALS		222
TUS-93-10.80					
110+25	LT	12	111+25	RT	10
110+50	RT	12	111+50	RT	10
111+00	LT	27	112+25	RT	3
SUBTOTALS					74

THE FOLLOWING QUANTITY IS PROVIDED IN THE GENERAL SUMMARY TO ADDRESS LOCATIONS FOR AGGREGATE DRAINS:

605, AGGREGATE DRAINS 488 FT

ARMORED SLOPE - S.R. 754

THE FOLLOWING ESTIMATED QUANTITIES ARE PROVIDED FOR USE FOR THE ARMORED SLOPE ALONG THE RIGHT SIDE OF S.R. 754 FROM STA. 202+25 TO STA. 204+53. SEE THE SLOPE DETAIL ON SHEET 4 FOR THE REQUIRED AGGREGATES AND THICKNESSES.

ITEM 203 - GRANULAR EMBANKMENT 112 CU. YD.

ITEM 304 - AGGREGATE BASE 130 CU. YD.

ITEM 601 - ROCK CHANNEL PROTECTION, TYPE B WITH FILTER 313 CU. YD.

ITEM 601 - ROCK CHANNEL PROTECTION, TYPE C WITH FILTER 59 CU. YD.

CENTERLINE REFERENCE - GROUND COORDINATES					
STATION	OFFSET	STREET	NORTHING	EASTING	DESCRIPTION
HOL-39-11.17					
83+14.58	0.00	€ S.R. 39	332035.6890	2098520.4505	POT
86+34.29	0.00	€ S.R. 39	331978.7461	2098835.0498	P.C.
88+45.64	8.84' RT	€ S.R. 39	331941.1031	2099043.0205	P.I.
90+56.01	0.00	€ S.R. 39	331938.5866	2099254.3555	P.T.
101+01.56	0.00	€ S.R. 39	331926.1374	2100299.9398	POT
HOL-754-0.16					
200+00.00	0.00	€ S.R. 754	333206.0256	2101596.4061	POT
208+15.73	0.00	€ S.R. 754	332394.2120	2101516.5687	P.C.
210+03.44	1.54' LT	€ S.R. 754	332207.4019	2101498.1969	P.I.
211+91.12	0.00	€ S.R. 754	332021.2938	2101473.7164	P.T.
214+04.93	0.00	€ S.R. 754	331809.3098	2101445.8322	POT
TUS-93-10.80					
106+98.78	0.00	€ S.R. 93	344876.5808	2221357.9306	P.C.C.
108+58.17	30.59' RT	€ S.R. 93	345003.6858	2221454.1054	P.I.
110+02.13	0.00	€ S.R. 93	345162.1016	2221436.5068	P.T.
111+97.00	0.00	€ S.R. 93	345355.7773	2221414.9912	P.I.
114+24.87	0.00	€ S.R. 93	345582.0598	2221388.1587	P.C.
116+42.45	27.41' RT	€ S.R. 93	345798.1296	2221362.5372	P.I.
118+50.89	0.00	€ S.R. 93	345999.9348	2221443.8840	P.T.
AGGREGATE DRAINS					
10+00.00	0.00	€ T.R. 436	345351.6556	2221415.4491	P.O.T.
10+79.82	0.00	€ T.R. 436	345351.9904	2221495.2640	P.O.T.

GENERAL NOTES

HOL-39/754-11.17/0.16, TUS-93-10.80

MODEL: Sheet PAPER: 17x11 (in.) DATE: 7/14/2022 TIME: 1:02:40 PM USER: JPerchinske P:\Transportation\Worksets\11666_HOL_39-11\11666-Engineering\Roadway\Sheets\11666_HOL_39-11B_GN001.dgn

DESIGN AGENCY

 www.bgggroup.com
 5910 WILCOX PLACE, SUITE C
 DUBLIN, OHIO 43016

DESIGNER
JEP

REVIEWER
RG 7-14-22

PROJECT ID
11666

SHEET TOTAL
9 **93**

HOL-39/754-11.1770.16, TUS-93-10.80

MODEL: Sheet PAPER SIZE: 17x11 (in.) DATE: 7/14/2022 TIME: 1:02:42 PM USER: JPerchinske P:\Transportation\Work\93-1118\400-Engineering\MOT\Sheets\111866_HOL-39-1118_MN001.dgn

MAINTENANCE OF TRAFFIC

ALL WORK ZONES SHALL BE MAINTAINED IN ACCORDANCE WITH THE OHIO DEPARTMENT OF TRANSPORTATION'S STANDARD CONSTRUCTION DRAWINGS, ITEM 614 IN C&MS, THE OHIO MANUAL OF UNIFORM TRAFFIC CONTROL DEVICES, AND THESE PLANS.

ITEM 614, MAINTAINING TRAFFIC

S.R. 754 WILL BE CLOSED AT SLM 0.16 AND S.R. 93 / T.R. 436 WILL BE CLOSED AT SLM 10.80 TO TRAFFIC FOR THE DURATION OF CONSTRUCTION. ROAD CLOSURES SHALL BE SIGNED PER SCD MT-101.60. DETOURS SHALL BE SIGNED AS SHOWN ON THE DETOUR PLAN SHEETS FOR EACH OF THE ABOVE LOCATIONS. CONCURRENT CLOSURES TO TRAFFIC FOR S.R. 754 AND S.R. 93 & T.R. 436 IS PERMITTED. CLOSURES SHALL ONLY BE PERMITTED DURING THE SUMMER SEASON WHEN SCHOOL IS NOT IN SESSION.

ALL NECESSARY ITEMS REQUIRED TO MAINTAIN TRAFFIC AS OUTLINED ABOVE SHALL BE INCLUDED IN THE LUMP SUM COST FOR ITEM 614 - MAINTAINING TRAFFIC.

A MINIMUM OF 1 LANE OF BI-DIRECTIONAL TRAFFIC ON S.R. 39 SHALL BE MAINTAINED AT ALL TIMES BY USE OF THE EXISTING PAVEMENT, THE COMPLETED PAVEMENT, ITEM 615 PAVEMENT FOR MAINTAINING TRAFFIC, AND TEMPORARY SURFACES USING ITEMS 410 AND 614.

A MINIMUM OF ONE LANE OF TRAFFIC IN EACH DIRECTION SHALL BE MAINTAINED AT ALL TIMES, EXCEPT FOR A PERIOD NOT TO EXCEED 14 CONSECUTIVE CALENDAR DAYS PER LOCATION, WHEN THROUGH TRAFFIC MAY BE DETOURED AS SHOWN ON SHEETS 15 AND 16. A DISINCENTIVE SHALL BE ASSESSED IN THE AMOUNT OF \$1585 FOR S.R. 754 AND \$5584 FOR S.R. 93 PER DAY FOR EACH CALENDAR DAY THE ROADWAY REMAINS CLOSED TO TRAFFIC BEYOND THE SPECIFIED LIMIT.

LENGTH AND DURATION OF LANE CLOSURES AND RESTRICTIONS SHALL BE AT THE APPROVAL OF THE ENGINEER. IT IS THE INTENT TO MINIMIZE THE IMPACT TO THE TRAVELING PUBLIC. LANE CLOSURES OR RESTRICTIONS OVER SEGMENTS OF THE PROJECT IN WHICH NO WORK IS ANTICIPATED WITHIN A REASONABLE TIME FRAME, AS DETERMINED BY THE ENGINEER, SHALL NOT BE PERMITTED. THE LEVEL OF UTILIZATION OF MAINTENANCE OF TRAFFIC DEVICES SHALL BE COMMENSURATE WITH THE WORK IN PROGRESS.

BEFORE THE WORK BEGINS, THE CONTRACTOR SHALL SUBMIT TO THE ENGINEER THE NAME(S) AND TELEPHONE NUMBER(S) OF A PERSON OR PERSONS WHO CAN BE CONTACTED TWENTY-FOUR (24) HOURS PER DAY BY THE OHIO DEPARTMENT OF TRANSPORTATION AND ALL INTERESTED POLICE AGENCIES. THIS PERSON OR PERSONS SHALL BE RESPONSIBLE FOR PLACING OR REPLACING NECESSARY TRAFFIC CONTROL DEVICES IN ACCORDANCE WITH THE OHIO MANUAL OF UNIFORM TRAFFIC CONTROL DEVICES.

NOTICE OF CLOSURE SIGNS (W20-H13) SHALL BE ERRECTED BY THE CONTRACTOR PRIOR TO THE SCHEDULED ROAD OR RAMP CLOSURE IN ACCORDANCE WITH THE NOTICE OF CLOSURE TIME TABLE BELOW.

ITEM	DURATION OF CLOSURE	SIGN DISPLAYED TO PUBLIC
	≥ 2 WEEKS	14 CALENDAR DAYS PRIOR TO CLOSURE
ROAD CLOSURES	> 12 HOURS & < 2 WEEKS	7 CALENDAR DAYS PRIOR TO CLOSURE
	≤ 12 HOURS	2 BUSINESS DAYS PRIOR TO CLOSURE

THE SIGNS SHALL BE ERRECTED ON THE RIGHT-HAND SIDE OF THE ROAD FACING TRAFFIC. THEY SHALL BE PLACED SO AS NOT TO INTERFERE WITH THE VISIBILITY OF ANY OTHER TRAFFIC CONTROL SIGNS. ON ROADWAYS, THEY SHOULD BE ERRECTED AT OR NEAR THE POINT OF CLOSURE.

THE SIGN SHALL DISPLAY THE DATE OF THE CLOSURE IN MMM-DD FORMAT AND THE NUMBER OF DAYS OF THE CLOSURE. THE LAST LINE OF THE W20-H13 SIGN LISTS A PHONE NUMBER WHICH A MOTORIST MAY CALL FOR ADDITIONAL INFORMATION. THIS IS TO BE A SPECIFIC OFFICE WITHIN THE DISTRICT RATHER THAN THE GENERAL SWITCHBOARD NUMBER.

SR 754 WILL BE CLOSED "MMM-DD" FOR 14 DAYS
INFO: 1-330-339-6633

W20-H13-60

SR 93 WILL BE CLOSED "MMM-DD" FOR 14 DAYS
INFO: 1-330-339-6633

W20-H13-60

ITEM 614, MAINTAINING TRAFFIC (CONTINUED)

THE CONTRACTOR SHALL PROVIDE, ERECT AND MAINTAIN STANDARD 48 X 30 INCH ROAD CLOSED SIGNS, SIGN SUPPORTS, BARRICADES AND LIGHTS, AS DETAILED IN SCD MT-101.60 AT THE FOLLOWING LOCATIONS DURING PERIODS IN WHICH THE AFFECTED ROADS ARE CLOSED TO TRAFFIC:

AT THE LIMITS OF THE WORK AREA FOR S.R. 754 AT THE LIMITS OF THE WORK AREA FOR S.R. 93

THE CONTRACTOR SHALL PROVIDE, ERECT AND MAINTAIN SIGNS AND SIGN SUPPORTS, AS DETAILED IN THE OHIO MANUAL OF UNIFORM TRAFFIC CONTROL DEVICES, AND TYPE III BARRICADES OF THE TYPE AND LOCATION AS FOLLOWS:

S.R. 754 JUST NORTH OF S.R. 39 INTERSECTION
S.R. 754 JUST SOUTH OF C.R. 316 INTERSECTION

S.R. 93 JUST NORTH OF C.R. 98 INTERSECTION
S.R. 93 JUST SOUTH OF C.R. 97 INTERSECTION

ALL WORK AND TRAFFIC CONTROL DEVICES SHALL BE IN ACCORDANCE WITH C&MS 614 AND OTHER APPLICABLE PORTIONS OF THE SPECIFICATIONS, AS WELL AS THE OHIO MANUAL OF UNIFORM TRAFFIC CONTROL DEVICES. PAYMENT FOR ALL LABOR, EQUIPMENT AND MATERIALS SHALL BE INCLUDED IN THE LUMP SUM CONTRACT PRICE FOR ITEM 614, MAINTAINING TRAFFIC, UNLESS SEPARATELY ITEMIZED IN THE PLAN.

SEQUENCE OF CONSTRUCTION FOR S.R. 39
IT IS THE INTENT OF THE FOLLOWING SEQUENCE OF CONSTRUCTION TO PROVIDE A WORK AREA FOR THE CONTRACTOR WHILE ALSO MAINTAINING TRAFFIC IN THE MANNER WHICH IS SAFE FOR THE TRAVELING PUBLIC. ALL WORK ZONE OR PERMANENT PAVEMENT MARKINGS SHALL BE IN PLACE BEFORE ANY PAVEMENT IS OPEN TO TRAFFIC. CONTRACTOR SHALL ERECT ALL TRAFFIC CONTROL DEVICES AND ENSURE THEY ARE IN GOOD WORKING ORDER PRIOR TO COMMENCING CONSTRUCTION ACTIVITIES ON THE BRIDGE. PRIOR TO ERRECTING PORTABLE BARRIER, PAVEMENT FOR MAINTAINING TRAFFIC SHALL BE PLACED AS SHOWN, ON SHEET 13.

ALL WORK ZONE SIGNING AND STRIPING SHALL BE IN PLACE PRIOR TO ERRECTING BARRIER, AS WELL AS THE WORK ZONE TRAFFIC SIGNAL INSTALLATIONS.

CONSTRUCTION FOR THE S.R. 39 PROJECT AREA MAY BE CONCURRENT WITH THE CLOSURES OF S.R. 754 AND S.R. 39. CONTRACTOR SHALL CONSTRUCT THE PROJECT IN THE FOLLOWING PHASES IN ORDER TO MAINTAIN TRAFFIC ALONG S.R. 39:

PRE-PHASE
DURING PRE-PHASE, THE NORTHERN SHOULDER AT THE BEGINNING AND ENDING OF THE PROJECT WILL BE CLOSED AS PER SCD MT-95.45. CONSTRUCT ALL WORK ZONE PAVEMENT FROM STA. 88+23 TO STA. 93+82LT. INSTALL ALL WORK ZONE TRAFFIC SIGNALS AS SHOWN ON SHEET 13 TO BE USED DURING PHASES 1 AND 2. CONTRACTOR IS TO MAINTAIN TWO-WAY TRAFFIC USING THE EXISTING PAVEMENT AS WELL AS MAINTAIN ACCESS TO THE DRIVEWAYS DURING PRE-PHASE CONSTRUCTION.

PHASE 1
DURING PHASE 1, TRAFFIC WILL BE SHIFTED TO THE EXISTING PAVEMENT ON THE NORTH SIDE (WESTBOUND) OF S.R. 39 AND REDUCED TO A SIGNALIZED ONE LANE, TWO-WAY TRAFFIC TO ALLOW CONSTRUCTION TO BE PERFORMED ON THE SOUTH SIDE OF S.R. 39. THROUGHOUT THE WORK AREA, THE LANE SHALL BE 10.0' WITH 1.0' PORTABLE BARRIER OFFSET AND A 2.0' SHOULDER. THE CONTRACTOR SHALL INSTALL ALL PORTABLE BARRIER, SIGNS, AND PAVEMENT MARKINGS AS SHOWN ON SHEET 13. FOR THE CULVERT PART-WIDTH CONSTRUCTION DETAILS, SEE CULVERT PLANS. THE CONTRACTOR SHALL MAINTAIN ACCESS TO ALL DRIVES WITHIN THE PROJECT LIMITS AT ALL TIMES. WORK PERFORMED IN THIS PHASE INCLUDES: EASTERN GUARDRAIL AND HALF OF THE EXISTING 4'X4' CULVERT REMOVAL, EASTBOUND PROPOSED PAVEMENT (UP TO AND INCLUDING THE INTERMEDIATE COURSE), GRADING, AND CONSTRUCTION OF THE EASTERN PORTION OF THE PROPOSED 6'X4' BOX CULVERT. CONSTRUCT WORK ZONE PAVEMENT FROM STA. 87+50 TO STA. 95+46RT TO BE USED DURING PHASE 2.

SEQUENCE OF CONSTRUCTION FOR S.R. 39 (CONTINUED)

PHASE 2
DURING PHASE 2, TRAFFIC WILL BE SHIFTED TO THE NEWLY CONSTRUCTED PAVEMENT ON THE SOUTH SIDE (EASTBOUND) OF S.R. 39, UTILIZING A SIGNALIZED ONE LANE, TWO-WAY TRAFFIC TO ALLOW CONSTRUCTION TO BE PERFORMED ON THE NORTH SIDE OF S.R. 39. THROUGHOUT THE WORK AREA, THE LANE SHALL BE 11.0' WITH 1.0' PORTABLE BARRIER OFFSET AND A 2.0' SHOULDER. THE CONTRACTOR SHALL INSTALL ALL PORTABLE BARRIER, SIGNS, AND PAVEMENT MARKINGS AS SHOWN ON SHEET 14 FOR THE CULVERT PART-WIDTH CONSTRUCTION DETAILS. SEE CULVERT PLAN. THE CONTRACTOR SHALL MAINTAIN ACCESS TO ALL DRIVES WITHIN THE PROJECT LIMITS AT ALL TIMES. WORK PERFORMED IN THIS PHASE INCLUDES: WESTERN GUARDRAIL AND HALF OF THE EXISTING 4'X4' CULVERT REMOVAL, WESTBOUND PROPOSED PAVEMENT (UP TO AND INCLUDING THE INTERMEDIATE COURSE), GRADING, AND CONSTRUCTION OF THE WESTERN PORTION OF THE PROPOSED 6'X4' BOX CULVERT. PHASE 2 TRAFFIC CONTROL DEVICES SHALL REMAIN IN PLACE UNTIL ALL REMAINING CONSTRUCTION ITEMS ARE IN PLACE.

FOLLOWING COMPLETION OF THE PREVIOUSLY DESCRIBED ITEMS, THE CONTRACTOR SHALL REMOVE WORK ZONE TRAFFIC CONTROL DEVICES, USING FLAGGERS TO CONTROL TRAFFIC. ALL SHORT TERM TRAFFIC CONTROL OPERATIONS SHALL CONFORM TO THE CURRENT EDITION OF THE OHIO MANUAL OF UNIFORM TRAFFIC CONTROL DEVICES (OMUTCD) AND SCD MT-97.10.

PHASE 3
THE PROPOSED INTERMEDIATE COURSE PLACED IN PHASES 1 AND 2 SHALL BE OVERLAID WITH THE FINAL 1.25" SURFACE COURSE. MAINTAIN TRAFFIC USING FLAGGERS IN ACCORDANCE WITH SCD MT-97.10. PLACE THE FINAL PAVEMENT MARKINGS.

ITEM 614, MAINTAINING TRAFFIC (LANES OPEN DURING HOLIDAYS OR SPECIAL EVENTS)

NO WORK SHALL BE PERFORMED AND ALL EXISTING LANES SHALL BE OPEN TO TRAFFIC DURING THE FOLLOWING DESIGNATED HOLIDAYS OR EVENTS:

CHRISTMAS FOURTH OF JULY
NEW YEAR'S LABOR DAY
MEMORIAL DAY THANKSGIVING

THE PERIOD OF TIME THAT THE LANES ARE TO BE OPEN DEPENDS ON THE DAY OF THE WEEK ON WHICH THE HOLIDAY OR EVENT FALLS. THE FOLLOWING SCHEDULE SHALL BE USED TO DETERMINE THIS PERIOD:

DAY OF HOLIDAY OR EVENT	TIME ALL LANES MUST BE OPEN TO TRAFFIC
SUNDAY	12:00N FRIDAY THROUGH 6:00 AM MONDAY
MONDAY	12:00N FRIDAY THROUGH 6:00 AM TUESDAY
TUESDAY	12:00N MONDAY THROUGH 6:00 AM WEDNESDAY
WEDNESDAY	12:00N TUESDAY THROUGH 6:00 AM THURSDAY
THURSDAY	12:00N WEDNESDAY THROUGH 6:00 AM FRIDAY
THURSDAY (THANKSGIVING ONLY)	6:00 AM WEDNESDAY THROUGH 6:00 AM MONDAY
FRIDAY	12:00N THURSDAY THROUGH 6:00 AM MONDAY
SATURDAY	12:00N FRIDAY THROUGH 6:00 AM MONDAY

SHOULD THE CONTRACTOR FAIL TO MEET ANY OF THESE REQUIREMENTS, THE CONTRACTOR SHALL BE ASSESSED A DISINCENTIVE AS SHOWN IN THE TABLE BELOW.

LANE VALUE CONTRACT TABLE		
DESCRIPTION OF CRITICAL LANE TO BE MAINTAINED	TIME UNIT	DISINCENTIVE \$ PER TIME UNIT
S.R. 39	PER LANE/ PER MIN.	\$70
S.R. 754	PER LANE/ PER MIN.	\$25
S.R. 93	PER LANE/ PER MIN.	\$15

NOTIFICATION OF TRAFFIC RESTRICTIONS

THROUGHOUT THE DURATION OF THE PROJECT, THE CONTRACTOR SHALL NOTIFY THE PROJECT ENGINEER IN WRITING OF ALL TRAFFIC RESTRICTIONS AND UPCOMING MAINTENANCE OF TRAFFIC CHANGES. THE CONTRACTOR SHALL ENSURE THE WRITTEN NOTIFICATION IS SUBMITTED IN A TIMELY MANNER TO ALLOW THE PROJECT ENGINEER TO MEET THE REQUIRED TIME FRAMES SET FORTH IN THE TABLE BELOW TO INFORM THE SPECIAL HAULING PERMITS SECTION (HAULING.PERMITS@DOT.OHIO.GOV) AND THE DISTRICT PUBLIC INFORMATION OFFICE (PIO). THIS NOTIFICATION SHALL BE RECEIVED BY THE PROJECT ENGINEER PRIOR TO THE PHYSICAL SETUP OF ANY APPLICABLE SIGNS OR MESSAGE BOARDS.

INFORMATION SHOULD INCLUDE, BUT IS NOT LIMITED TO, ALL CONSTRUCTION ACTIVITIES THAT IMPACT OR INTERFERE WITH TRAFFIC AND SHALL LIST THE SPECIFIC LOCATION, TYPE OF WORK, ROAD STATUS, DATE AND TIME OF RESTRICTION, DURATION OF RESTRICTION, NUMBER OF LANES MAINTAINED, NUMBER OF LANES CLOSED, MINIMUM VERTICAL CLEARANCE, MINIMUM WIDTH OF DRIVABLE PAVEMENT, DETOUR ROUTES, IF APPLICABLE, AND ANY OTHER INFORMATION REQUESTED BY THE PROJECT ENGINEER.

ITEM ROAD CLOSURES	DURATION OF CLOSURE	NOTICE DUE TO PERMITS & PIO
	≥ 2 WEEKS	21 CALENDAR DAYS PRIOR TO CLOSURE
	> 12 HOURS & < 2 WEEKS	14 CALENDAR DAYS PRIOR TO CLOSURE
	≤ 12 HOURS	4 BUSINESS DAYS PRIOR TO CLOSURE
LANE CLOSURES & RESTRICTIONS	≥ 2 WEEKS	14 CALENDAR DAYS PRIOR TO CLOSURE
	< 2 WEEKS	5 BUSINESS DAYS PRIOR TO CLOSURE
START OF CONSTRUCTION & TRAFFIC PATTERN CHANGES	N/A	14 CALENDAR DAYS PRIOR TO IMPLEMENTATION

ANY UNFORESEEN CONDITIONS NOT SPECIFIED IN THE PLANS REQUIRING TRAFFIC RESTRICTIONS SHALL ALSO BE REPORTED TO THE PROJECT ENGINEER USING THE NOTIFICATIONS TIME TABLE.

DESIGNATED STATE AND LOCAL DETOUR ROUTE

IN ADDITION TO THE OFFICIAL, SIGNED DETOUR ROUTE, A LOCAL ROUTE HAS BEEN DETERMINED TO BE THE SECONDARY, UNSIGNED DETOUR ROUTE OR "DESIGNATED LOCAL DETOUR ROUTE." THIS ROUTE IS SHOWN ON SHEETS 15 AND 16. DURING THE TIME THAT TRAFFIC IS DETOURED, THE CONTRACTOR SHALL MAINTAIN THIS ROUTE IN A CONDITION WHICH IS REASONABLY SMOOTH AND FREE FROM HOLES, RUTS, RIDGES, BUMPS, DUST AND STANDING WATER. ONCE THE DETOUR IS REMOVED AND TRAFFIC RETURNED TO ITS NORMAL PATTERN, THE DESIGNATED LOCAL DETOUR ROUTE SHALL BE RESTORED TO A CONDITION THAT IS EQUIVALENT TO THAT WHICH EXISTED PRIOR TO ITS USE FOR THIS PURPOSE. ALL SUCH WORK SHALL BE PERFORMED WHEN AND AS DETERMINED BY THE ENGINEER.

DURING THE TIME THAT TRAFFIC IS DETOURED, THOSE ROUTES THAT ARE PART OF THE OFFICIAL STATE DETOUR ROUTE THROUGH MUNICIPAL CORPORATIONS, THE CONTRACTOR SHALL MAINTAIN THESE ROUTES IN A CONDITION WHICH IS REASONABLY SMOOTH AND FREE FROM HOLES, RUTS, RIDGES, BUMPS, DUST, AND STANDING WATER.

THE FOLLOWING ESTIMATED QUANTITIES ARE PROVIDED FOR USE AS DETERMINED BY THE ENGINEER TO MAINTAIN AND SUBSEQUENTLY RESTORE THE DESIGNATED STATE AND LOCAL DETOUR ROUTE.

ITEM 441, ASPHALT CONCRETE SURFACE COURSE, TYPE 1, (449), PG70-22M, AS PER PLAN 25 CU. YD.
ITEM 407, TACK COAT 50 GAL.
ITEM 614, ASPHALT CONCRETE FOR MAINTAINING TRAFFIC 50 CU. YD.
ITEM 617, COMPACTED AGGREGATE 25 CU. YD.
ITEM 642, CENTER LINE 0.10 MILE

DETOUR SIGNING

ALL WORK ZONE DEVICES REQUIRED SHALL BE FURNISHED, ERRECTED, MAINTAINED AND SUBSEQUENTLY REMOVED BY THE CONTRACTOR. SEE SHEETS 15 AND 16 FOR THE DETOUR PLAN. PAYMENT FOR ALL WORK ASSOCIATED WITH THE DETOUR SHALL BE INCLUDED UNDER THE LUMP SUM BID FOR:

ITEM 614, DETOUR SIGNING LUMP

MAINTENANCE OF TRAFFIC NOTES

DESIGN AGENCY

 www.bgroup.com
 5910 WILCOX PLACE, SUITE C
 DUBLIN, OHIO 43016
 DESIGNER: JEP
 REVIEWER: RG
 PROJECT ID: 111866
 SHEET: 10 TOTAL: 93

REF. NO.	SHEET NO.	STATION TO STATION	SIDE	614						615			622								
				WORK ZONE IMPACT ATTENUATOR, 24" WIDE HAZARDS, (BIDIRECTIONAL) EACH	BARRIER REFLECTOR, TYPE 1 (TWO WAY) EACH	OBJECT MARKER, TWO WAY EACH	WORK ZONE CENTER LINE, CLASS 1, 642 PAINT (DOUBLE, SOLID) MILE	WORK ZONE EDGE LINE, CLASS 1, 6" 740.06, TYPE 1 (WHITE) MILE	WORK ZONE STOP LINE, CLASS 1, 740.06, TYPE 1 FEET	PAVEMENT FOR MAINTAINING TRAFFIC, CLASS B SQ YD	PORTABLE BARRIER, UNANCHORED FEET	PORTABLE BARRIER, ANCHORED FEET									
PHASE 1																					
CL-1	13	81+00 - 86+00	CL							0.09											
CL-2	13	95+51 - 100+51	CL							0.09											
ELW-1	13	86+88 - 95+01	LT/RT																		
ELW-2	13	88+46 - 94+05	LT							0.15											
P-1	13	88+42 - 93+83	LT																		
PB-1	13	88+30 - 94+20	LT/RT	2	13	13							147	500	90						
SL-1	13	86+00	RT																		
SL-2	13	95+51	LT							11											
PHASE 2																					
ELW-1	14	86+55 - 95+28	LT/RT							0.17											
ELW-2	14	87+50 - 95+36	RT							0.15											
P-1	14	87+77 - 90+00	RT																		
P-2	14	92+40 - 95+25	RT																		
PB-1	14	88+11 - 94+20	LT/RT	2	13	13							85	540	70						
TOTALS CARRIED TO GENERAL SUMMARY				4	26	26	0.18	0.58	22	354	1040	160									

DESIGN AGENCY

 www.bgggroup.com
 5910 WILCOX PLACE, SUITE C
 DUBLIN, OHIO 43016

DESIGNER
 JEP

REVIEWER
 RG 7-14-22

PROJECT ID
 111666

SHEET TOTAL
 12 93

MOT SUBSUMMARY

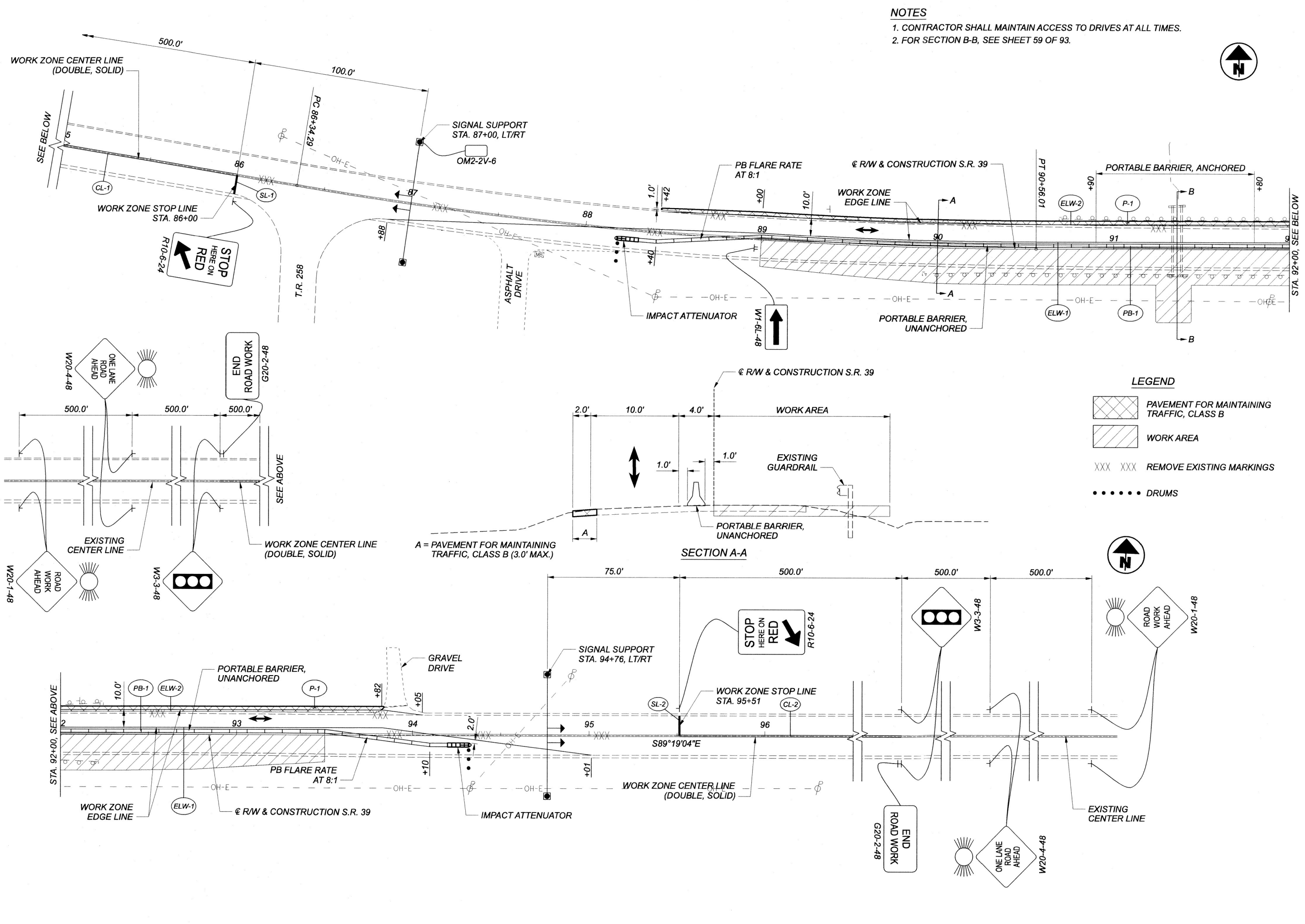

NOTES
 1. CONTRACTOR SHALL MAINTAIN ACCESS TO DRIVES AT ALL TIMES.
 2. FOR SECTION B-B, SEE SHEET 59 OF 93.

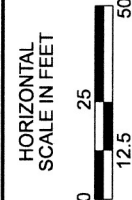

- LEGEND**
- PAVEMENT FOR MAINTAINING TRAFFIC, CLASS B
 - WORK AREA
 - XXX XXX REMOVE EXISTING MARKINGS
 - DRUMS

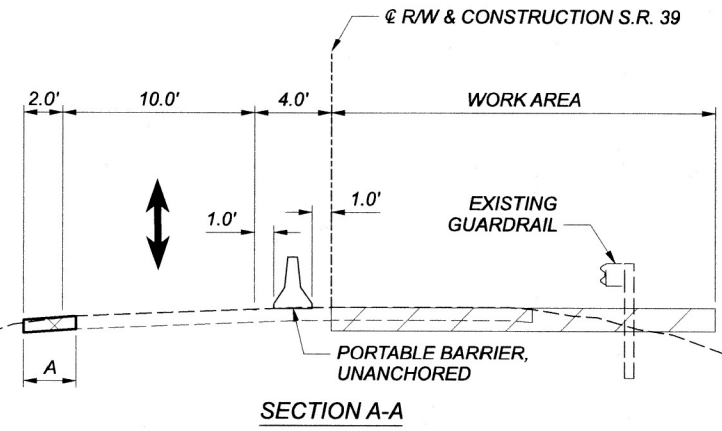

MAINTENANCE OF TRAFFIC - S.R. 39
PHASE 1

DESIGN AGENCY	
5910 WILCOX PLACE, SUITE C DUBLIN, OHIO 43016	
DESIGNER	JEP
REVIEWER	RG
PROJECT ID	111666
SHEET	TOTAL
13	93

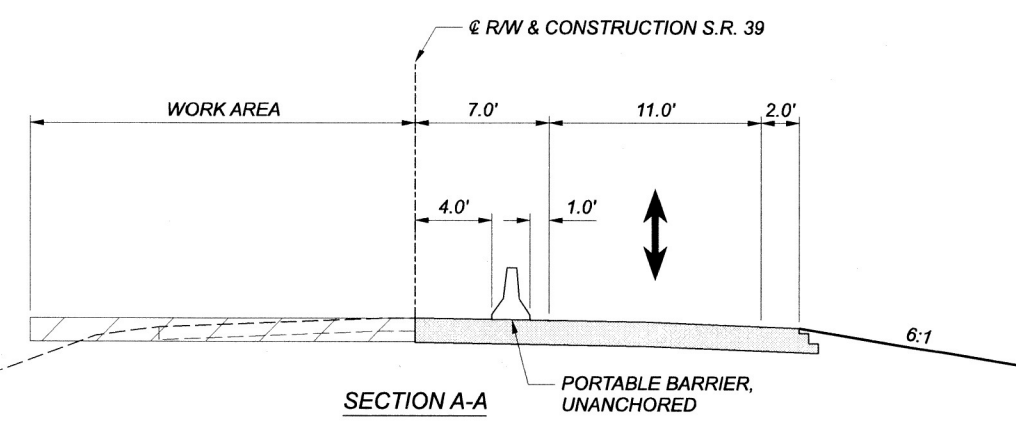
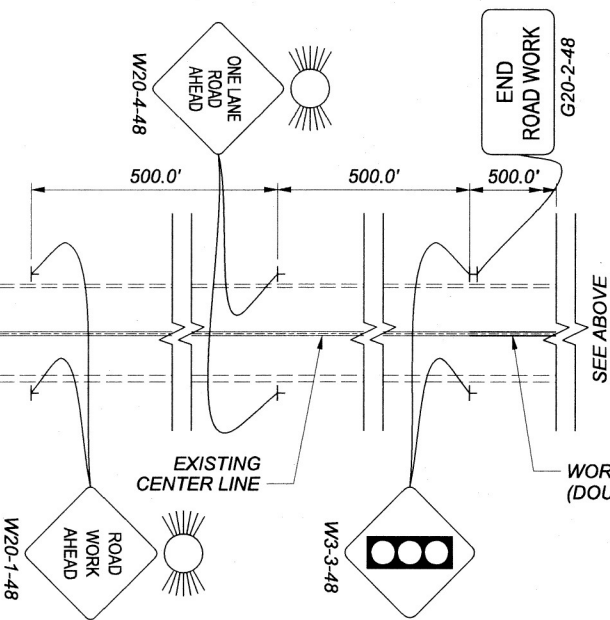
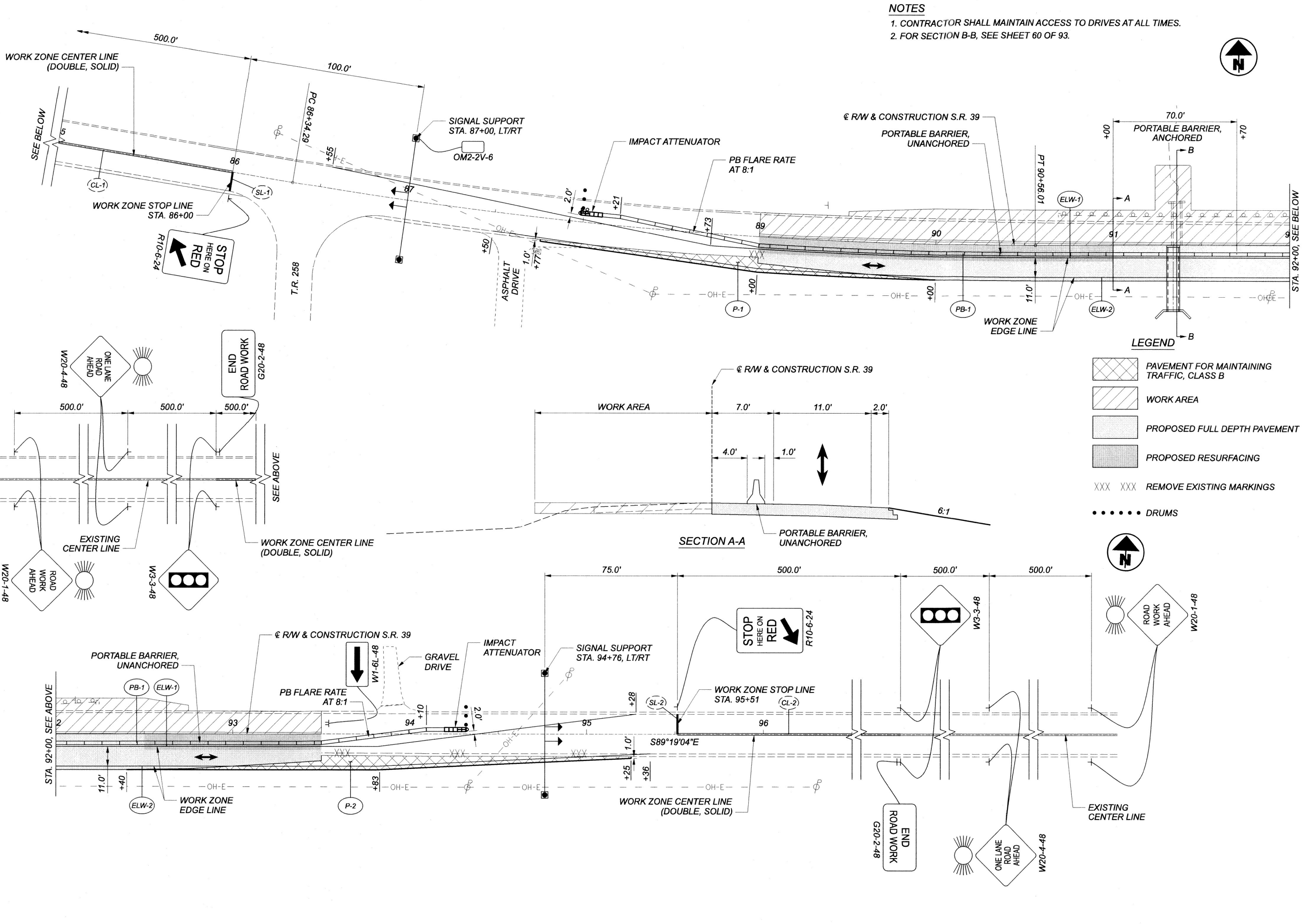

NOTES
 1. CONTRACTOR SHALL MAINTAIN ACCESS TO DRIVES AT ALL TIMES.
 2. FOR SECTION B-B, SEE SHEET 60 OF 93.

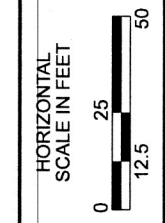

- LEGEND**
- PAVEMENT FOR MAINTAINING TRAFFIC, CLASS B
 - WORK AREA
 - PROPOSED FULL DEPTH PAVEMENT
 - PROPOSED RESURFACING
 - XXX XXX REMOVE EXISTING MARKINGS
 - DRUMS



DESIGN AGENCY	
DESIGNER	
JEP	
REVIEWER	
RG 6-8-22	
PROJECT ID	
111666	
SHEET	TOTAL
14	93

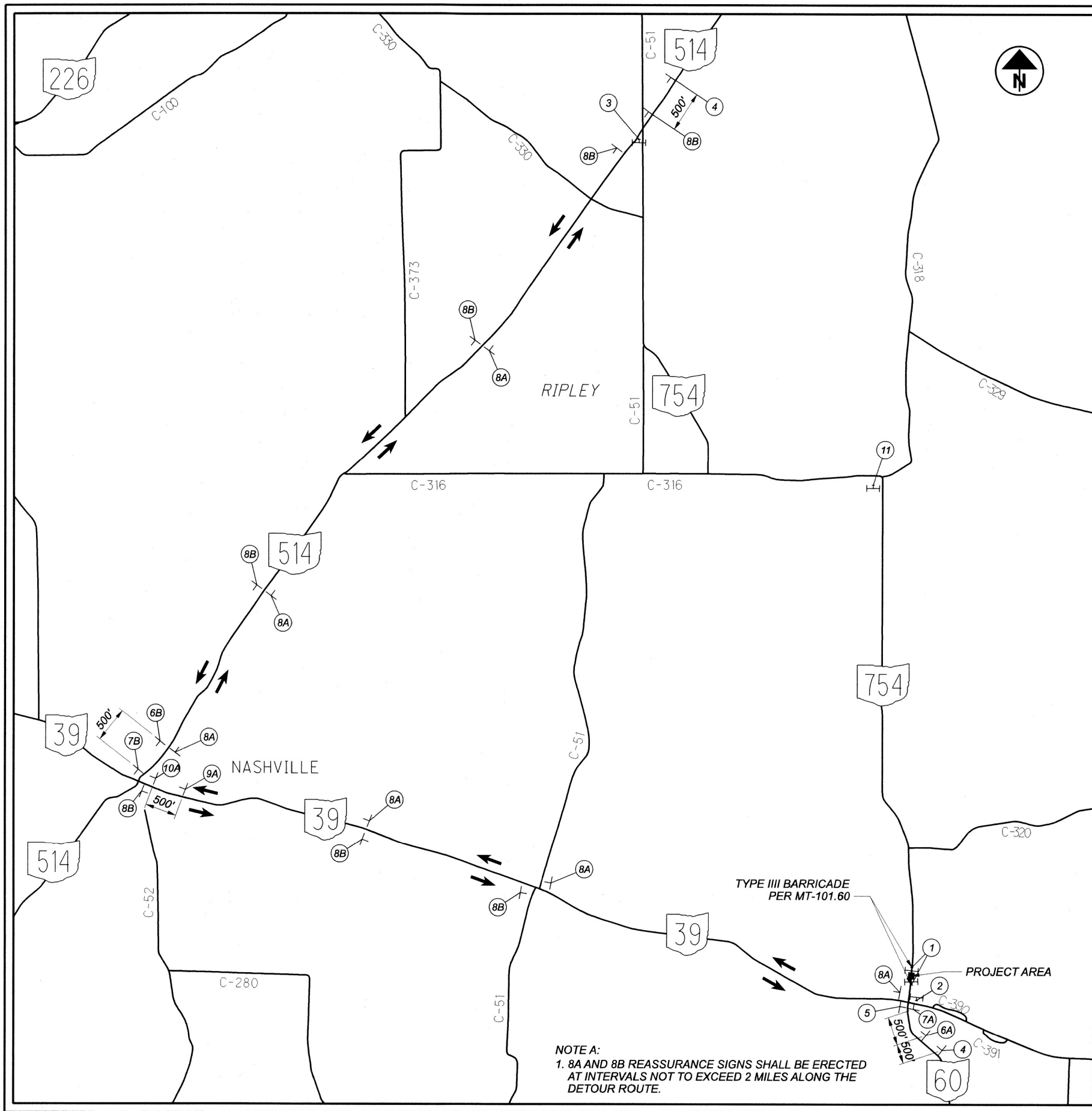

NOTE A:
 1. 8A AND 8B REASSURANCE SIGNS SHALL BE ERRECTED AT INTERVALS NOT TO EXCEED 2 MILES ALONG THE DETOUR ROUTE.

TYPE III BARRICADE PER MT-101.60

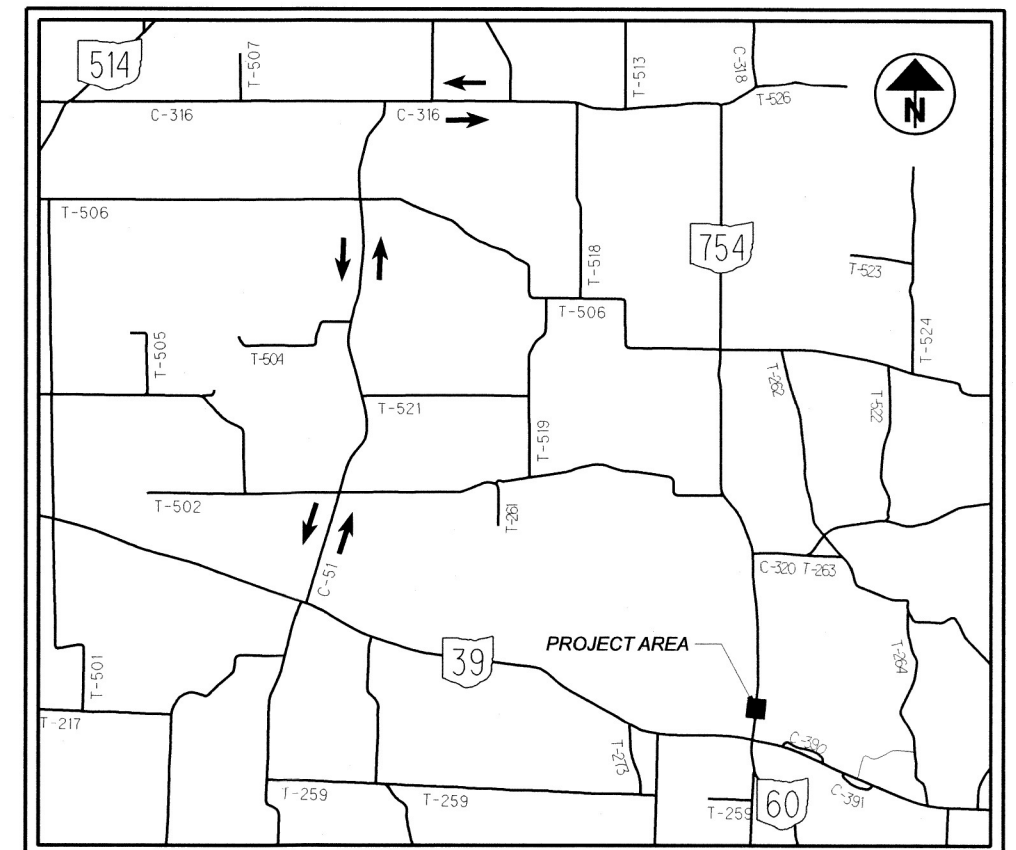
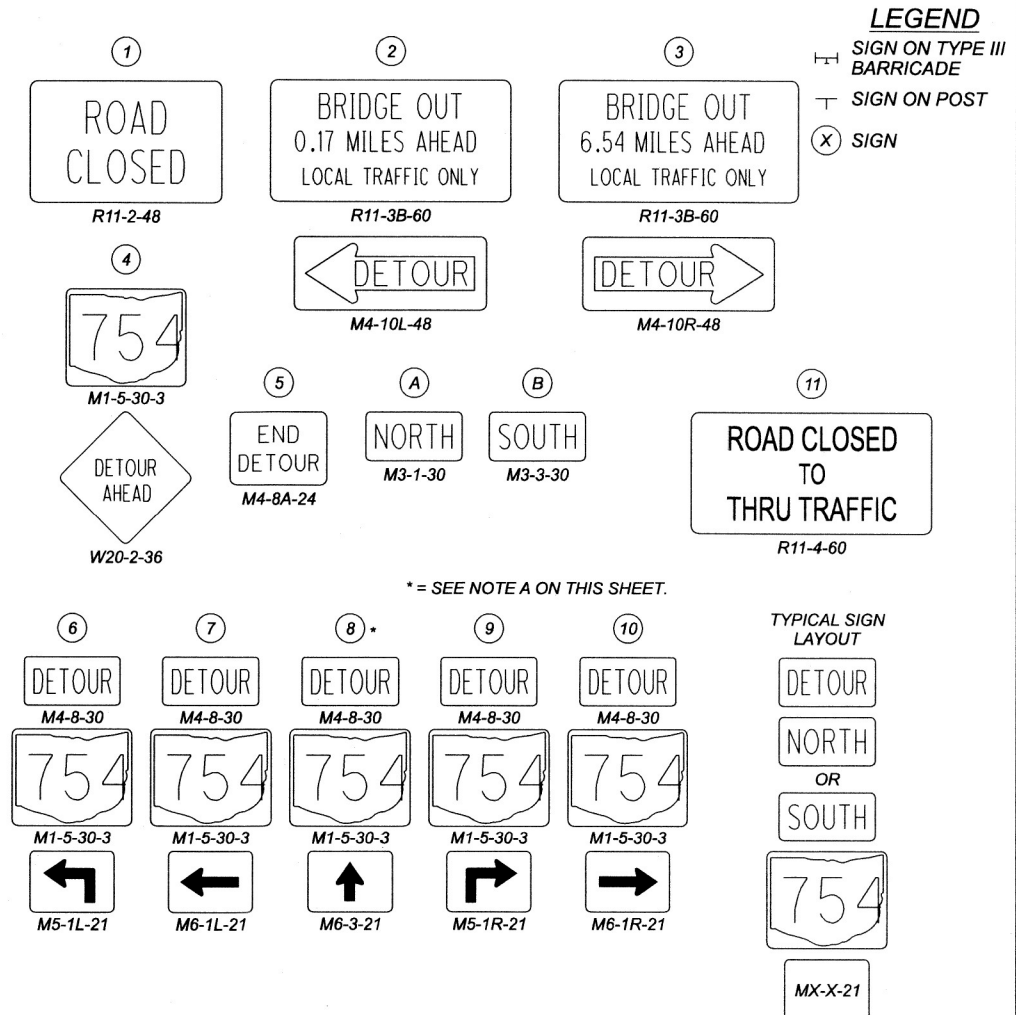

LOCAL DETOUR

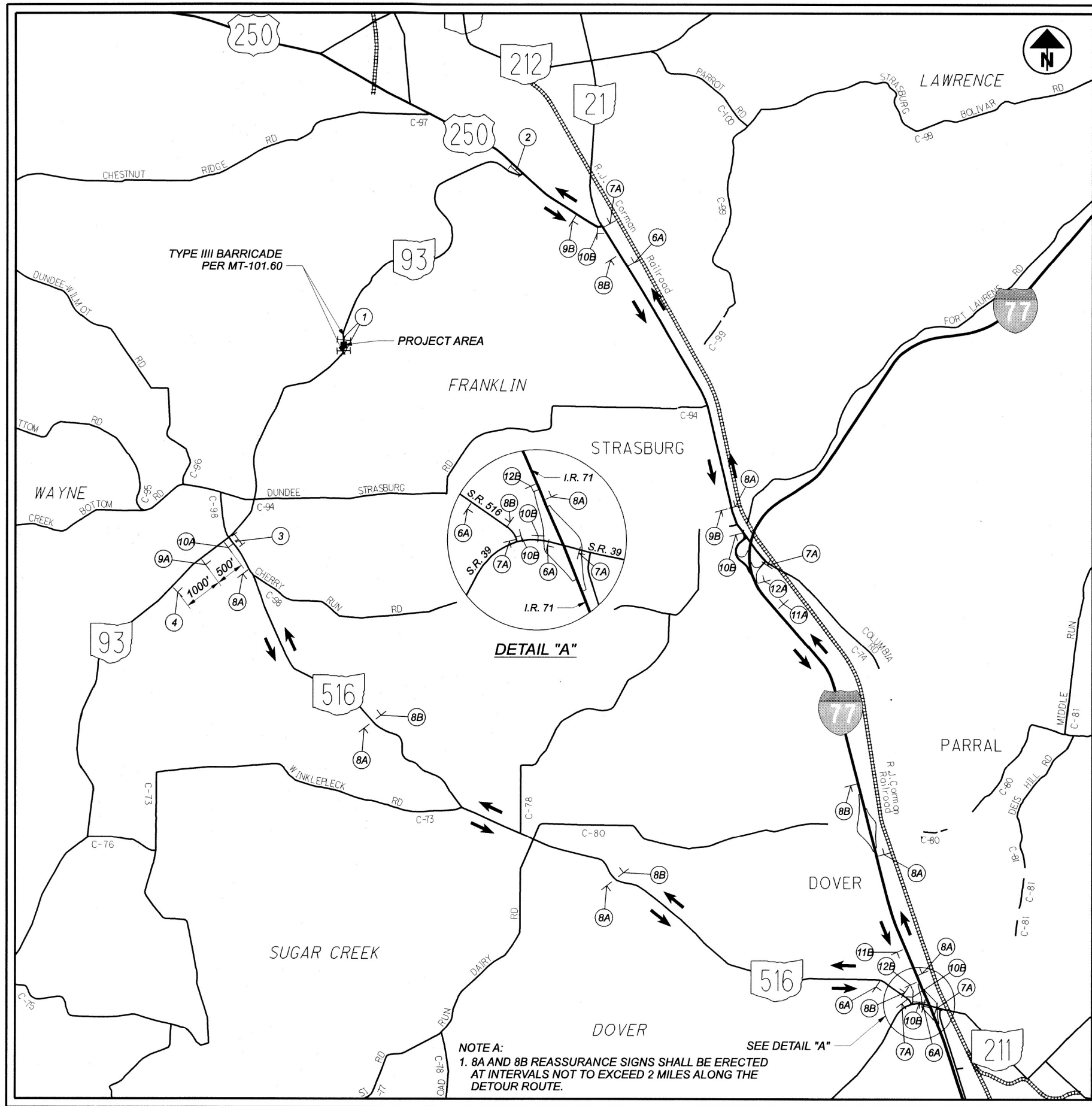

NOTE A:
 1. 8A AND 8B REASSURANCE SIGNS SHALL BE ERRECTED AT INTERVALS NOT TO EXCEED 2 MILES ALONG THE DETOUR ROUTE.

SEE DETAIL "A"

STATE DETOUR

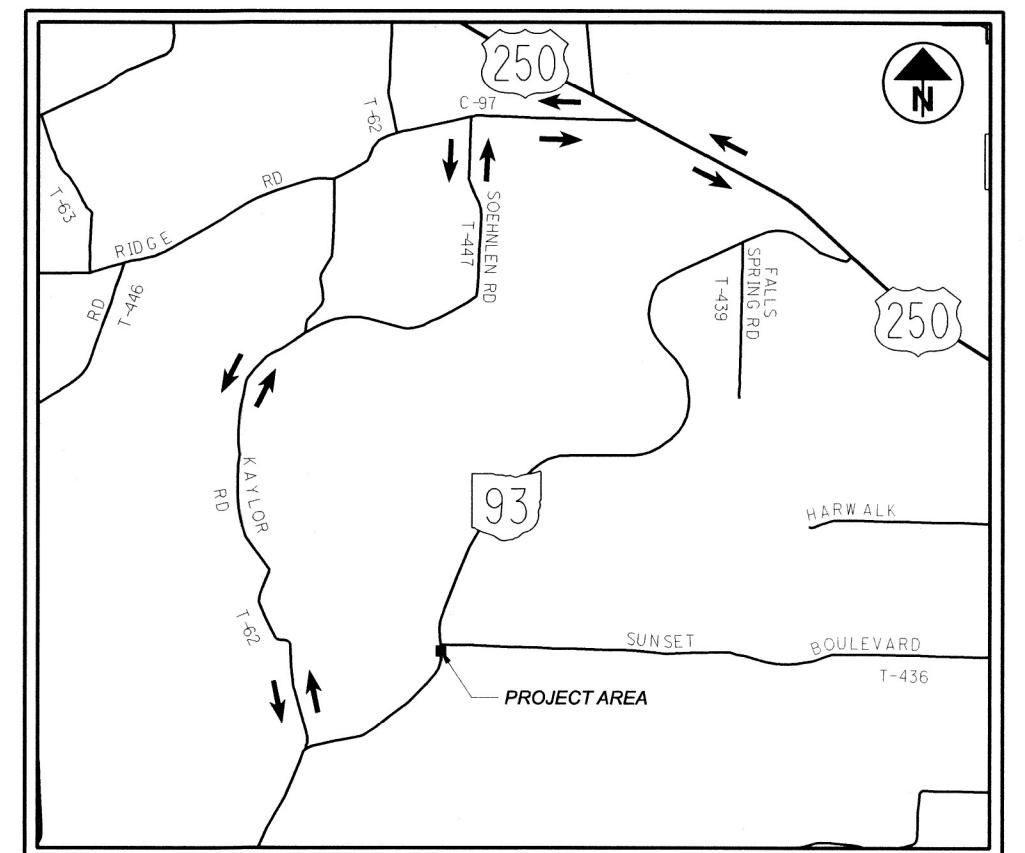

LOCAL DETOUR

LEGEND
 SIGN ON TYPE III BARRICADE
 SIGN ON POST
 SIGN

TYPICAL SIGN LAYOUT
 DETOUR
 NORTH OR SOUTH
 93
 MX-X-21

1 ROAD CLOSED R11-2-48
 2 BRIDGE OUT 2.82 MILES AHEAD LOCAL TRAFFIC ONLY R11-3B-60
 3 BRIDGE OUT 2.09 MILES AHEAD LOCAL TRAFFIC ONLY R11-3B-60
 4 DETOUR AHEAD W20-2-36
 5 END DETOUR M4-8A-24
 6 DETOUR M4-8-30
 7 DETOUR M4-8-30
 8 DETOUR M4-8-30
 9 DETOUR M4-8-30
 10 DETOUR M4-8-30
 11 DETOUR M4-8-30
 12 DETOUR M4-8-30

A NORTH M3-1-30
 B SOUTH M3-3-30

* = SEE NOTE A ON THIS SHEET.

M1-5-30-3
 M5-1L-21
 M6-1L-21
 M6-3-21
 M5-1R-21
 M6-1R-21
 M5-2-21
 M6-2-21

HOL-39/754-11.17/0.16, TUS-93-10.80

MODEL: Sheet PAPER SIZE: 17x11 (in.) DATE: 7/14/2022 TIME: 1:03:45 PM USER: JPerchinske
 P:\Transportation\Works\111666_HOL_39-1119\400-Engineering\Roadway\Sheets\111666_HOL_39-1118_GS001.dgn

SHEET NUM.													PART.	ITEM	ITEM	GRAND	UNIT	DESCRIPTION	SEE SHEET NO.	
8	9	10	23	33	45	31	40	51	56	79	80	81	OFFICE CALCS	01/STR/CV	EXT	TOTAL				
ROADWAY																				
LS			545	655	783									LS	201	11000	LS	CLEARING AND GRUBBING		
				104	53									1,983	202	23000	1,983	SY	PAVEMENT REMOVED	
			381	581	225									157	202	35100	157	FT	PIPE REMOVED, 24" AND UNDER	
				1										1,187	202	38000	1,187	FT	GUARDRAIL REMOVED	
														1	202	58100	1	EACH	CATCH BASIN REMOVED	
				369	160									529	202	75000	529	FT	FENCE REMOVED	
						636	646	222						1,504	203	10000	1,504	CY	EXCAVATION	
						1,183	753	255						2,191	203	20000	2,191	CY	EMBANKMENT	
	112													112	203	35000	112	CY	GRANULAR EMBANKMENT	
				137	81								3,174	3,392	204	10000	3,392	SY	SUBGRADE COMPACTION	
				375										375	606	15050	375	FT	GUARDRAIL, TYPE MGS	
				50										50	606	17360	50	FT	GUARDRAIL, TYPE MGS, LONG-SPAN	
				2										2	606	26150	2	EACH	ANCHOR ASSEMBLY, MGS TYPE E (NCHRP-350 OR MASH 2016)	
										1	1	4		6	623	40500	6	EACH	REFERENCE MONUMENT, TYPE A	
				2	2									4	SPECIAL	69050350	4	EACH	MAILBOX REMOVED AND RESET	
																			8	
EROSION CONTROL																				
	313													313	601	32100	313	CY	ROCK CHANNEL PROTECTION, TYPE B WITH FILTER	
			62	129	65									256	601	32104	256	CY	ROCK CHANNEL PROTECTION, TYPE B WITH GEOTEXTILE FABRIC	
	59													59	601	32200	59	CY	ROCK CHANNEL PROTECTION, TYPE C WITH FILTER	
6														6	659	00100	6	EACH	SOIL ANALYSIS TEST	
765			78											843	659	00300	843	CY	TOPSOIL	
6,892														6,892	659	10000	6,892	SY	SEEDING AND MULCHING	
345														345	659	14000	345	SY	REPAIR SEEDING AND MULCHING	
0.93														0.93	659	20000	0.93	TON	COMMERCIAL FERTILIZER	
1.42														1.42	659	31000	1.42	ACRE	LIME	
37														37	659	35000	37	MGAL	WATER	
			705											705	670	00500	705	SY	SLOPE EROSION PROTECTION	
														26,586	832	30000	26,586	EACH	EROSION CONTROL	
DRAINAGE																				
				1.25										1.25	602	20000	1.25	CY	CONCRETE MASONRY	
	488													488	605	31100	488	FT	AGGREGATE DRAINS	
50														50	611	01400	50	FT	6" CONDUIT, TYPE E	
50														50	611	01500	50	FT	6" CONDUIT, TYPE F	
					55									55	611	04900	55	FT	12" CONDUIT, TYPE D	
				5										5	611	07600	5	FT	18" CONDUIT, TYPE C	
				124										124	611	10400	124	FT	24" CONDUIT, TYPE B	
				1										1	611	98510	1	EACH	CATCH BASIN, NO. 2-3	
PAVEMENT																				
													1,916	1,916	254	01000	1,916	SY	PAVEMENT PLANING, ASPHALT CONCRETE	
	130			23	18									435	435	301	56000	435	CY	ASPHALT CONCRETE BASE, PG64-22, (449)
		50												453	624	304	20000	624	CY	AGGREGATE BASE
														552	602	407	10000	602	GAL	TACK COAT
														126	126	408	10001	126	GAL	PRIME COAT, AS PER PLAN
														70	70	411	10000	70	CY	STABILIZED CRUSHED AGGREGATE
		25		8										155	188	441	70101	188	CY	ASPHALT CONCRETE SURFACE COURSE, TYPE 1, (449), AS PER PLAN (PG70-22M)
														185	185	441	70300	185	CY	ASPHALT CONCRETE INTERMEDIATE COURSE, TYPE 2, (449)
																				8
TRAFFIC CONTROL																				
														30	621	00100	30	EACH	RPM	
														30	621	54000	30	EACH	RAISED PAVEMENT MARKER REMOVED	
														14	626	00110	14	EACH	BARRIER REFLECTOR, TYPE 2 (BIDIRECTIONAL)	
														30.5	630	02100	30.5	FT	GROUND MOUNTED SUPPORT, NO. 2 POST	
														121.6	630	03100	121.6	FT	GROUND MOUNTED SUPPORT, NO. 3 POST	
														7	630	08600	7	EACH	SIGN POST REFLECTOR	
														90	630	80100	90	SF	SIGN, FLAT SHEET	
														21	630	84900	21	EACH	REMOVAL OF GROUND MOUNTED SIGN AND DISPOSAL	
														2	630	85100	2	EACH	REMOVAL OF GROUND MOUNTED SIGN AND REERECTION	

GENERAL SUMMARY

DESIGN AGENCY

 www.bggroup.com
 5910 WILCOX PLACE, SUITE C
 DUBLIN, OHIO 43016

DESIGNER
 JEP

REVIEWER
 RG 7-14-22

PROJECT ID
 111666

SHEET TOTAL
 17 93

HOL-39/754-11.170.16, TUS-93-10.80

MODEL: Sheet PAPER/SIZE: 17X11 (in.) DATE: 7/14/2022 TIME: 1:03:46 PM USER: JPerchinske
 P:\Transportation\Worksets\111666_HOL_39-118\400-Engineering\Roadway\Sheets\111666_HOL_39-118_GG001.dgn

SHEET NUM.										PART.	ITEM	ITEM	GRAND	UNIT	DESCRIPTION	SEE SHEET NO.
10	11	12	56	58	66	73	01/STR/CV	EXT	TOTAL							
			13				13	630	86002	13	EACH	REMOVAL OF GROUND MOUNTED POST SUPPORT AND DISPOSAL				
0.1			0.49				0.49	646	10010	0.49	MILE	EDGE LINE, 6"				
			0.28				0.38	646	10200	0.38	MILE	CENTER LINE				
			54				54	646	10600	54	FT	TRANSVERSE/DIAGONAL LINE				
STRUCTURE 20 FOOT SPAN AND UNDER (HOL-00039-11.176)																
				LS			LS	202	11000	LS		STRUCTURE REMOVED				
				LS			LS	503	11101	LS		COFFERDAMS AND EXCAVATION BRACING, AS PER PLAN	58			
				59			59	503	21100	59	CY	UNCLASSIFIED EXCAVATION				
				3,447			3,447	509	10000	3,447	LB	EPOXY COATED REINFORCING STEEL				
				7			7	511	46010	7	CY	CLASS QC1 CONCRETE, RETAINING/WINGWALL NOT INCLUDING FOOTING				
				19			19	511	46510	19	CY	CLASS QC1 CONCRETE, FOOTING				
				1			1	511	46610	1	CY	CLASS QC1 CONCRETE, HEADWALL				
				36			36	512	10100	36	SY	SEALING OF CONCRETE SURFACES (EPOXY-URETHANE)				
				169			169	512	33000	169	SY	TYPE 2 WATERPROOFING				
				27			27	516	13600	27	SF	1" PREFORMED EXPANSION JOINT FILLER				
				6			6	518	21200	6	CY	POROUS BACKFILL WITH GEOTEXTILE FABRIC				
				78			78	611	94701	78	FT	6' X 4' CONDUIT, TYPE A, 706.05, AS PER PLAN, DESIGN COVER 4 FT	\$118_SN001			
				87			87	613	41200	87	CY	LOW STRENGTH MORTAR BACKFILL				
STRUCTURE 20 FOOT SPAN AND UNDER (HOL-00754-0.169) (SFN 3803246)																
				LS			LS	202	11000	LS		STRUCTURE REMOVED				
				LS			LS	503	11100	LS		COFFERDAMS AND EXCAVATION BRACING				
				98			98	503	21100	98	CY	UNCLASSIFIED EXCAVATION				
				6,381			6,381	509	10000	6,381	LB	EPOXY COATED REINFORCING STEEL				
				13			13	511	46010	13	CY	CLASS QC1 CONCRETE, RETAINING/WINGWALL NOT INCLUDING FOOTING				
				42			42	511	46510	42	CY	CLASS QC1 CONCRETE, FOOTING				
				2			2	511	46610	2	CY	CLASS QC1 CONCRETE, HEADWALL				
				65			65	512	10100	65	SY	SEALING OF CONCRETE SURFACES (EPOXY-URETHANE)				
				274			274	512	33000	274	SY	TYPE 2 WATERPROOFING				
				35			35	516	13600	35	SF	1" PREFORMED EXPANSION JOINT FILLER				
				10			10	518	21200	10	CY	POROUS BACKFILL WITH GEOTEXTILE FABRIC				
				77			77	611	96311	77	FT	14' X 5' CONDUIT, TYPE A, 706.05, AS PER PLAN, DESIGN COVER 2 FT	66			
				120			120	613	41200	120	CY	LOW STRENGTH MORTAR BACKFILL				
STRUCTURE 20 FOOT SPAN AND UNDER (TUS-00093-10.809)																
				LS			LS	202	11000	LS		STRUCTURE REMOVED				
				LS			LS	503	11100	LS		COFFERDAMS AND EXCAVATION BRACING				
				56			56	503	21104	56	CY	UNCLASSIFIED EXCAVATION, INCLUDING ROCK				
				3,508			3,508	509	10000	3,508	LB	EPOXY COATED REINFORCING STEEL				
				8			8	511	46010	8	CY	CLASS QC1 CONCRETE, RETAINING/WINGWALL NOT INCLUDING FOOTING				
				22			22	511	46510	22	CY	CLASS QC1 CONCRETE, FOOTING				
				1			1	511	46610	1	CY	CLASS QC1 CONCRETE, HEADWALL				
				42			42	512	10100	42	SY	SEALING OF CONCRETE SURFACES (EPOXY-URETHANE)				
				194			194	512	33000	194	SY	TYPE 2 WATERPROOFING				
				26			26	516	13600	26	SF	1" PREFORMED EXPANSION JOINT FILLER				
				8			8	518	21200	8	CY	POROUS BACKFILL WITH GEOTEXTILE FABRIC				
				74			74	611	94937	74	FT	9' X 4' CONDUIT, TYPE A, 706.05, AS PER PLAN, DESIGN COVER 1 FT	73			
				82			82	613	41200	82	CY	LOW STRENGTH MORTAR BACKFILL				
MAINTENANCE OF TRAFFIC																
	75						75	410	13000	75	CY	TRAFFIC COMPACTED SURFACE, TYPE C				
	16						16	614	11110	16	HOUR	LAW ENFORCEMENT OFFICER WITH PATROL CAR FOR ASSISTANCE				
	2						2	SPECIAL	61411300	2	EACH	WORK ZONE TRAFFIC SIGNAL	11			
	120						120	614	11630	120	FT	INCREASED BARRIER DELINEATION				
		4					4	614	12384	4	EACH	WORK ZONE IMPACT ATTENUATOR, 24" WIDE HAZARDS, (BIDIRECTIONAL)				
LS							LS	614	12420	LS		DETOUR SIGNING				
	2						2	614	12740	2	EACH	WORK ZONE LIGHTING SYSTEM				
50							50	614	13000	50	CY	ASPHALT CONCRETE FOR MAINTAINING TRAFFIC				
		26					26	614	13310	26	EACH	BARRIER REFLECTOR, TYPE 1 (TWO-WAY)				
	4						4	614	13312	4	EACH	BARRIER REFLECTOR, TYPE 2 (BI-DIRECTIONAL)				

GENERAL SUMMARY

DESIGN AGENCY

 www.bggroup.com
 8919 WILGOSH PLAGE, SUITE 6
 DUBLIN, OHIO 43016

DESIGNER
 JEP

REVIEWER
 RG 7-14-22

PROJECT ID
 111666

SHEET TOTAL
 18 93

HOL-39/754-11.170.16, TUS-93-10.80

MODEL: Sheet PAPERSIZE: 17x11 (in.) DATE: 7/14/2022 TIME: 1:03:47 PM USER: JPerchinske
P:\Transportation\WorkSets\111666_HOI_39-118M400-Engineering\Roadway\Sheets\111666_HOI_39-118_G0001.dgn

SHEET NUM.

PART.

ITEM

ITEM

GRAND

UNIT

DESCRIPTION

SEE SHEET NO.

10 11 12

01/STR/CV

EXT

TOTAL

4

0.3

26

0.18

0.58

22

354

30

614

13360

30

EACH

OBJECT MARKER, TWO WAY

0.48

614

21100

0.48

MILE

WORK ZONE CENTER LINE, CLASS I, 642 PAINT

0.58

614

22210

0.58

MILE

WORK ZONE EDGE LINE, CLASS I, 6", 740.06, TYPE I

22

614

26400

22

FT

WORK ZONE STOP LINE, CLASS I, 740.06, TYPE I

354

615

25000

354

SY

PAVEMENT FOR MAINTAINING TRAFFIC, CLASS B

25

11

11

616

10000

11

MGAL

WATER

25

617

10100

25

CY

COMPACTED AGGREGATE

1,040

1,040

622

41100

1,040

FT

PORTABLE BARRIER, UNANCHORED

160

160

622

41110

160

FT

PORTABLE BARRIER, ANCHORED

INCIDENTALS

LS

LS

614

11000

LS

MAINTAINING TRAFFIC

6

619

16010

6

MNTH

FIELD OFFICE, TYPE B

LS

623

10000

LS

CONSTRUCTION LAYOUT STAKES AND SURVEYING

LS

624

10000

LS

MOBILIZATION

GENERAL SUMMARY

DESIGN AGENCY

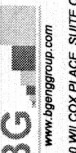

www.bgroup.com
8910 WILCOX PLACE, SUITE C
DUBLIN, OHIO 43016

DESIGNER

JEP

REVIEWER

RG 7-14-22

PROJECT ID

111666

SHEET TOTAL

19 | 93



PROJECT SITE PLAN - S.R. 39

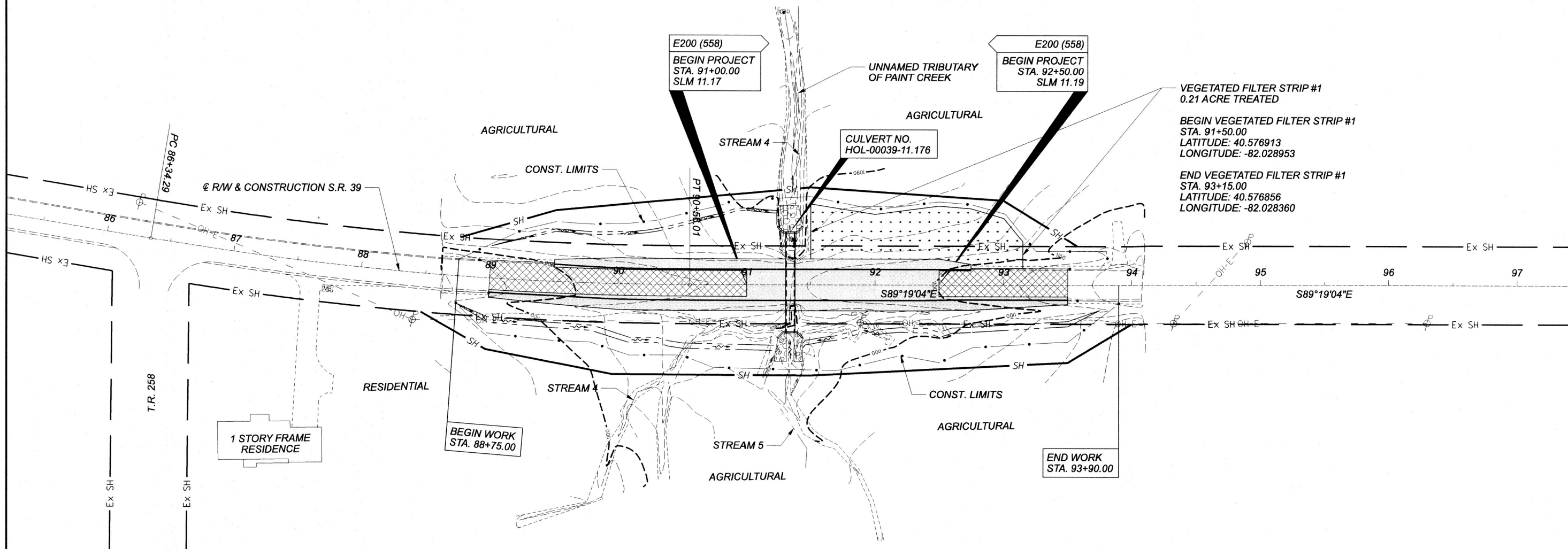

VEGETATED FILTER STRIP #1
0.21 ACRE TREATED

BEGIN VEGETATED FILTER STRIP #1
STA. 91+50.00
LATITUDE: 40.576913
LONGITUDE: -82.028953

END VEGETATED FILTER STRIP #1
STA. 93+15.00
LATITUDE: 40.576856
LONGITUDE: -82.028360

E200 (558)
BEGIN PROJECT
STA. 91+00.00
SLM 11.17

E200 (558)
BEGIN PROJECT
STA. 92+50.00
SLM 11.19

CULVERT NO.
HOL-00039-11.176

BEGIN WORK
STA. 88+75.00

END WORK
STA. 93+90.00

USGS QUADRANT GLENMONT,
MONROE TOWNSHIP, OHIO
DATED 2019
LATITUDE: 40° 34' 35"
LONGITUDE: 82° 01' 45"

PROJECT DATA	SITE HOL-39-11.17
TOTAL AREA (RIGHT-OF-WAY)	1.45 AC
PROJECT EARTH DISTURBED AREA	1.00 AC
ESTIMATED CONTRACTOR EARTH DISTURBED AREA	0.09 AC
NOTICE OF INTENT EARTH DISTURBED AREA	1.09 AC
IMPERVIOUS (PAVED) AREA FOR PRE-CONSTRUCTION SITE	0.26 AC
IMPERVIOUS (PAVED) AREA FOR POST CONSTRUCTION SITE	0.38 AC
RUNOFF COEFFICIENT FOR PRE-CONSTRUCTION SITE	0.60
RUNOFF COEFFICIENT FOR POST CONSTRUCTION SITE	0.65
IMMEDIATE RECEIVING WATERS	UNNAMED TRIBUTARY OF PAINT CREEK
SUBSEQUENT RECEIVING WATER	KILLBUCK CREEK
POST CONSTRUCTION BMP	VEGETATED FILTER STRIP
SOIL MAP HOLMES COUNTY, OHIO (OH075)	FhA, WsC2

BMP	STATION		AREA TREATED	LATITUDE / LONGITUDE	
	FROM	TO		BEGIN	END
VEGETATED FILTER STRIP #1	91+50	93+15	0.21 AC.	40.576913 -82.028953	40.576856 -82.028360
TOTAL TREATMENT			0.21 AC.		

TREATMENT REQUIRED 0.20 AC. < 0.21 AC.; OK

- ITEMS INCLUDED WITH VEGETATED FILTER STRIP:
- ITEM 659, TOPSOIL (ADD 4" TO THE GRASS PORTION OF THE SHOULDER AND FORESLOPE OF THE VEGETATED FILTER STRIP)
 - ITEM 670, SLOPE EROSION PROTECTION

- PROPOSED PAVEMENT
- RESURFACING
- VEGETATED FILTER STRIP
- ROCK CHANNEL PROTECTION, TYPE B WITH FILTER (2'-6" THICK, TYP.)

PROJECT DESCRIPTION
REPLACEMENT OF THREE EXISTING CULVERTS:
HOL-00039-11.176, HOL-00754-0.169, AND TUS-00093-10.809
INCLUDING MINOR APPROACH ROADWAY PAVEMENT REPLACEMENT.

HOL-39/754-11.170.16, TUS-93-10.80

MODEL: Sheet_PAPER: 17x11 (in.) DATE: 7/14/2022 TIME: 1:04:06 PM USER: JPerchinski P:\Transportation\Work\111666_HOL-39-1118\M00-Engineering\Drainage\Sheets\111666_HOL-39-1118_DE001.dgn

DESIGN AGENCY
 BG GROUP
 9910 MILCOX PLACE, SUITE C
 DUBLIN, OHIO 43016

DESIGNER
JEP

REVIEWER
RG 6-8-22

PROJECT ID
111666

SHEET TOTAL
20 93

CROSS REFERENCES	
SHEET NO.	DESCRIPTION
23	ESTIMATED QUANTITIES
24-31	CROSS SECTIONS
52	SUPERELEVATION TABLES
57-64	CULVERT DETAILS

BENCHMARK DATA	
BM#1	STA. 88+42.49 35.62' RT ELEV. 1105.97 ON UTILITY POLE
BM#2	STA. 94+32.18 30.12' RT ELEV. 1109.63 ON UTILITY POLE

CURVE 1 DATA
 P.I. = STA. 88+45.64
 $\Delta = 09^{\circ}34'38''$ LT
 $D_c = 02^{\circ}16'16''$
 $R = 2,522.89'$
 $T = 211.35'$
 $L = 421.72'$
 $E = 8.84'$
 P.C. STA. 86+34.29

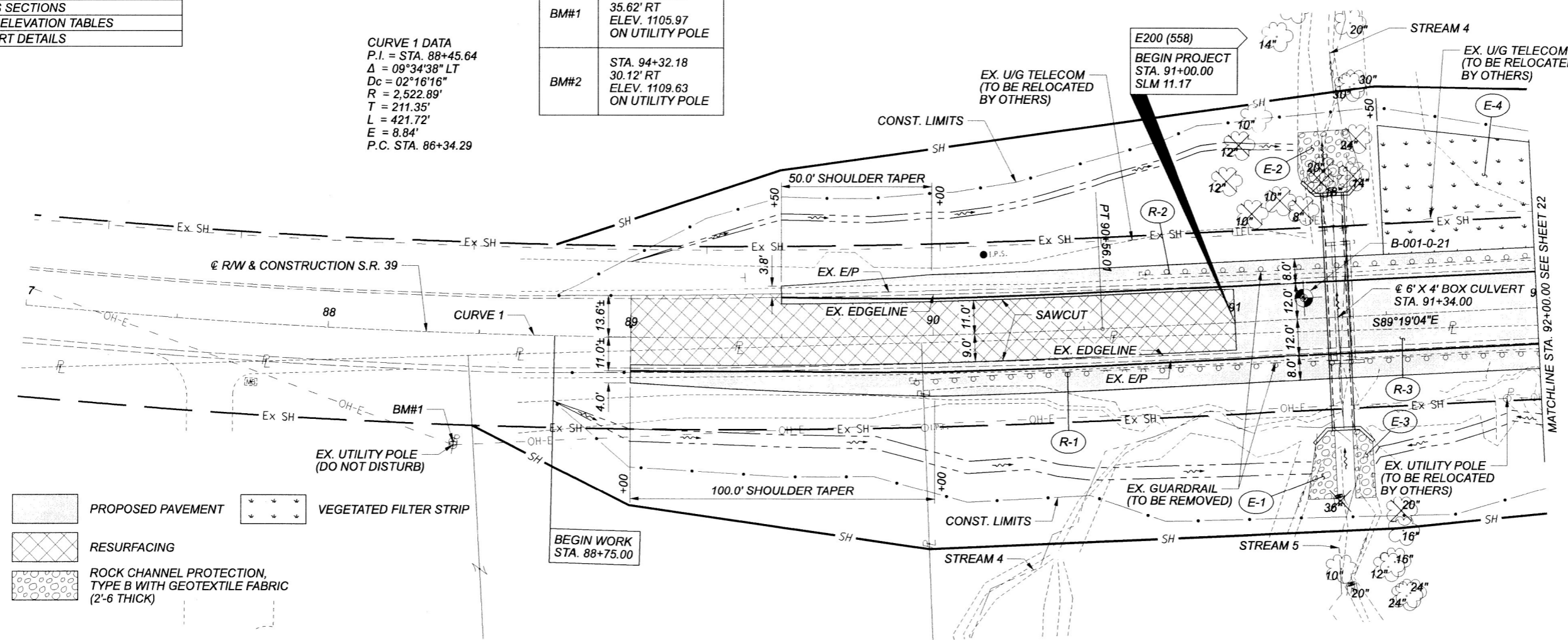

- PROPOSED PAVEMENT
- RESURFACING
- ROCK CHANNEL PROTECTION, TYPE B WITH GEOTEXTILE FABRIC (2'-6" THICK)
- VEGETATED FILTER STRIP

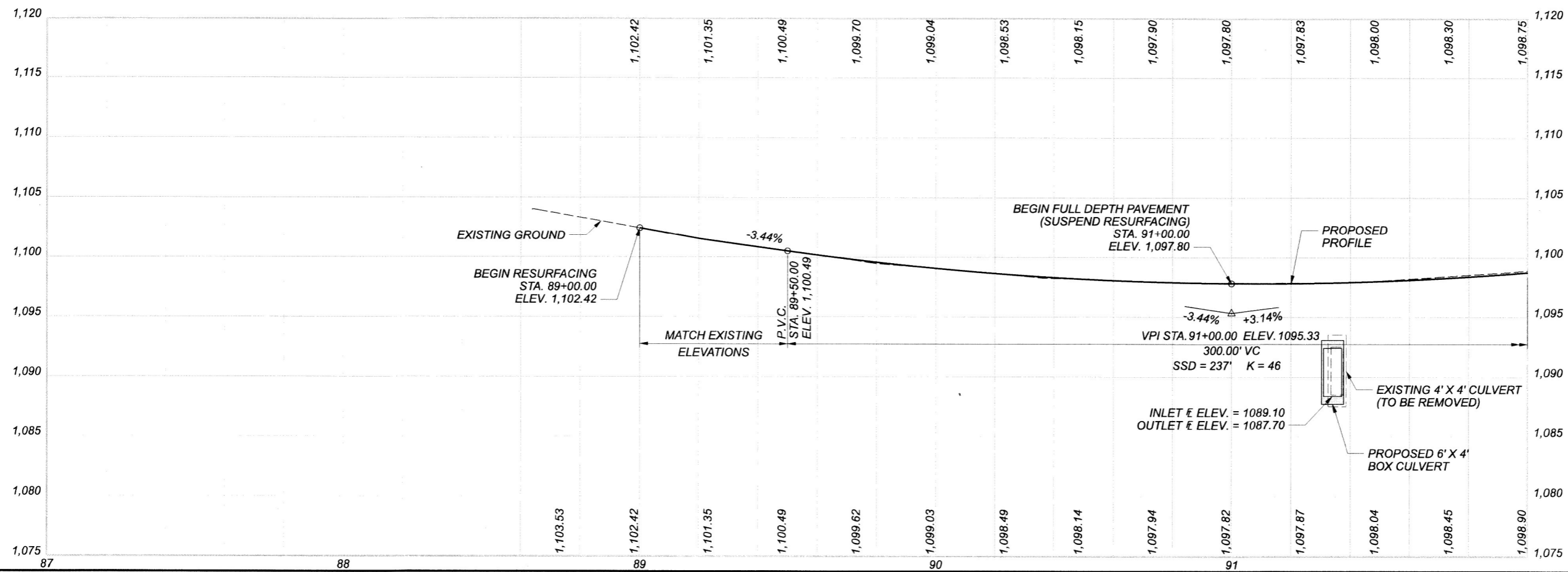

PLAN AND PROFILE - S.R. 39
 STA. 87+00.00 TO STA. 92+00.00

DESIGN AGENCY	
DESIGNER	JEP
REVIEWER	RG
PROJECT ID	111666
SHEET TOTAL	21 93

CROSS REFERENCES	
SHEET NO.	DESCRIPTION
23	ESTIMATED QUANTITIES
24-31	CROSS SECTIONS
52	SUPERELEVATION TABLES
57-64	CULVERT DETAILS

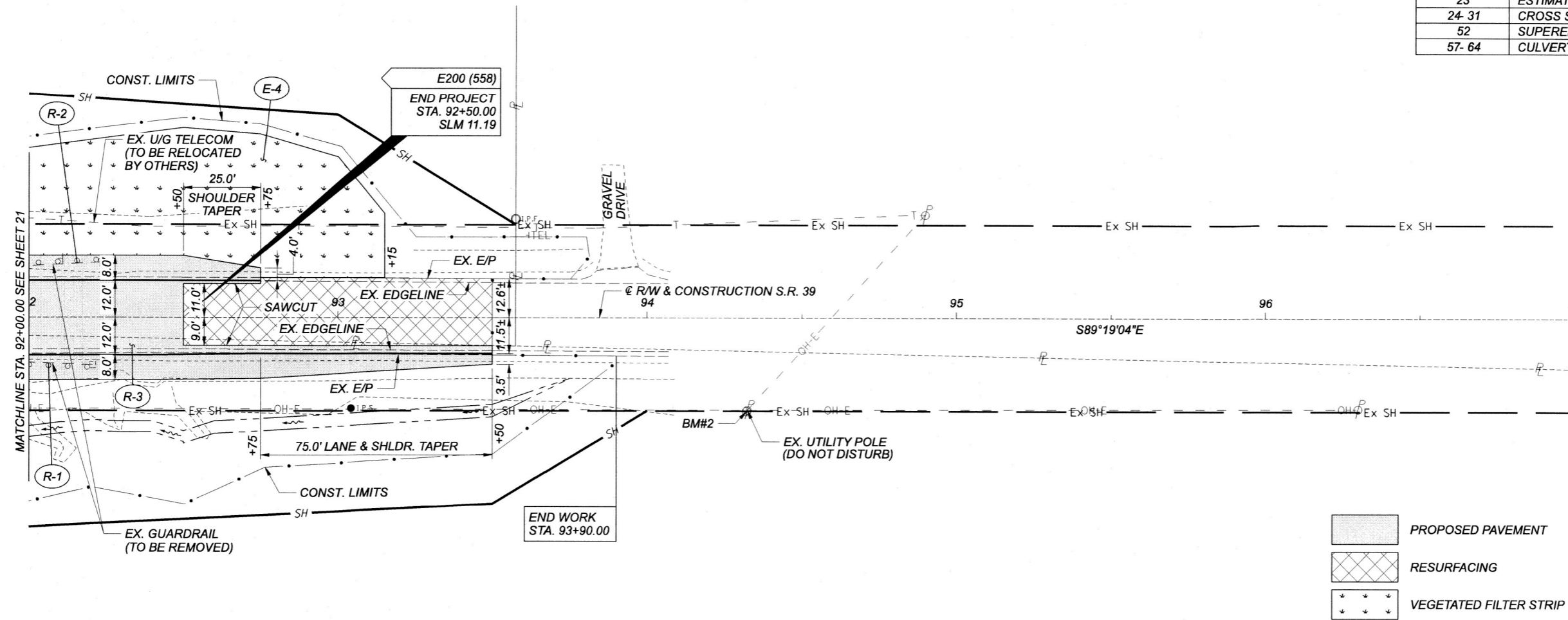
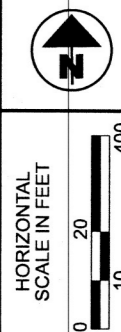

- PROPOSED PAVEMENT
- RESURFACING
- VEGETATED FILTER STRIP

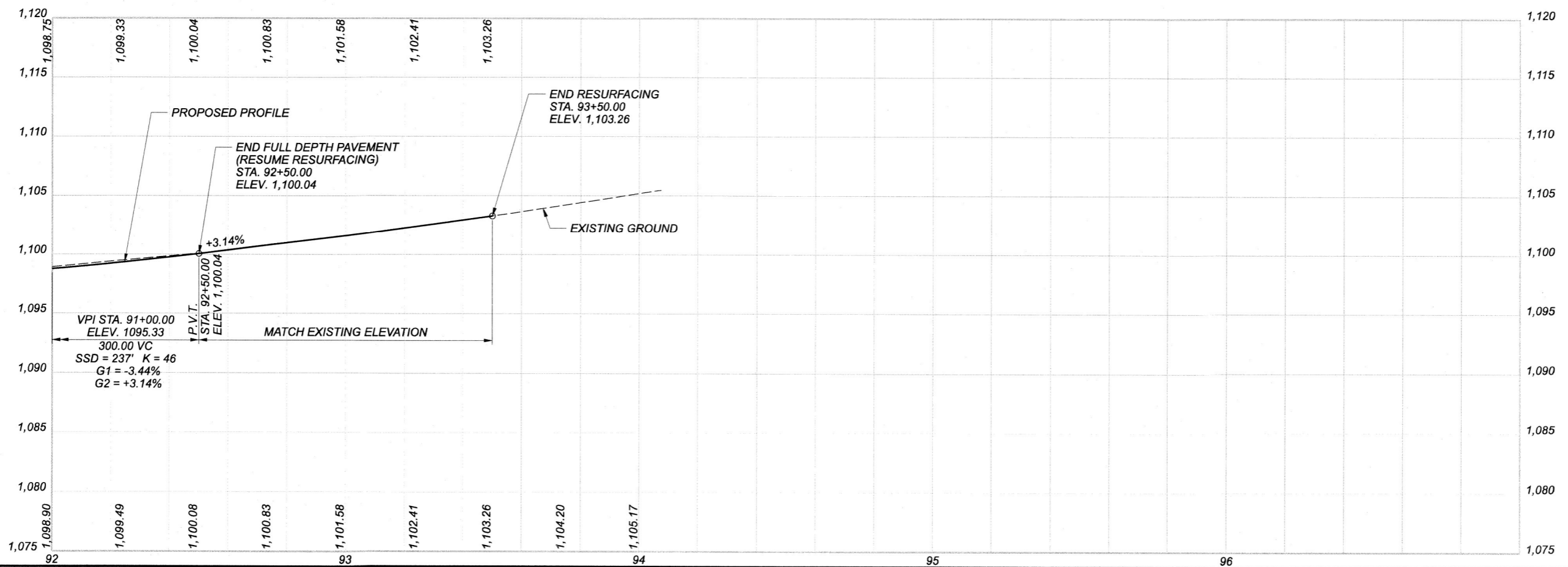

PLAN AND PROFILE - S.R. 39
 STA. 92+00.00 TO STA. 97+00.00

DESIGN AGENCY	
B.G. www.bggroup.com 9910 WILCOX PLACE, SUITE C DUBLIN, OHIO 43016	
DESIGNER	JEP
REVIEWER	RG
PROJECT ID	111666
SHEET	TOTAL
22	93

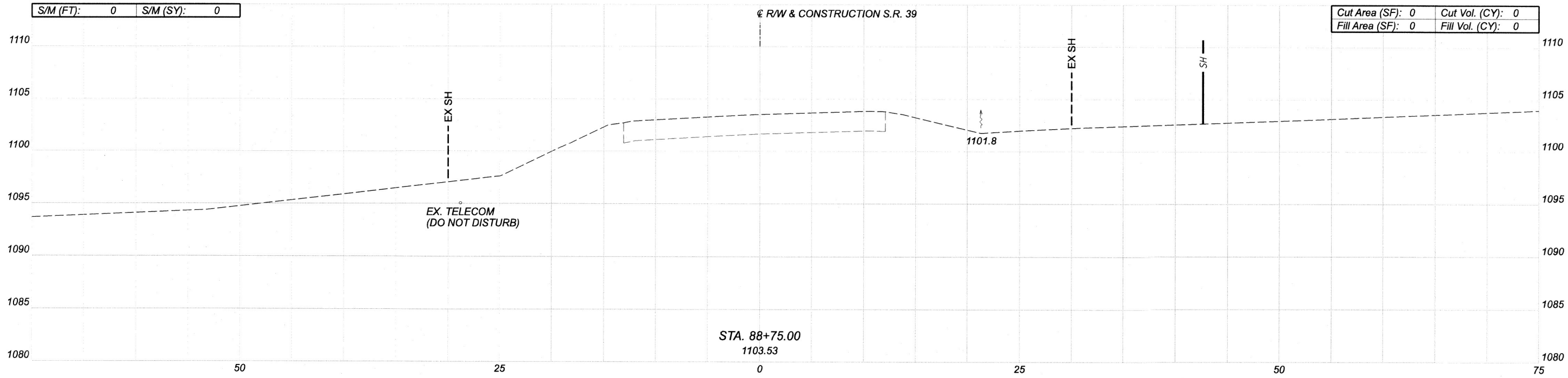
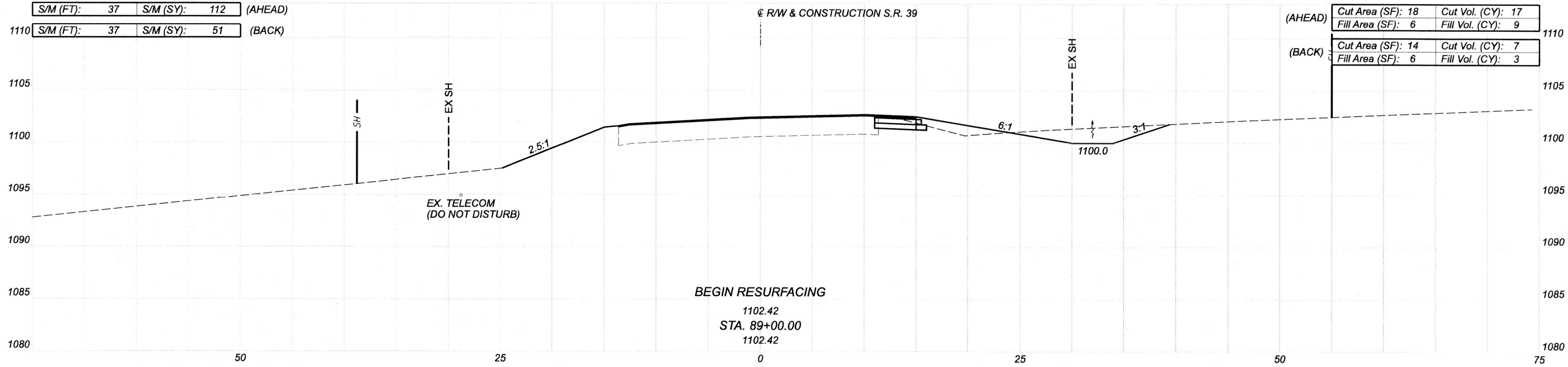

CROSS SECTIONS -- S.R. 39
 STA. 88+75.00 TO STA. 89+00.00

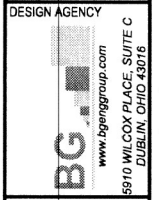

DESIGNER: JEP
 REVIEWER: RG
 DATE: 6-8-22

Sheet Totals			111666	
Seeding	Cut	Fill	SHEET	TOTAL
163	24	12	24	93

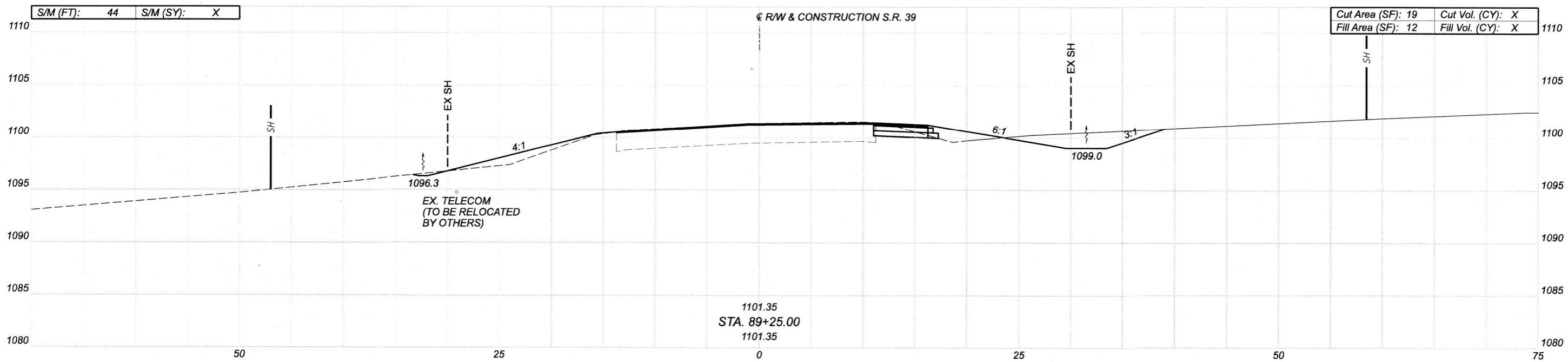
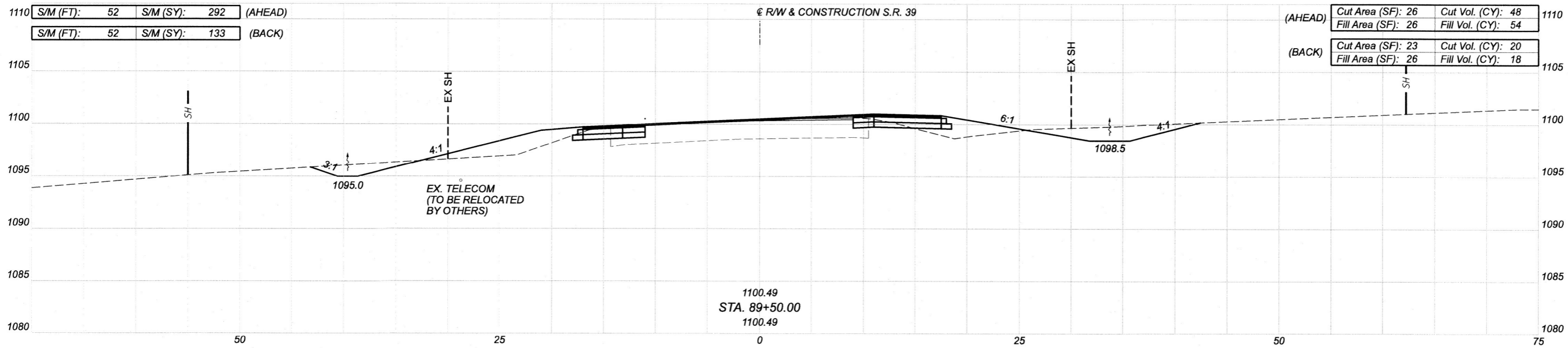

CROSS SECTIONS - S.R. 39
 STA. 89+25.00 TO STA. 89+50.00

DESIGN AGENCY				
 8910 W. COY. PLACE, SUITE C BURLINGAME, CA 94010				
DESIGNER				
JEP				
REVIEWER				
RG 6-8-22				
PROJECT ID				
111666				
Sheet Totals				
Seeding	Cut	Fill	SHEET	TOTAL
425	68	72	25	93

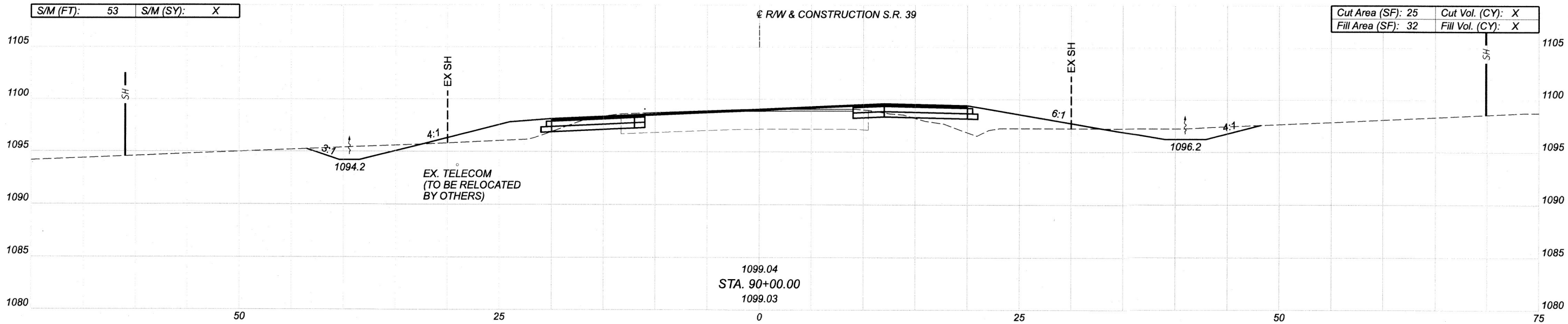
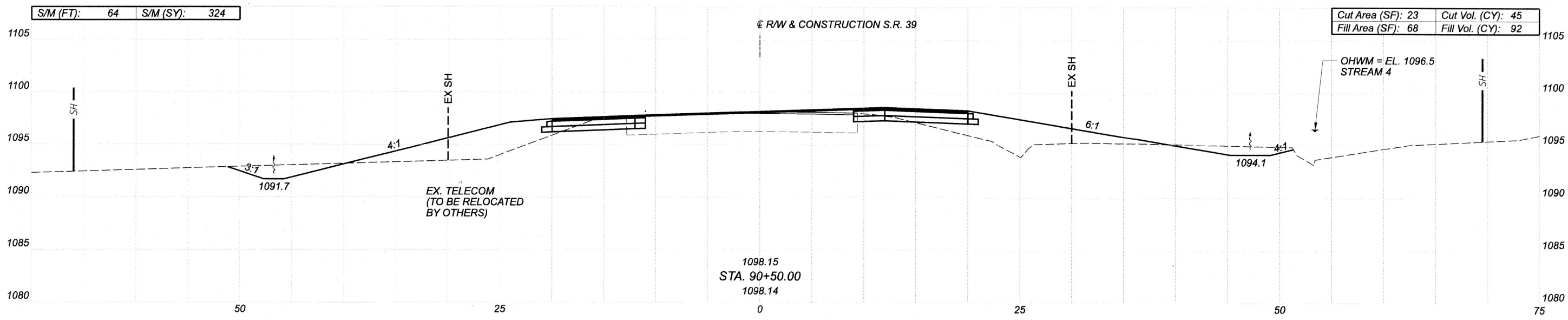

CROSS SECTIONS - S.R. 39
 STA. 90+00.00 TO STA. 90+50.00

Sheet Totals			111666	
Seeding	Cut	Fill	SHEET	TOTAL
324	45	92	26	93

DESIGN AGENCY

 www.bgroup.com
 8910 WILCOX PLACE, SUITE C
 DUBLIN, OHIO 43016

DESIGNER
 JEP

REVIEWER
 RG 6-8-22

PROJECT ID
 111666

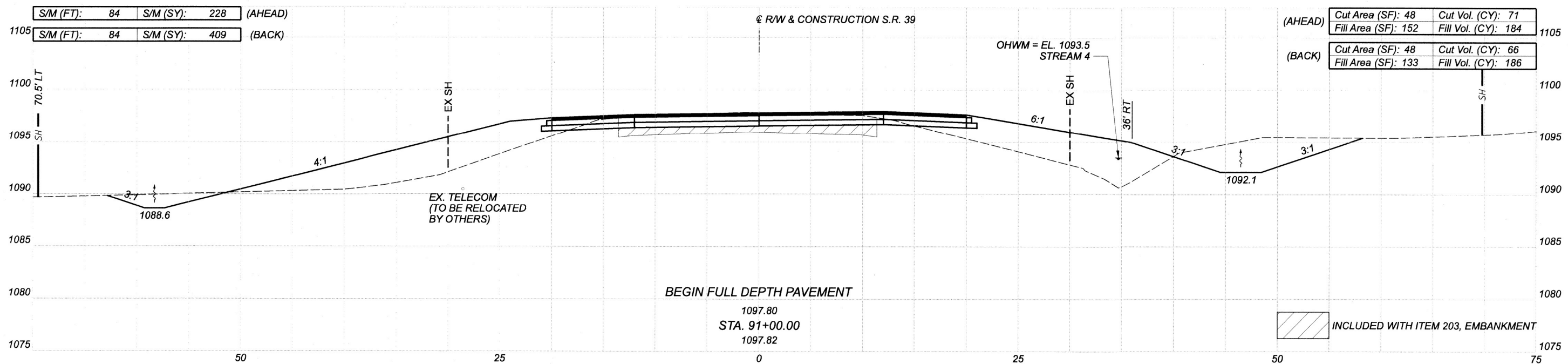
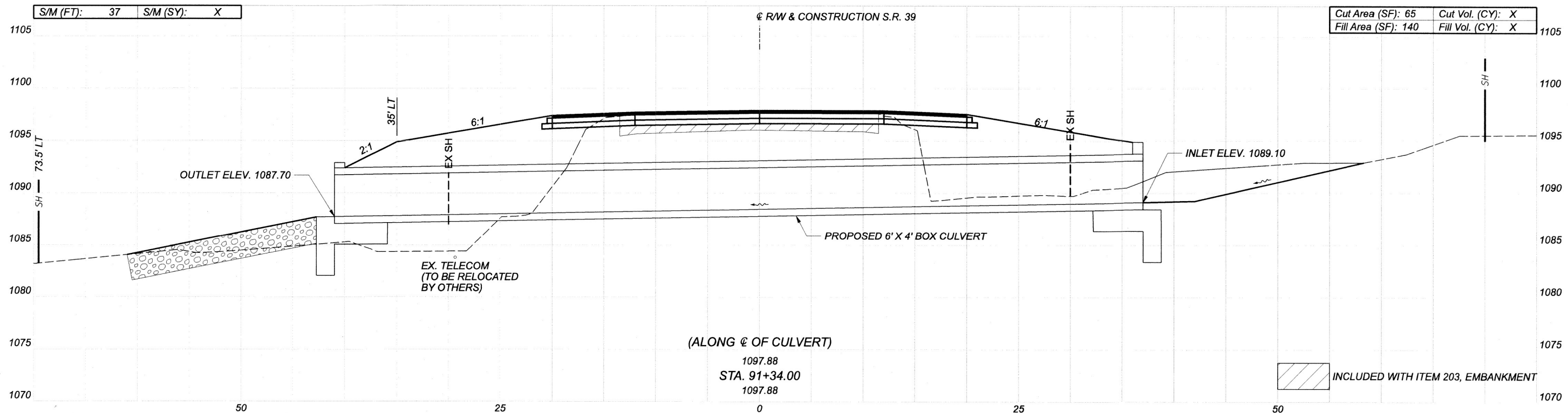

CROSS SECTIONS - S.R. 39
 STA. 91+00.00 TO STA. 91+34.00

DESIGN AGENCY
B.G.
 www.bgggroup.com
 9910 WILCOX PLACE, SUITE C
 DUBLIN, OHIO 43016

DESIGNER
 JEP

REVIEWER
 RG 6-8-22

PROJECT ID
 111666

Sheet Totals			111666	
Seeding	Cut	Fill	SHEET	TOTAL
637	137	370	27	93

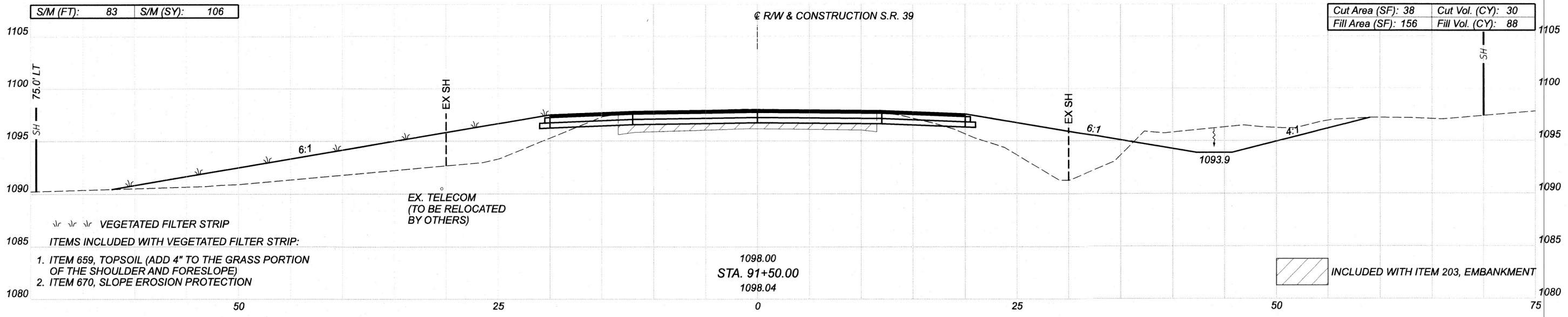
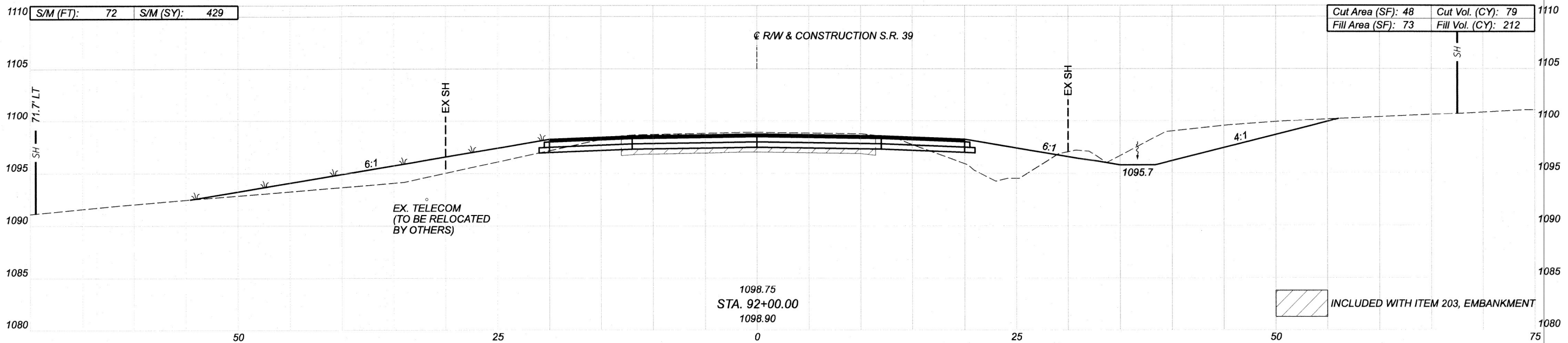

VEGETATED FILTER STRIP
 ITEMS INCLUDED WITH VEGETATED FILTER STRIP:
 1. ITEM 659, TOPSOIL (ADD 4" TO THE GRASS PORTION OF THE SHOULDER AND FORESLOPE)
 2. ITEM 670, SLOPE EROSION PROTECTION

Sheet Totals			
Seeding	Cut	Fill	TOTAL
535	199	300	93

DESIGN AGENCY
B.G.
 www.bgrgroup.com
 9910 WILCOX PLACE, SUITE C
 DUBLIN, OHIO 43016

DESIGNER
 JEP

REVIEWER
 RG 6-8-22

PROJECT ID
 111666

CROSS SECTIONS - S.R. 39
 STA. 91+50.00 TO STA. 92+00.00

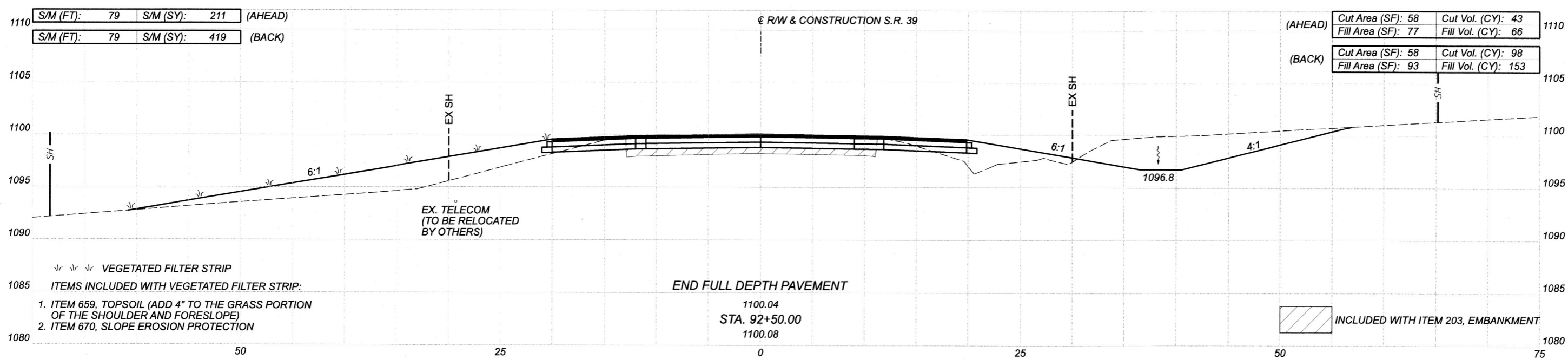
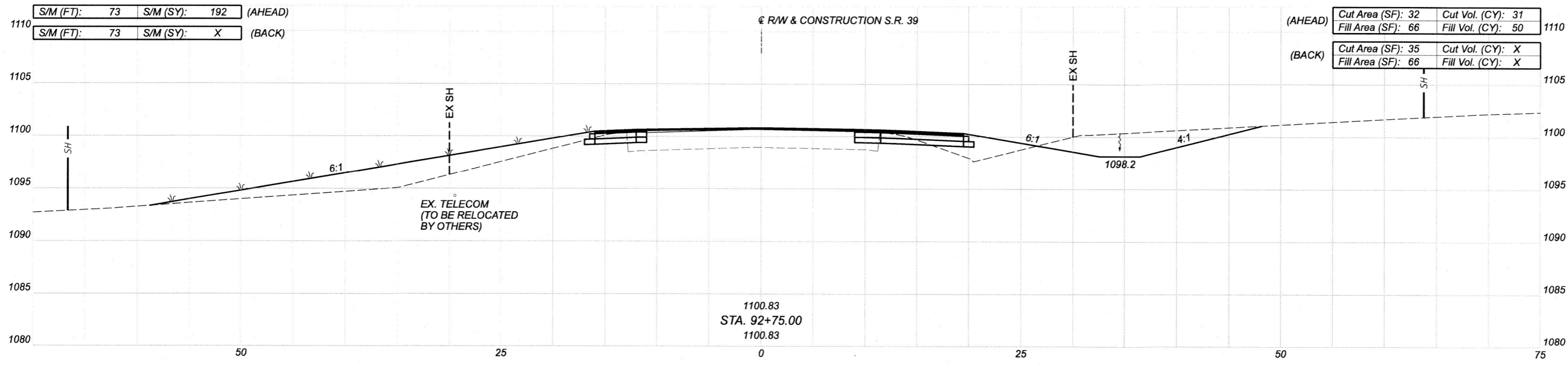

- VEGETATED FILTER STRIP
 ITEMS INCLUDED WITH VEGETATED FILTER STRIP:
- ITEM 659, TOPSOIL (ADD 4" TO THE GRASS PORTION OF THE SHOULDER AND FORESLOPE)
 - ITEM 670, SLOPE EROSION PROTECTION

END FULL DEPTH PAVEMENT

CROSS SECTIONS - S.R. 39
 STA. 92+50.00 TO STA. 92+75.00

DESIGN AGENCY	BG
DESIGNER	JEP
REVIEWER	RG
PROJECT ID	111666

Sheet Totals			111666
Seeding	Cut	Fill	SHEET TOTAL
822	172	269	29 93

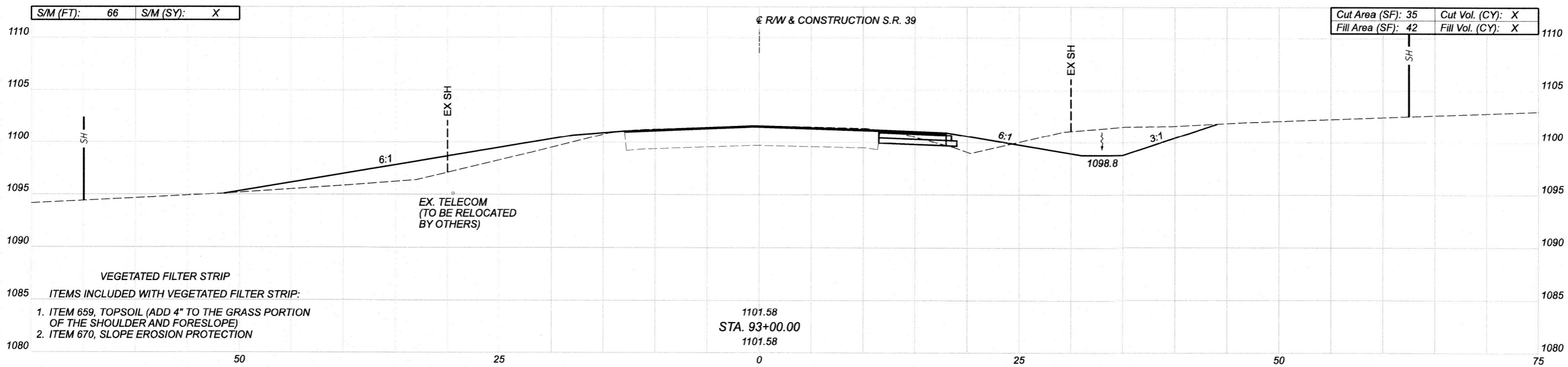
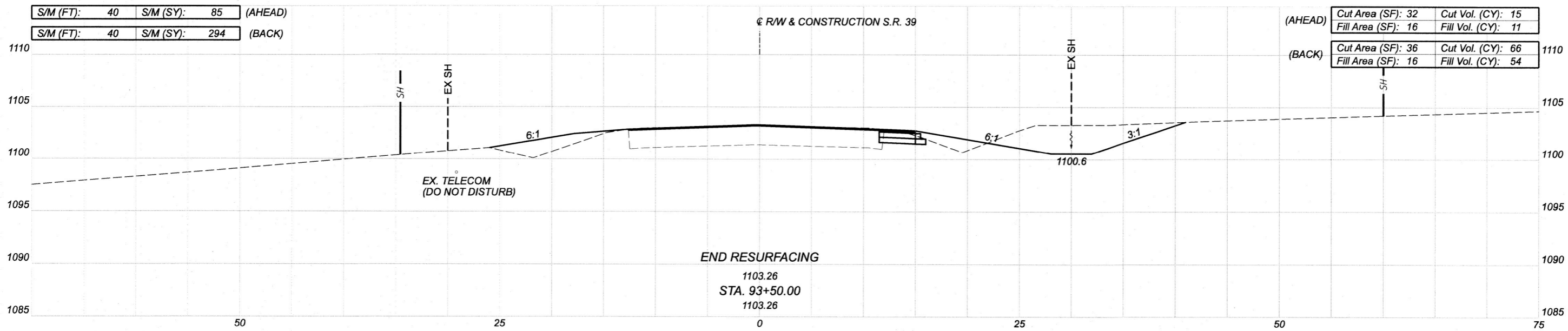

CROSS SECTIONS - S.R. 39
 STA. 93+00.00 TO STA. 93+50.00

DESIGN AGENCY
 BG
 www.bgggroup.com
 5910 WILCOX PLACE, SUITE C
 DUBLIN, OHIO 43016

DESIGNER
 JEP
 REVIEWER
 RG 6-8-22
 PROJECT ID
 111666

Sheet Totals			111666	
Seeding	Cut	Fill	SHEET	TOTAL
379	81	65	30	93

CROSS SECTION TOTALS	
S/M (SY):	3314*
CUT (CY):	636**
FILL (SY):	1183**

* = TOTALS CARRIED TO THE GENERAL NOTES
 ** = TOTALS CARRIED TO THE GENERAL SUMMARY

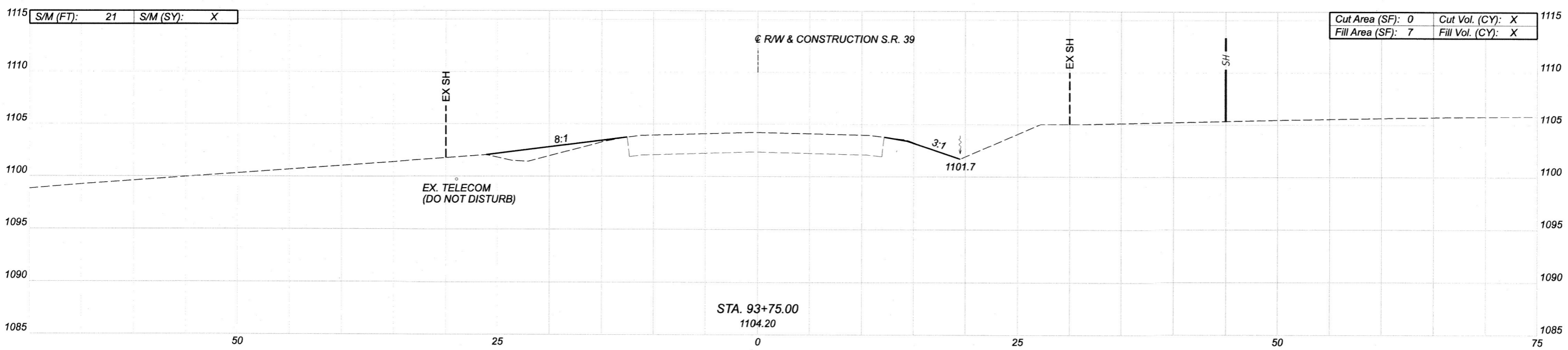
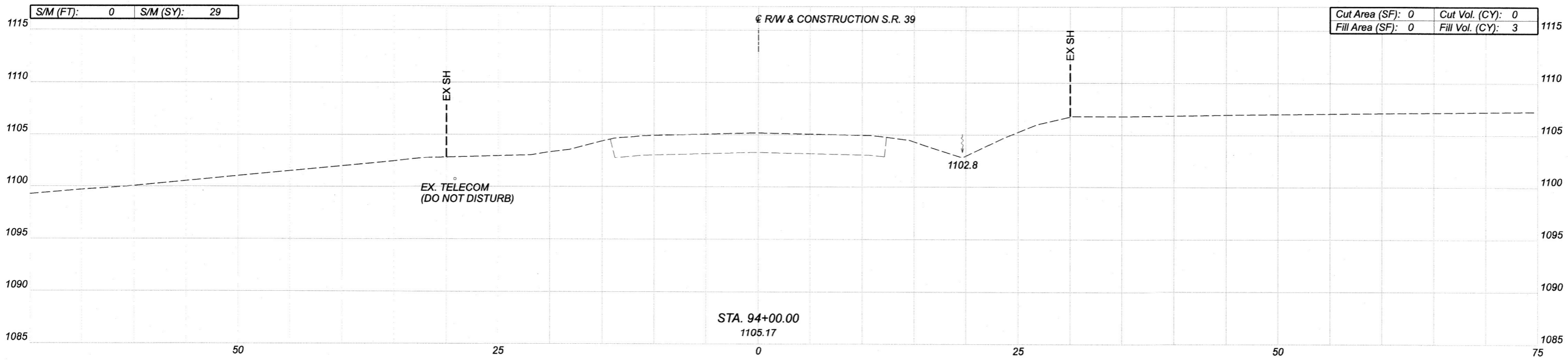

Sheet Totals			111666	
Seeding	Cut	Fill	SHEET	TOTAL
29	0	3	31	93

DESIGN AGENCY
B.G.
 www.bgggroup.com
 9510 WILCOX PLACE, SUITE C
 DUBLIN, OHIO 43016

DESIGNER
 JEP

REVIEWER
 RG 6-8-22

PROJECT ID
 111666

CROSS SECTIONS - S.R. 39
 STA. 93+75.00 TO STA. 94+00.00







HORIZONTAL SCALE IN FEET
0 20 40

PLAN AND PROFILE - S.R. 754
STA. 202+00.00 TO STA. 207+50.00

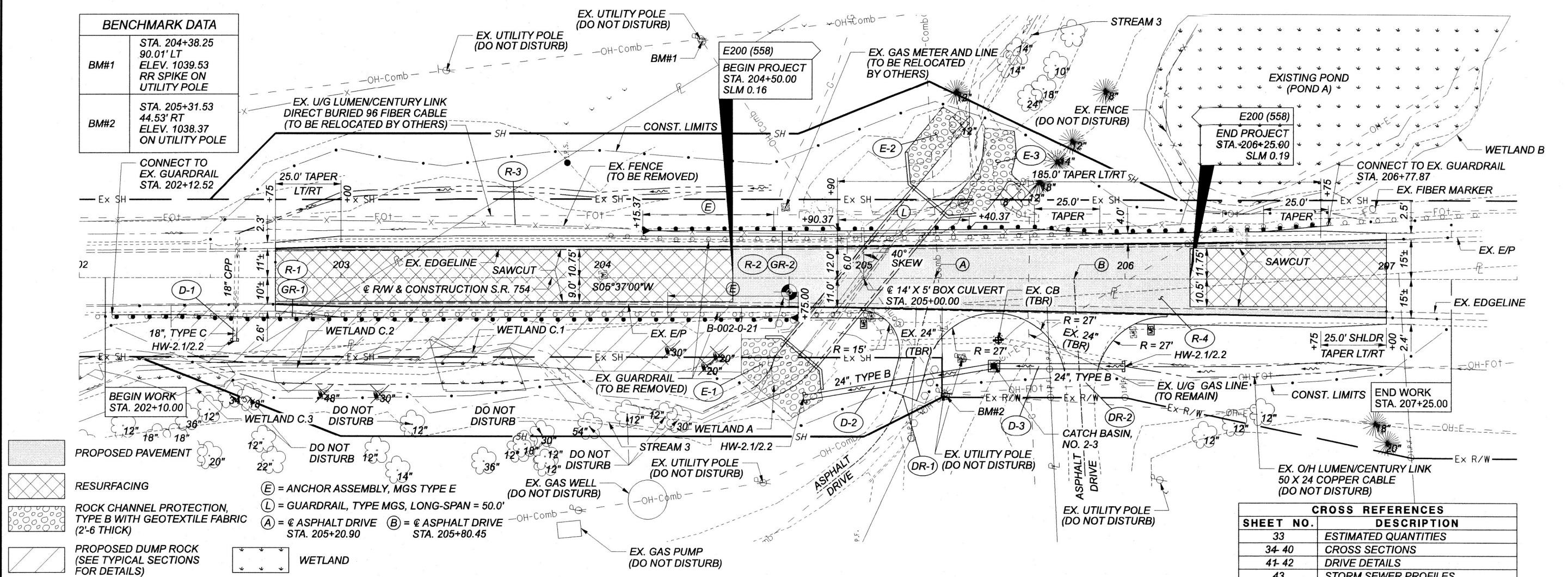
DESIGN AGENCY	
	
DESIGNER	JEP
REVIEWER	RG 6-8-22
PROJECT ID	111666
SHEET TOTAL	32 93

BENCHMARK DATA	
BM#1	STA. 204+38.25 90.01' LT ELEV. 1039.53 RR SPIKE ON UTILITY POLE
BM#2	STA. 205+31.53 44.53' RT ELEV. 1038.37 ON UTILITY POLE

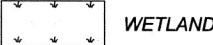

-  PROPOSED PAVEMENT
-  RESURFACING
-  ROCK CHANNEL PROTECTION, TYPE B WITH GEOTEXTILE FABRIC (2'-6" THICK)
-  PROPOSED DUMP ROCK (SEE TYPICAL SECTIONS FOR DETAILS)
-  WETLAND
- (E) = ANCHOR ASSEMBLY, MGS TYPE E
- (L) = GUARDRAIL, TYPE MGS, LONG-SPAN = 50.0'
- (A) = ASPHALT DRIVE (B) = ASPHALT DRIVE STA. 205+80.45

CROSS REFERENCES	
SHEET NO.	DESCRIPTION
33	ESTIMATED QUANTITIES
34-40	CROSS SECTIONS
41-42	DRIVE DETAILS
43	STORM SEWER PROFILES
65-71	CULVERT DETAILS

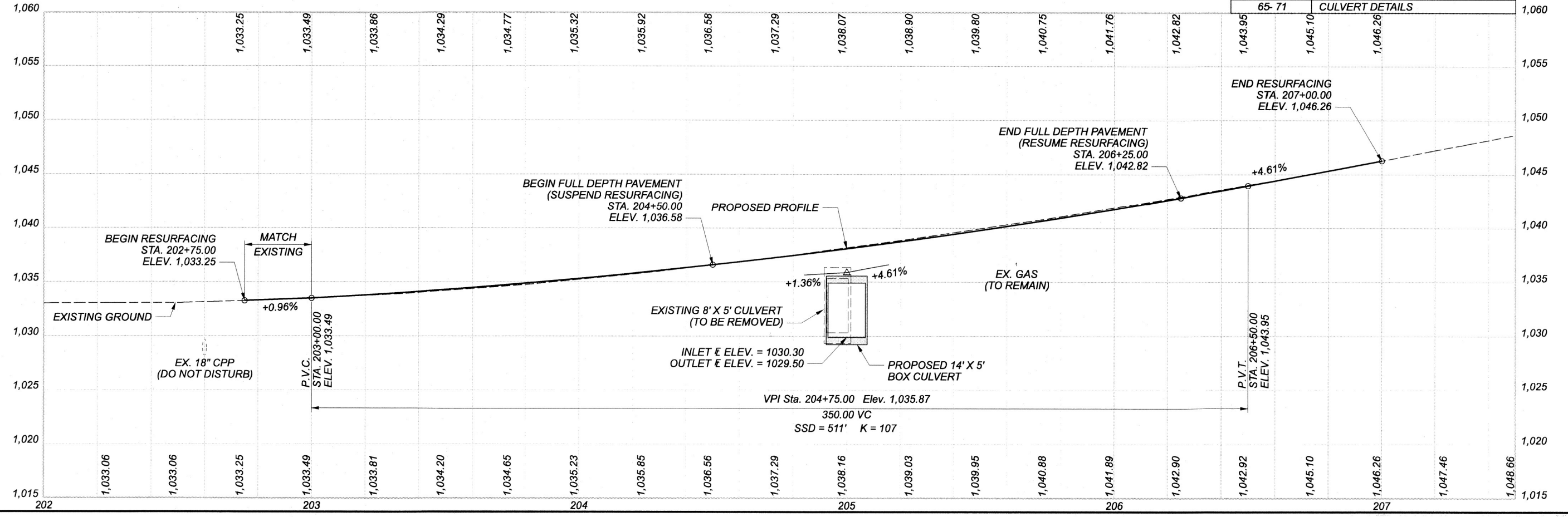

HOL-39/754-11.17.0.16, TUS-93-10.80

MODEL: CLX-J - Plan [Sheet] PAPER SIZE: 17x11 (in.) DATE: 7/14/2022 TIME: 10:55:50 PM USER: JPerchinske
 P:\Transportation\Work\Sets\11666.HOL-39-118-400-Engineering\Roadway\Sheets\11666.HOL-754-0018_GP200.dgn

REF. NO.	SHEET NO.	STATION TO STATION	SIDE	202					204	304	441	601	602	606			611			690
				PAVEMENT REMOVED SQ YD	PIPE REMOVED, 24" AND UNDER FEET	GUARDRAIL REMOVED FEET	CATCH BASIN REMOVED EACH	FENCE REMOVED FEET	SUBGRADE COMPACTION SQ YD	6" AGGREGATE BASE CU YD		2" ASPHALT CONCRETE SURFACE COURSE, TYPE 1, (449), AS PER PLAN (PG10-22M) CU YD	ROCK CHANNEL PROTECTION, TYPE B WITH GEOTEXTILE FABRIC CU YD	CONCRETE MASONRY CU YD	GUARDRAIL, TYPE MGS FEET	GUARDRAIL, TYPE MGS, LONG-SPAN FEET	ANCHOR ASSEMBLY, MGS TYPE E EACH	CATCH BASIN, NO. 2-3 EACH	18" CONDUIT, TYPE C FEET	
		S.R. 754																		
D-1	32	202+60	RT		3							0.33					5			
D-2	32	204+77 - 205+50	RT		49		1					0.46				1		74		
D-3	32	205+50 - 206+00	RT		52							0.46						50		
DR-1	32	205+20.90	RT	40				65	11	4									1	
DR-2	32	205+80.45	RT	41				72	12	4									1	
E-1	32	204+53 - 204+84	RT								57									
E-2	32	205+16 - 205+41	LT								30									
E-3	32	205+30 - 205+55	LT								42									
GR-1	32	202+12.52 - 204+75.00	RT										212.5			1				
GR-2	32	204+15.37 - 206+77.87	LT										162.5	50		1				
R-1	32	202+13 - 205+12	RT			304														
R-2	32	204+02 - 206+78	LT			277														
R-3	32	202+58 - 206+23	LT																	
R-4	32	202+75 - 207+00	LT/RT	574																
TOTALS CARRIED TO GENERAL SUMMARY				655	104	581	1	369	137	23	8	129	1.25	375.0	50	2	1	5	124	2

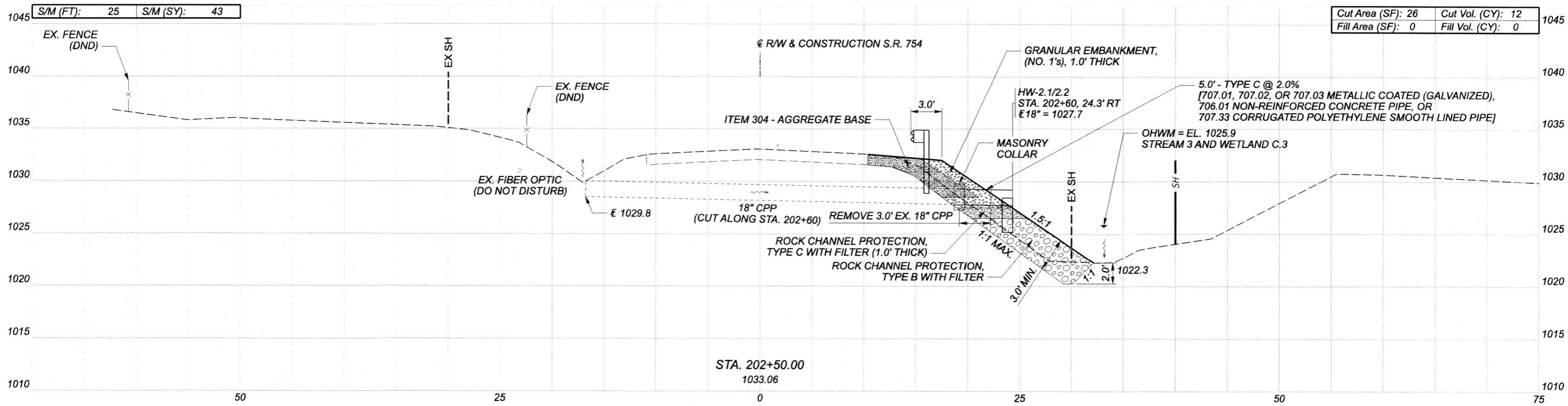

Cut Area (SF):	26	Cut Vol. (CY):	12
Fill Area (SF):	0	Fill Vol. (CY):	0

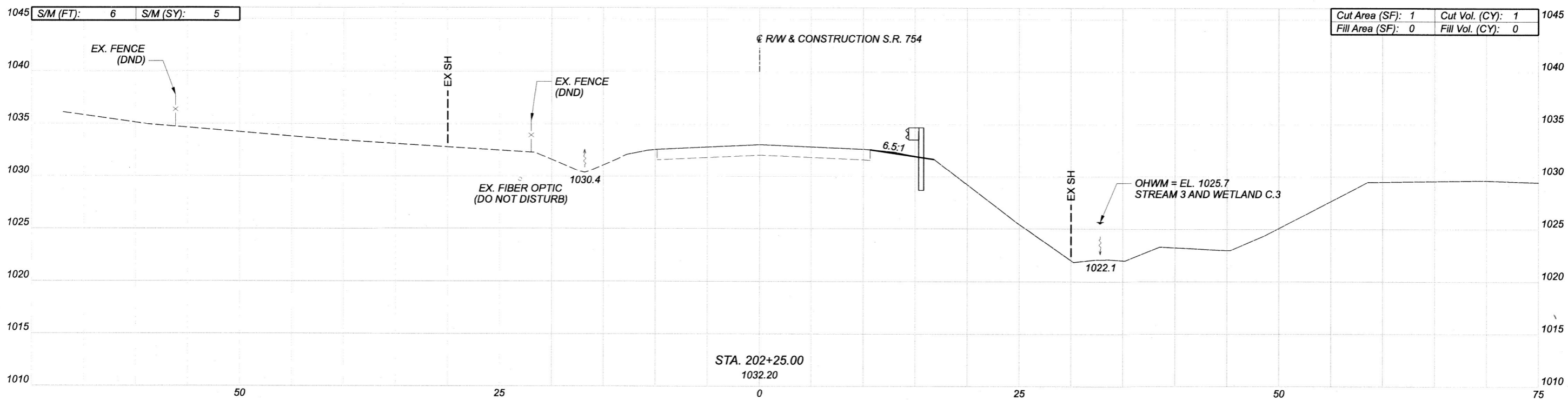

Cut Area (SF):	1	Cut Vol. (CY):	1
Fill Area (SF):	0	Fill Vol. (CY):	0

CROSS SECTIONS - S.R. 754
 STA. 202+25.00 TO STA. 202+50.00

Sheet Totals			PROJECT ID	
Seeding	Cut	Fill	SHEET	TOTAL
48	13	0	34	93

DESIGN AGENCY

 www.bginc.com
 5910 WILCOX PLACE, SUITE C
 DUBLIN, OHIO 43016

DESIGNER
 JEP

REVIEWER
 RG 6-8-22

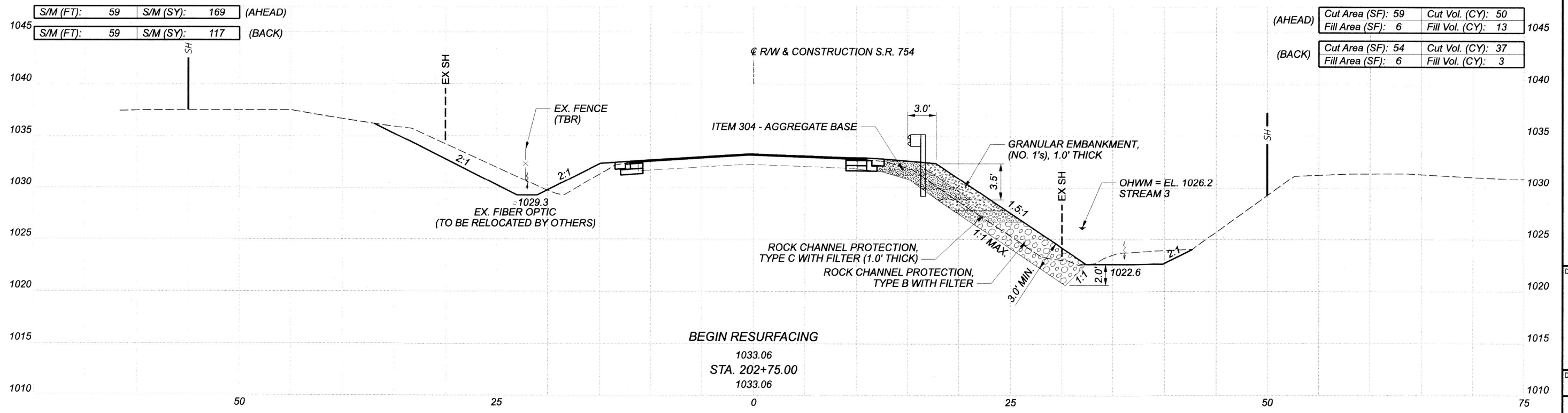
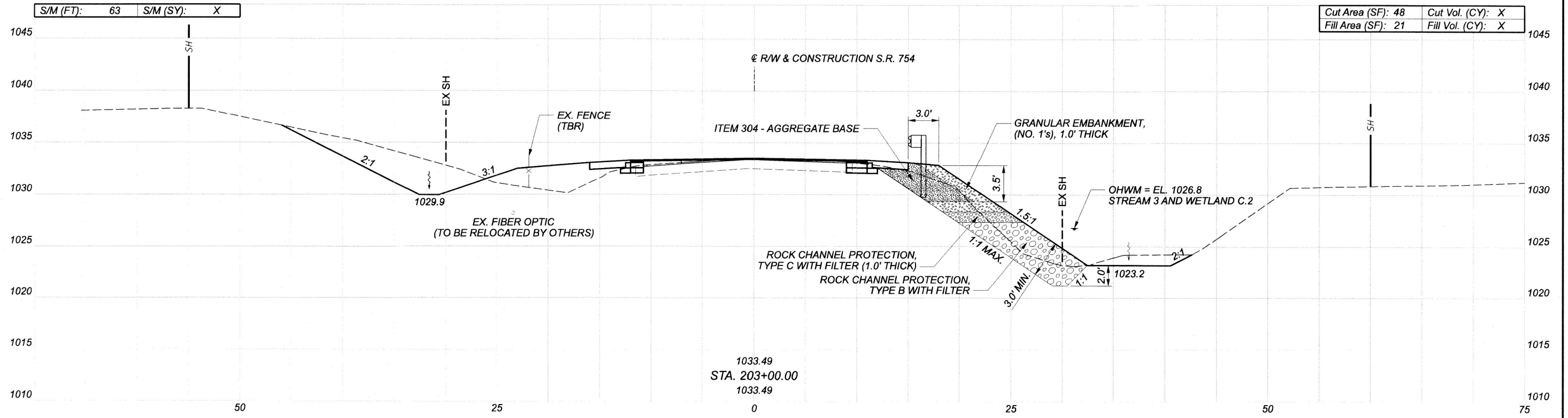
PROJECT ID
 111666



BEGIN RESURFACING
 1033.06
 STA. 202+75.00
 1033.06

CROSS SECTIONS - S.R. 754
 STA. 202+75.00 TO STA. 203+00.00

DESIGN AGENCY

 5910 WILCOX PLACE, SUITE C
 DUBLIN, OHIO 43016

DESIGNER
 JEP

REVIEWER
 RG 6-8-22

PROJECT ID
 111666

Sheet Totals			111666	
Sheet	Cut	Fill	SHEET	TOTAL
286	53	50	35	93

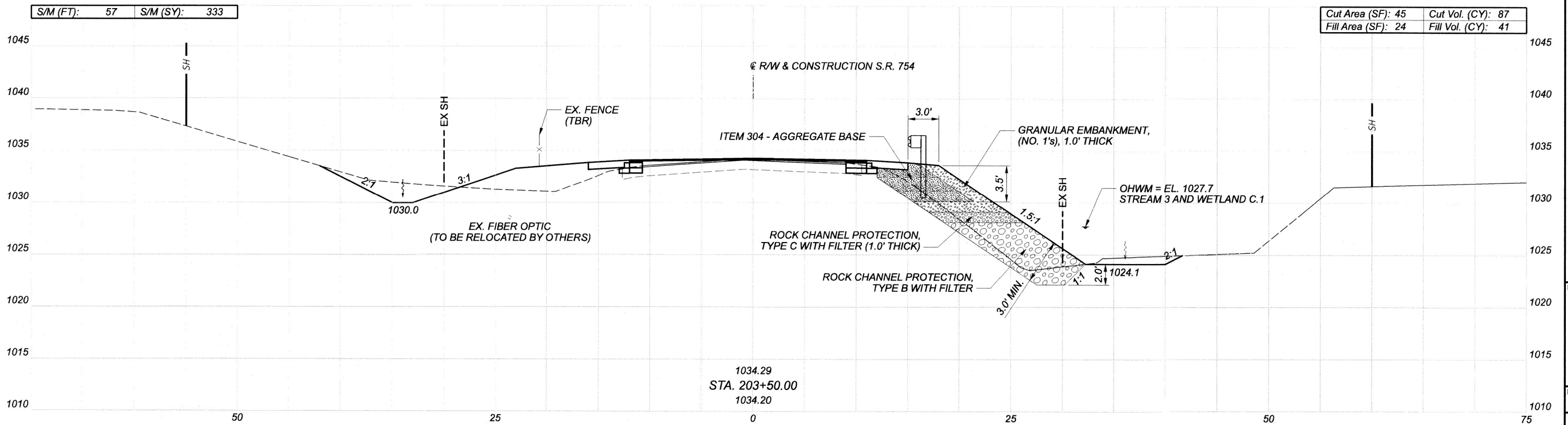
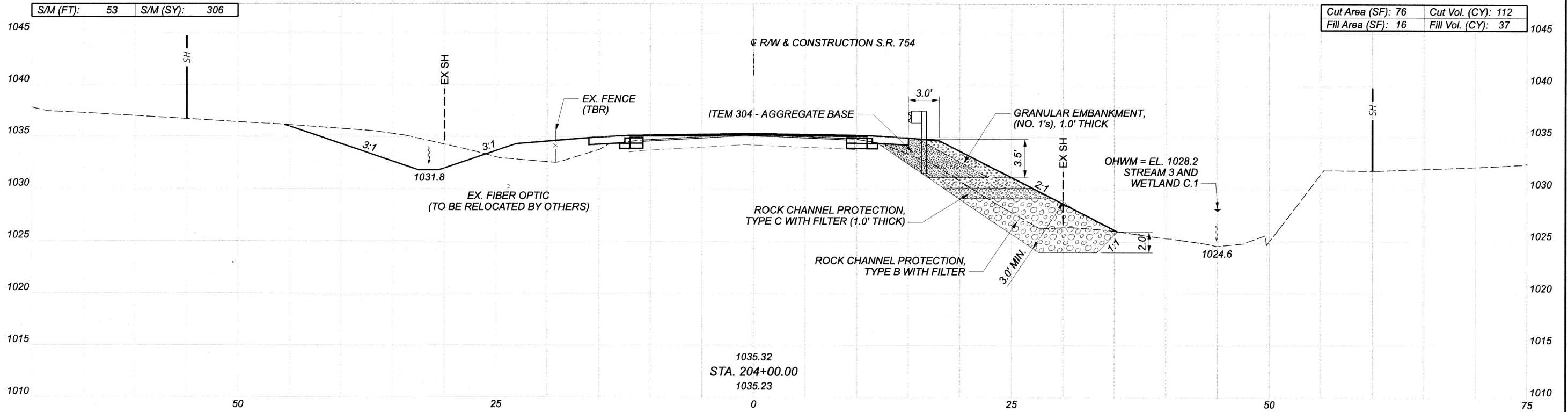

CROSS SECTIONS - S.R. 754
 STA. 203+50.00 TO STA. 204+00.00

DESIGN AGENCY
B.G.
 www.bggroup.com
 5910 WILCOX PLACE, SUITE C
 DUBLIN, OHIO 43016

DESIGNER
 JEP
 REVIEWER
 RG 6-8-22
 PROJECT ID
 111666

Sheet Totals			111666	
Seeding	Cut	Fill	SHEET	TOTAL
639	199	78	36	93

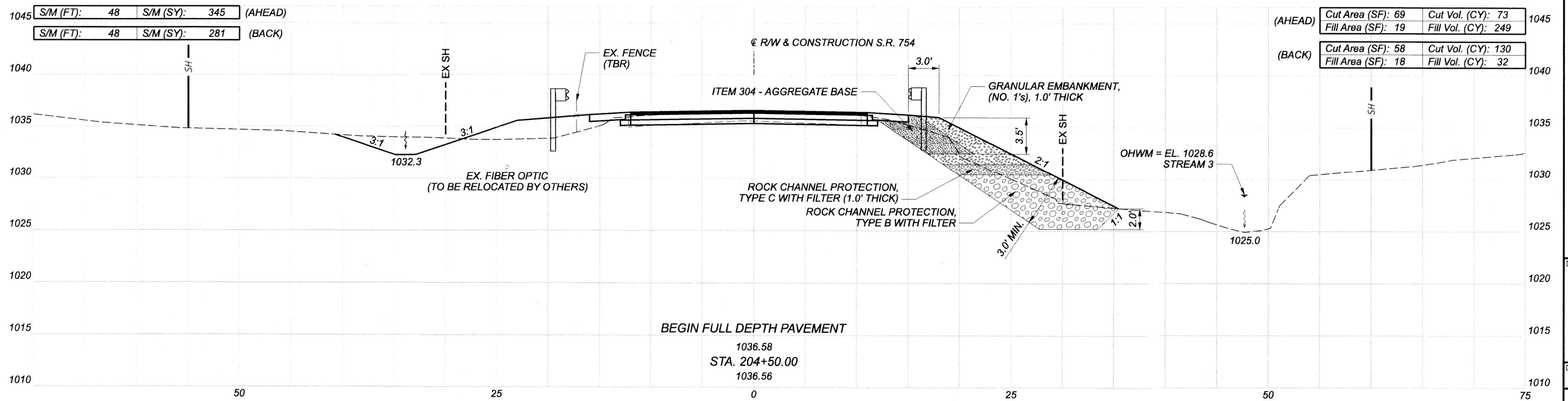
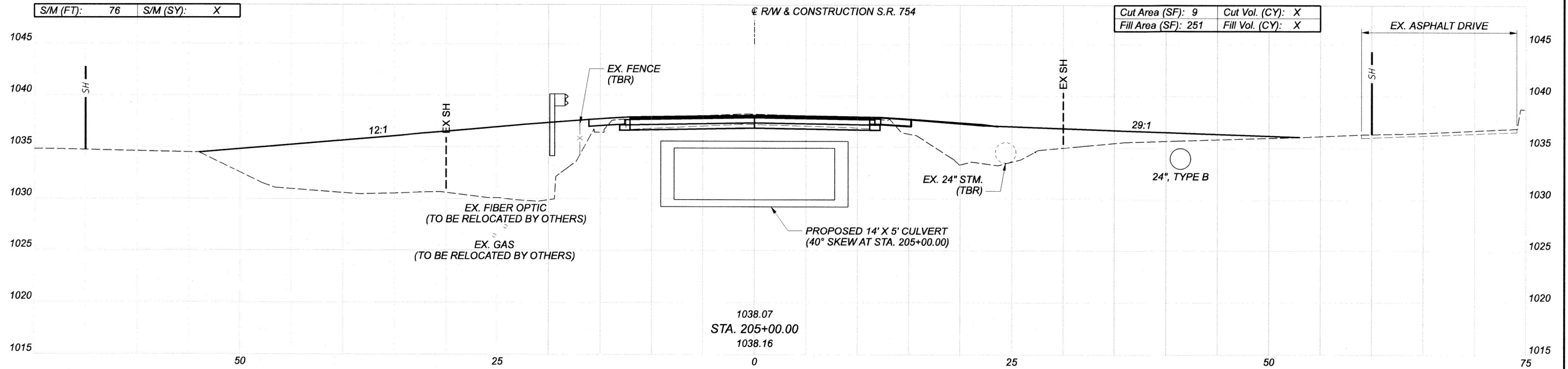

CROSS SECTIONS - S.R. 754
 STA. 204+50.00 TO STA. 205+00.00

DESIGN AGENCY
 BG
 www.bginfinity.com
 5910 WILCOX PLACE, SUITE C
 DUBLIN, OHIO 43016

DESIGNER
 JEP

REVIEWER
 RG 6-8-22

PROJECT ID
 111666

Sheet Totals			111666	
Seeding	Cut	Fill	SHEET	TOTAL
626	203	281	37	93

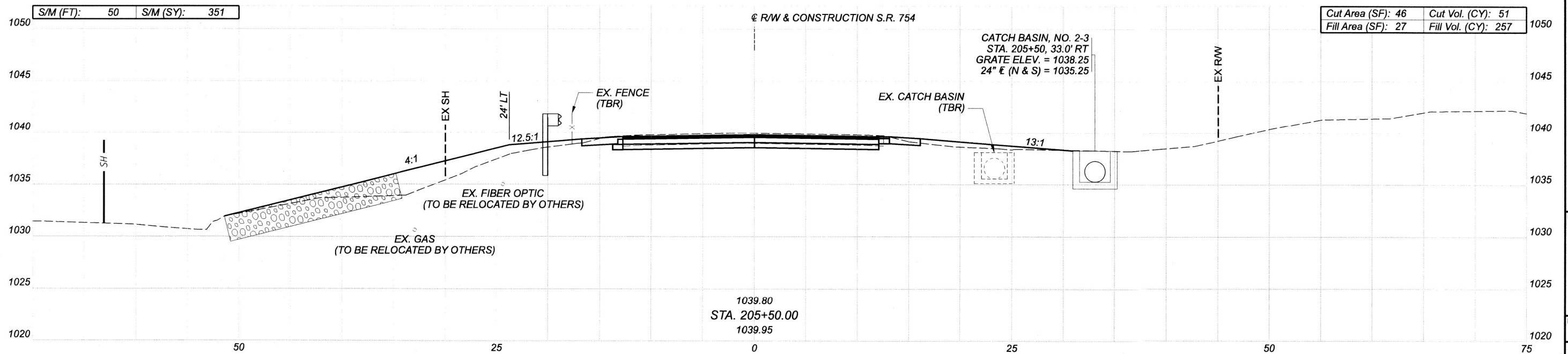
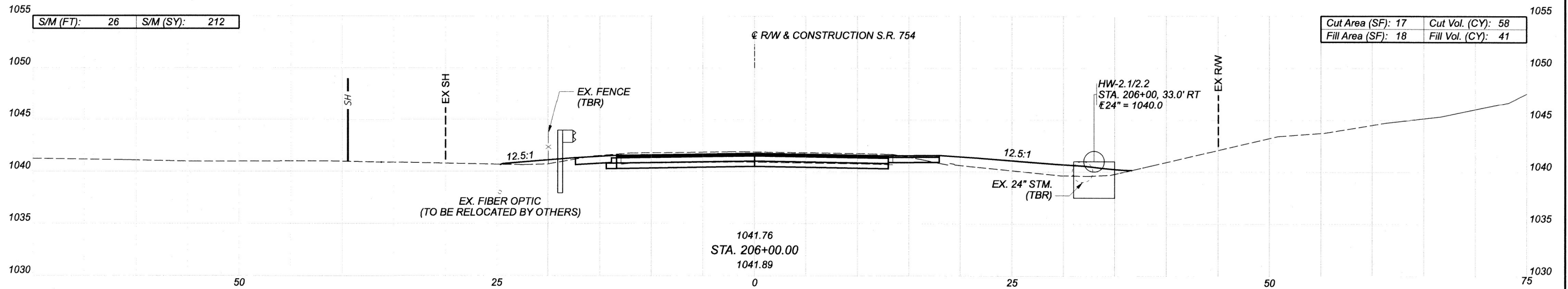
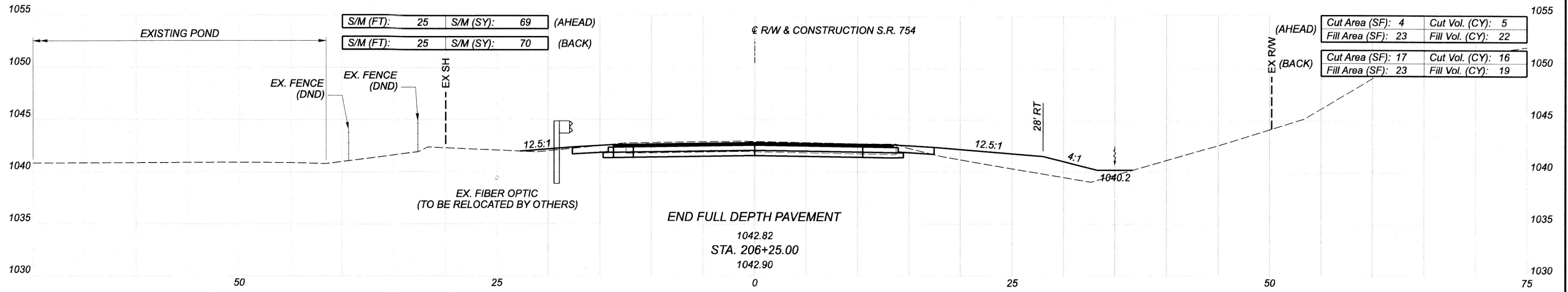

Sheet Totals			SHEET	TOTAL
Seeding	Cut	Fill		
702	130	339	38	93

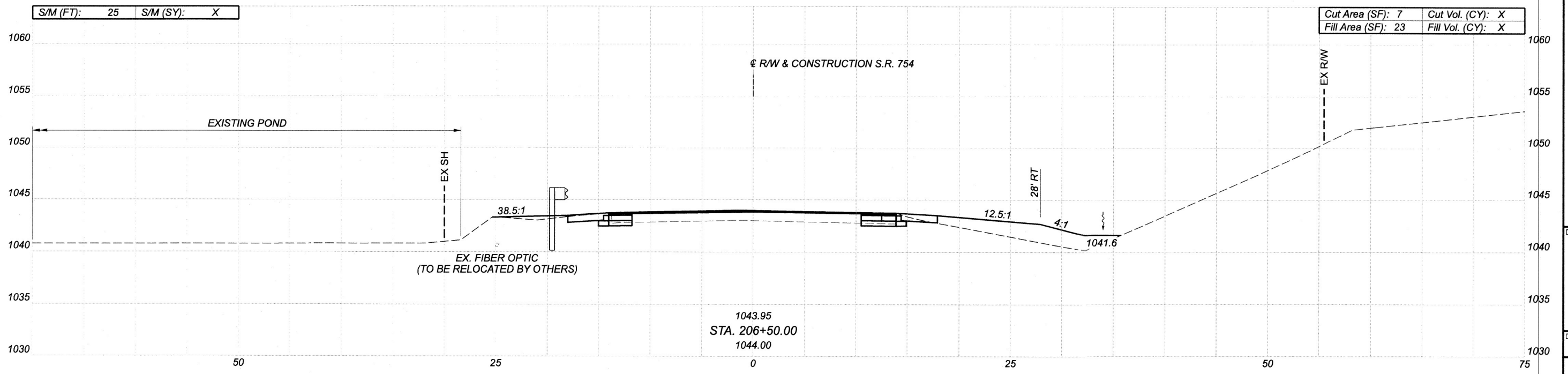
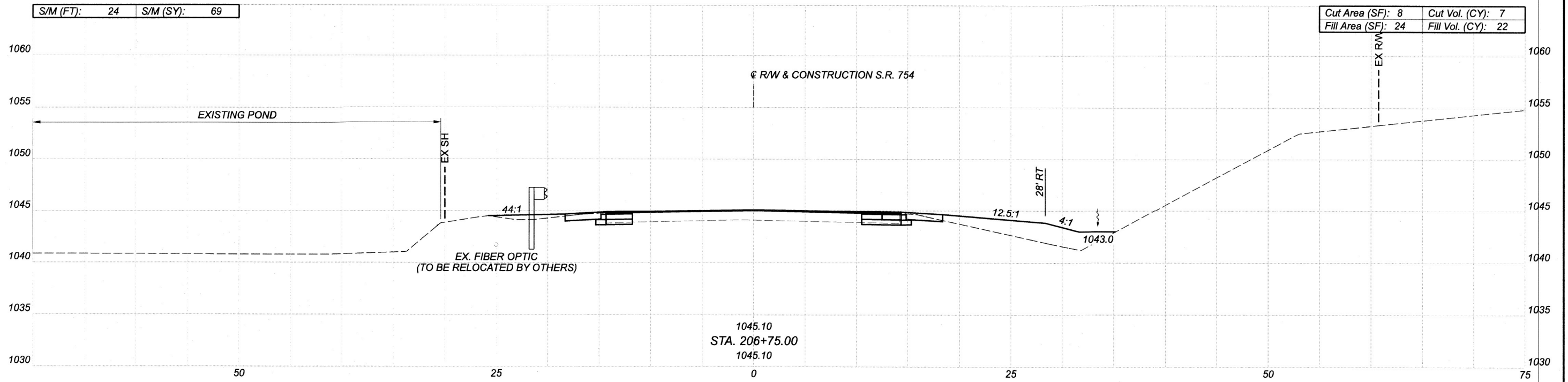

CROSS SECTIONS - S.R. 754
 STA. 206+50.00 TO STA. 206+75.00

DESIGN AGENCY
B.G.
 www.bggroup.com
 5910 WILCOX PLACE, SUITE C
 DUBLIN, OHIO 43016

DESIGNER
 JEP
 REVIEWER
 RG 6-8-22

PROJECT ID
 111666

Sheet Totals			111666	
Sheet	Cut	Fill	SHEET	TOTAL
69	7	22	39	93

CROSS SECTION TOTALS	
S/M (SY):	2460*
CUT (CY):	646**
FILL (SY):	753**

* = TOTALS CARRIED TO THE GENERAL NOTES
 ** = TOTALS CARRIED TO THE GENERAL SUMMARY

S/M (FT):	0	S/M (SY):	X
-----------	---	-----------	---

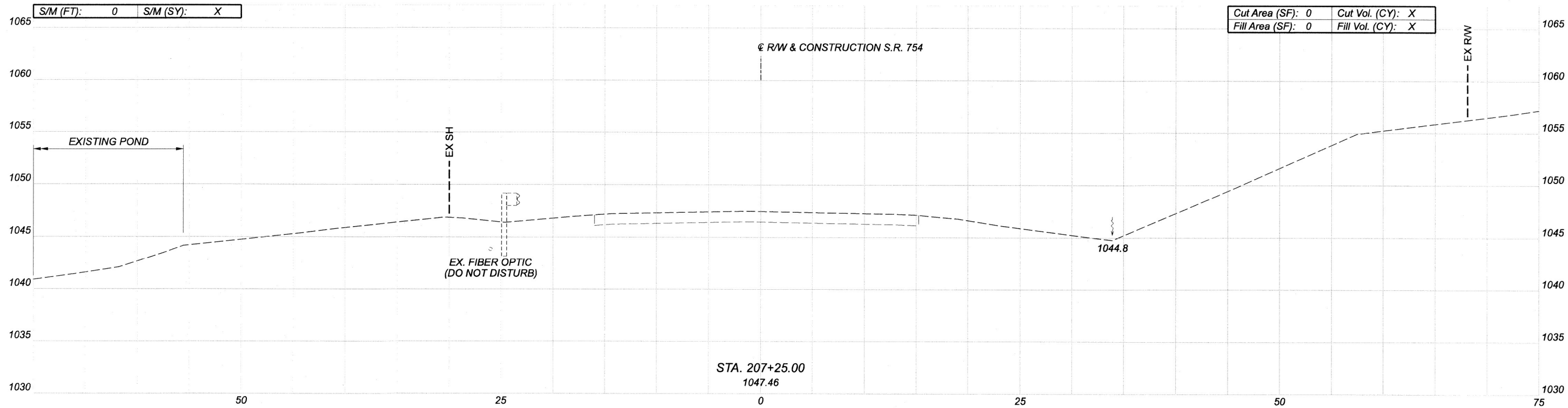

Cut Area (SF):	0	Cut Vol. (CY):	X
Fill Area (SF):	0	Fill Vol. (CY):	X

S/M (FT):	20	S/M (SY):	28	(AHEAD)
S/M (FT):	20	S/M (SY):	62	(BACK)

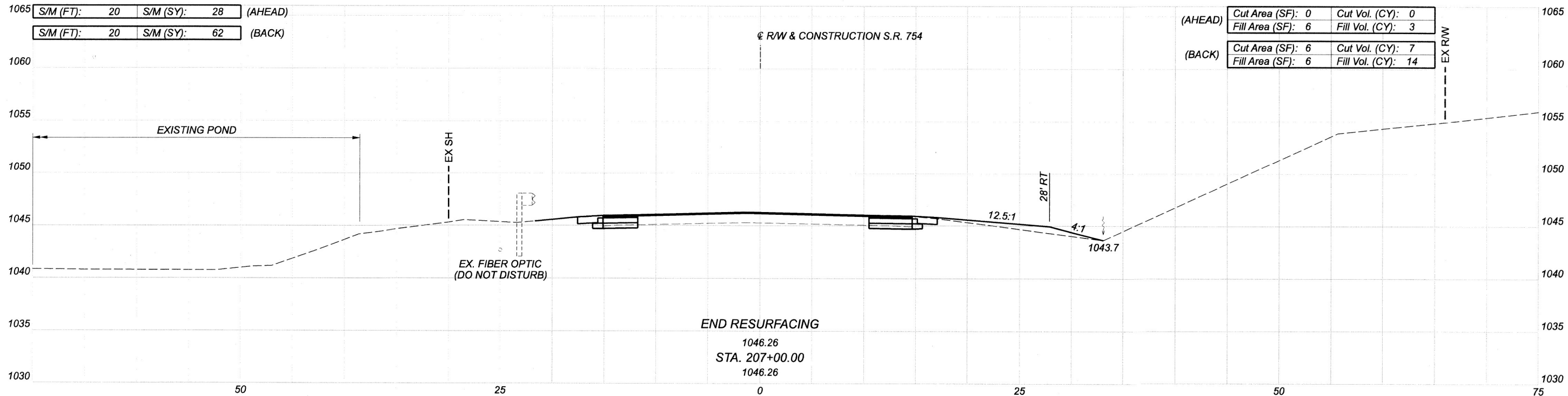

(AHEAD) Cut Area (SF):	0	Cut Vol. (CY):	0
(AHEAD) Fill Area (SF):	6	Fill Vol. (CY):	3
(BACK) Cut Area (SF):	6	Cut Vol. (CY):	7
(BACK) Fill Area (SF):	6	Fill Vol. (CY):	14

END RESURFACING
 1046.26
 STA. 207+00.00
 1046.26

Sheet Totals			111666	
Seeding	Cut	Fill	SHEET	TOTAL
90	10	17	40	93

DESIGN AGENCY
B.G.
 www.bggroup.com
 5910 WILCOX PLACE, SUITE C
 DUBLIN, OHIO 43015
 DESIGNER
 JEP
 REVIEWER
 RG
 6-8-22
 PROJECT ID
 111666

CROSS SECTIONS - S.R. 754
 STA. 207+00.00 TO STA. 207+25.00

HOL-39/754-11.17/0.16, TUS-93-10.80

MODEL: Sheet PAPER: 17x11 (in.) DATE: 7/14/2022 TIME: 10:07:02 PM USER: JPerchinske
 P:\Transportation\Worksets\11666.HOL-39-118\400-Engineering\Roadway\Sheet\11666.HOL-754-008_GD2000.dgn

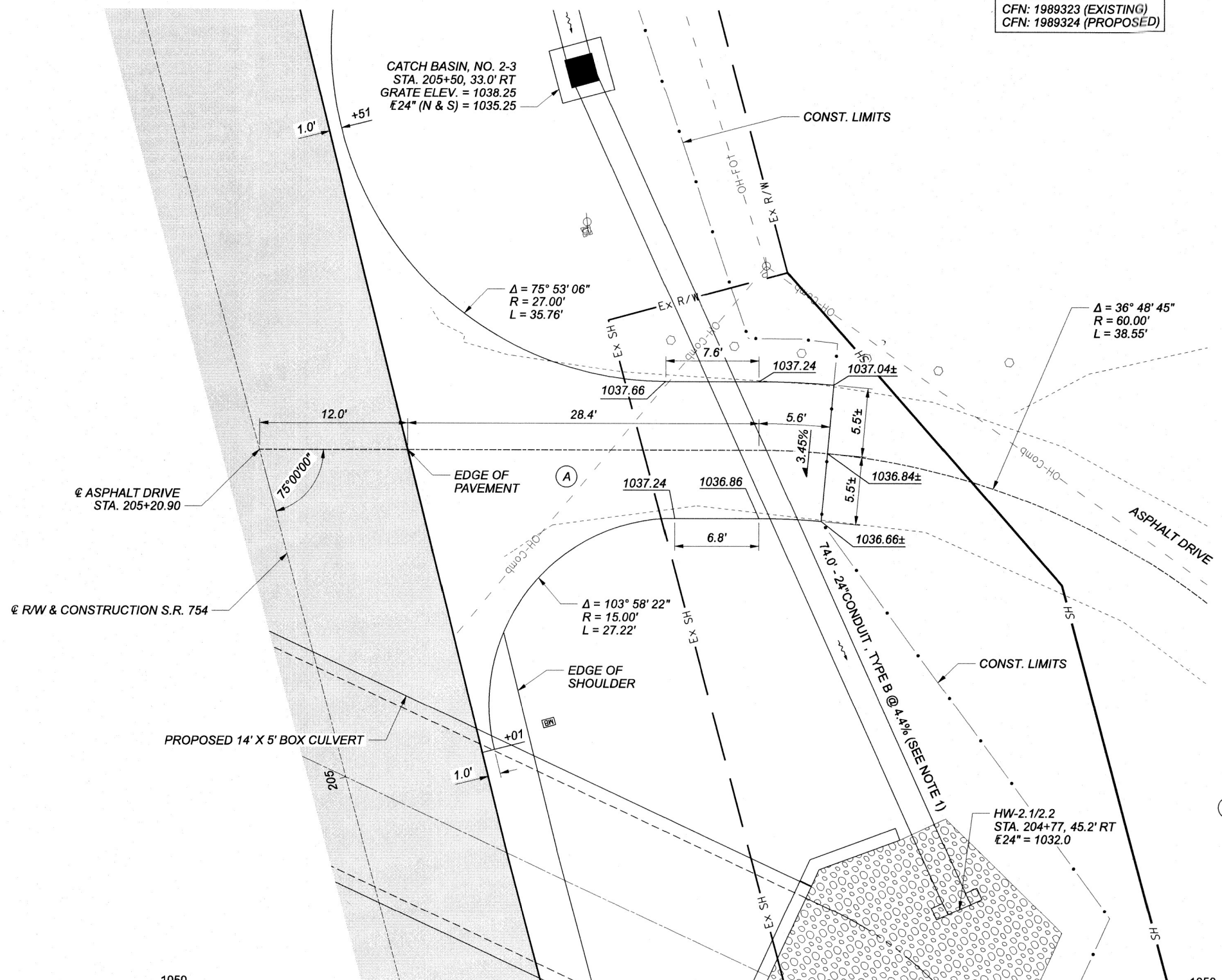

CFN: 1989323 (EXISTING)
 CFN: 1989324 (PROPOSED)

NOTE 1:
 ALLOWABLE PIPE MATERIALS INCLUDE:
 [707.01, 707.02, OR 707.03 METALLIC COATED (GALVANIZED),
 706.01 NON-REINFORCED CONCRETE PIPE, OR
 707.33 CORRUGATED POLYETHYLENE SMOOTH LINED PIPE]

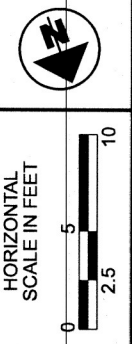

DRIVE DETAILS - S.R. 754
 STA. 205+20.90, RT

(A) = RESIDENTIAL DRIVE BUILD-UP:
 ITEM 441 - 2" ASPHALT CONCRETE SURFACE COURSE,
 TYPE 1, (449), AS PER PLAN (PG70-22M)
 ITEM 304 - 6" AGGREGATE BASE

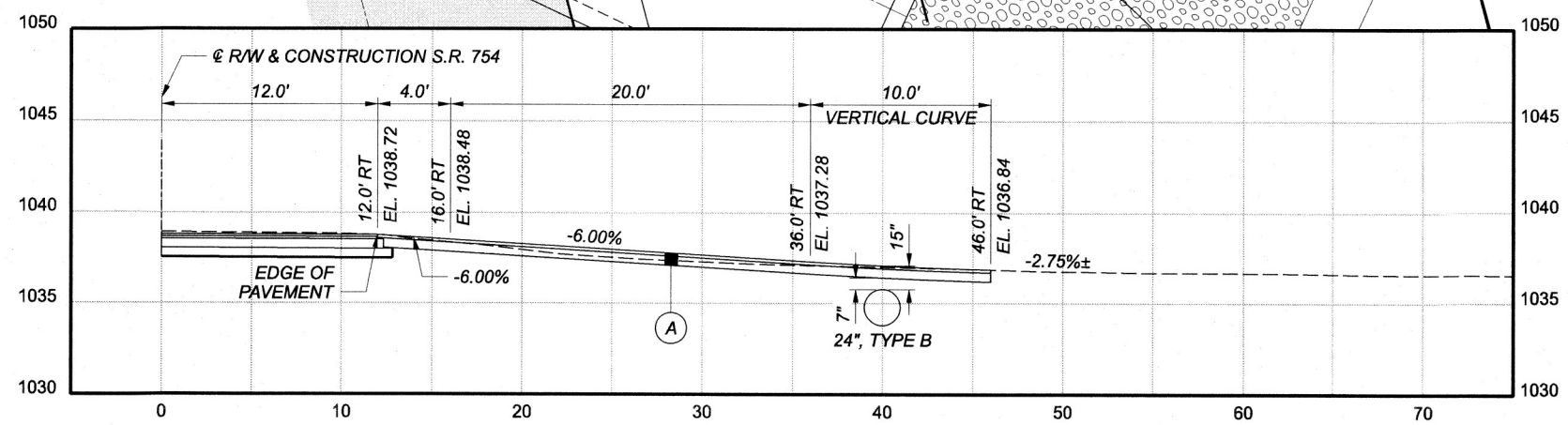

DESIGN AGENCY	
BG www.bgrgroup.com 5910 WILCOX PLACE, SUITE C DUBLIN, OHIO 43016	
DESIGNER	JEP
REVIEWER	RG
PROJECT ID	6-8-22
SHEET	11666
TOTAL	41
41 93	

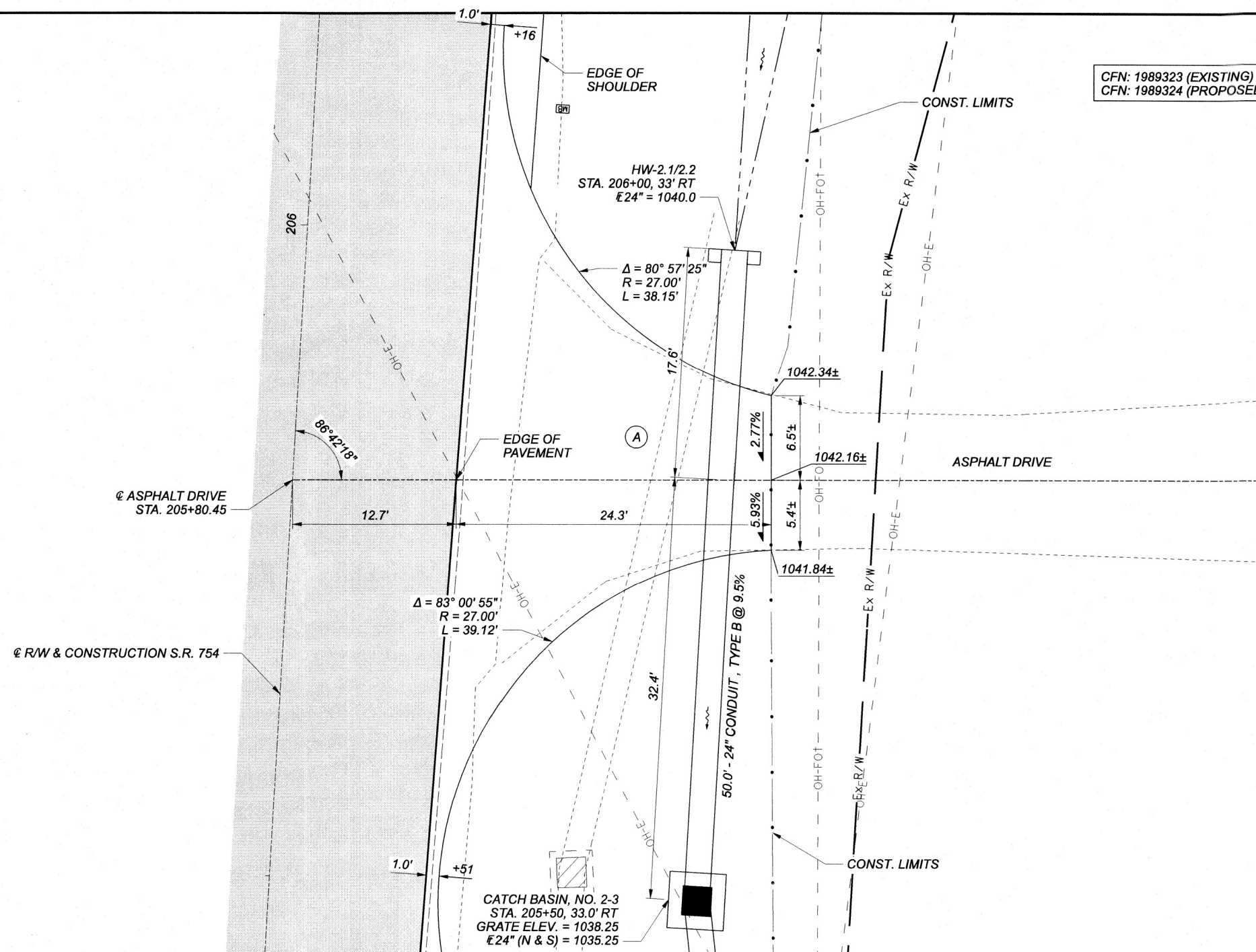

CFN: 1989323 (EXISTING)
 CFN: 1989324 (PROPOSED)

NOTE 1:
 ALLOWABLE PIPE MATERIALS INCLUDE:
 [707.01, 707.02, OR 707.03 METALLIC COATED (GALVANIZED),
 706.01 NON-REINFORCED CONCRETE PIPE, OR
 707.33 CORRUGATED POLYETHYLENE SMOOTH LINED PIPE]

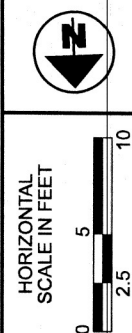

DRIVE DETAILS - S.R. 754
 STA. 205+80.45, RT

(A) = RESIDENTIAL DRIVE BUILD-UP:
 ITEM 441 - 2" ASPHALT CONCRETE SURFACE COURSE,
 TYPE 1, (449), AS PER PLAN (PG70-22M)
 ITEM 304 - 6" AGGREGATE BASE

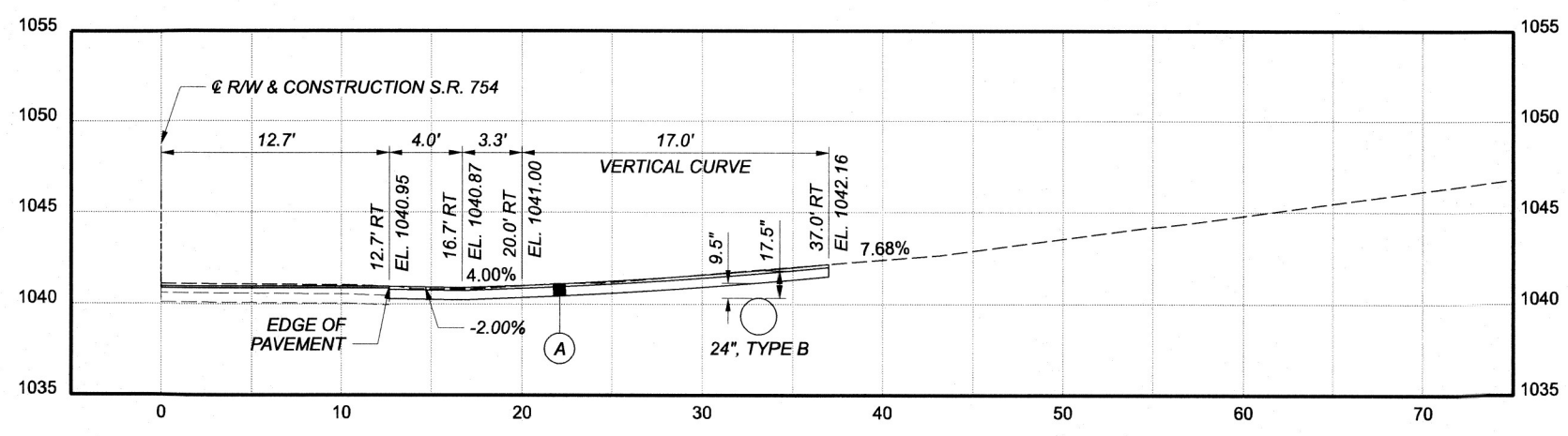

DESIGN AGENCY	B.G.
DESIGNER	JEP
REVIEWER	RG
PROJECT ID	111666
SHEET TOTAL	42 / 93

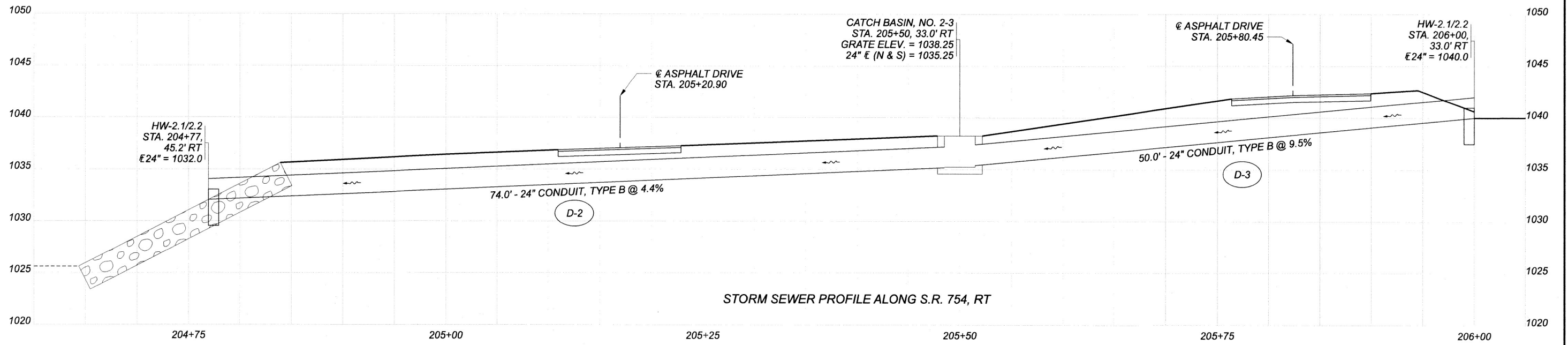

HOL-39/754-11.170.16, TUS-93-10.80

MODEL: XCL-SR93 - Plan [Sheet] PAPER SIZE: 11x17 (in.) DATE: 7/14/2022 TIME: 10:14:44 PM USER: jPerchinske
 P:\Transportation\Work\Sets\11666_HOL-39-118-400-Engineering\Roadway\Sheets\11666_TUS-93-1081.dgn

BENCHMARK DATA	
BM#1	STA. 110+24.27 138.66' LT ELEV. 1052.87 ON UTILITY POLE
BM#2	STA. 112+29.47 25.91' RT ELEV. 1050.90 ON UTILITY POLE

CROSS REFERENCES	
SHEET NO.	DESCRIPTION
45	ESTIMATED QUANTITIES
46-51	CROSS SECTIONS
52	SUPERELEVATION TABLES
53	DRIVE DETAILS
54	INTERSECTION DETAILS
72-77	CULVERT DETAILS

E200 (558)
 BEGIN PROJECT
 STA. 110+25.00
 SLM 10.80

- (A) PROPOSED GRAVEL DRIVE
 STA. 110+54.76, LT
- (B) STA. 111+92.85 @ R/W & CONSTRUCTION S.R. 93 =
 STA. 10+00.00 @ CONSTRUCTION T.R. 436

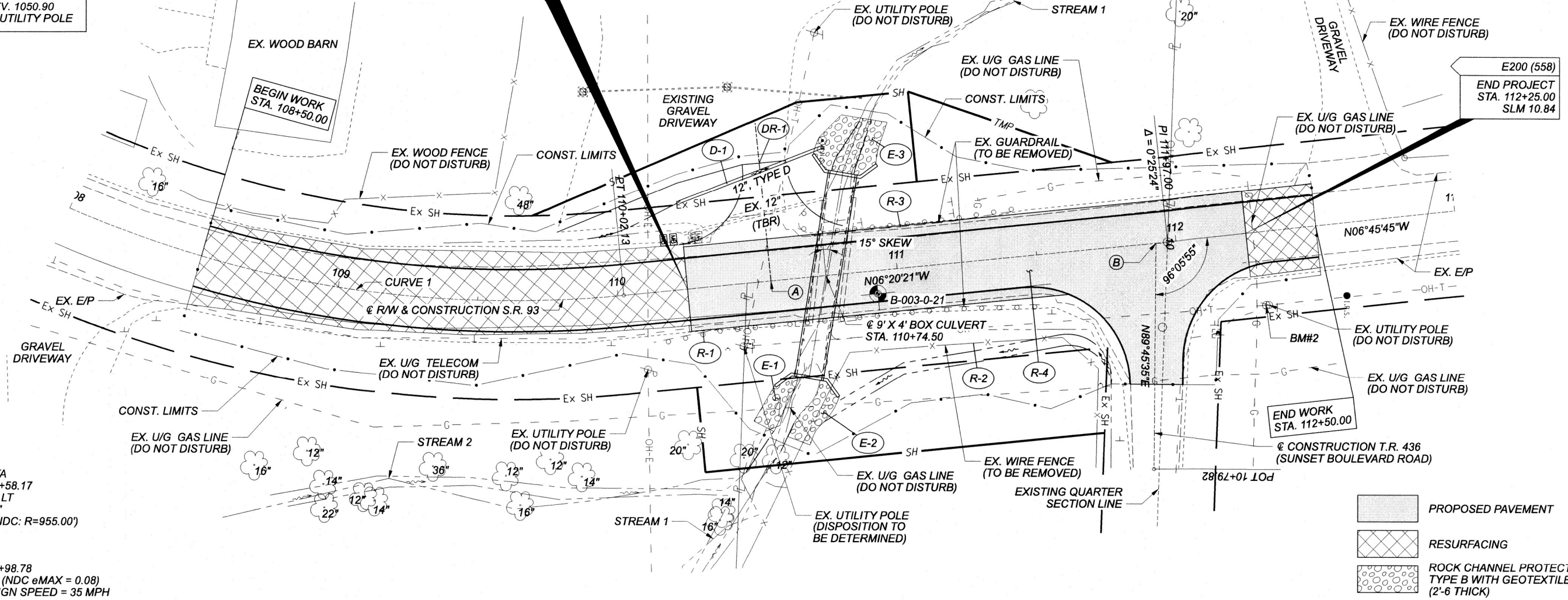

CURVE 1 DATA
 P.I. = Sta. 108+58.17
 $\Delta = 43^\circ 27' 08''$ LT
 $D_c = 14^\circ 19' 26''$
 $R = 400.00'$ (NDC: $R = 955.00'$)
 $T = 159.39'$
 $L = 303.35'$
 $E = 30.59'$
 P.C. STA. 106+98.78
 $e_{MAX} = 0.023$ (NDC $e_{MAX} = 0.08$)
 ACTUAL DESIGN SPEED = 35 MPH

- PROPOSED PAVEMENT
- RESURFACING
- ROCK CHANNEL PROTECTION, TYPE B WITH GEOTEXTILE FABRIC (2'-6" THICK)

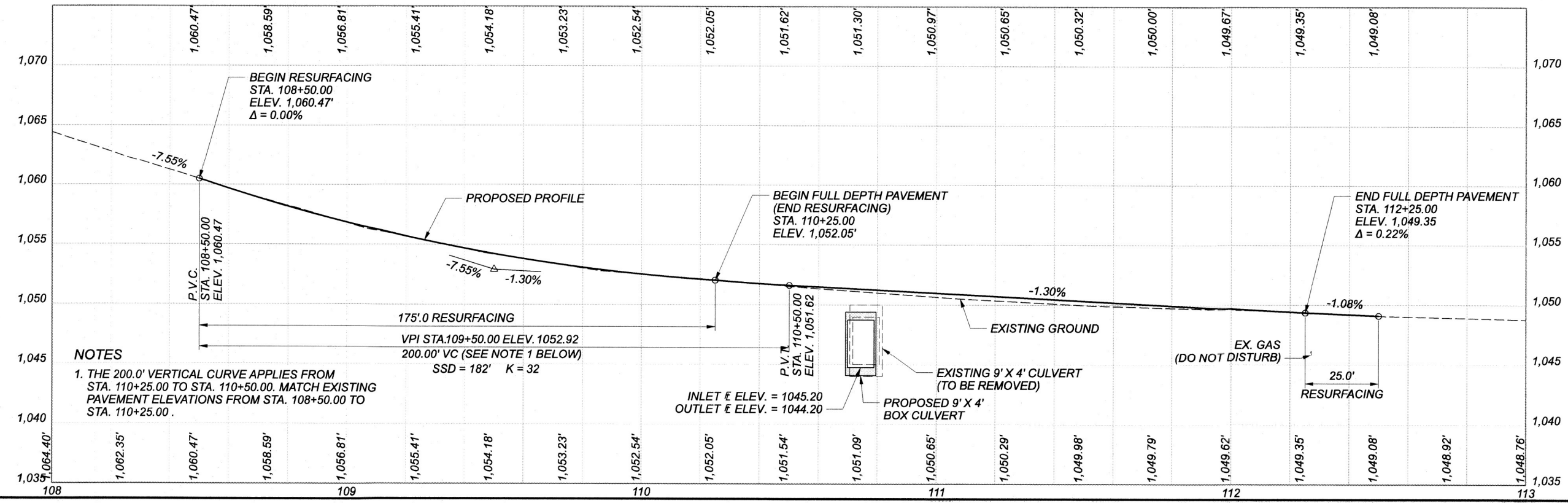

NOTES
 1. THE 200.0' VERTICAL CURVE APPLIES FROM STA. 110+25.00 TO STA. 110+50.00. MATCH EXISTING PAVEMENT ELEVATIONS FROM STA. 108+50.00 TO STA. 110+25.00.

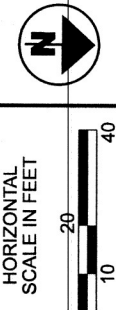

PLAN AND PROFILE - S.R. 93
 STA. 108+00.00 TO STA. 113+00.00

DESIGN AGENCY	
5910 WILCOX PLACE, SUITE C DUBLIN, OHIO 43016	
DESIGNER	JEP
REVIEWER	RG
PROJECT ID	111666
SHEET	TOTAL
44	93

HOL-39/754-11.17/0.16, TUS-93-10.80

MODEL: Sheet PAPER SIZE: 17x11 (in.) DATE: 7/14/2022 TIME: 1:07:53 PM USER: JPerchinske
 P:\Transportation\Work\Sets\111666_HOL_39-11\18400-Engineering\Roadway\Sheets\111666_TUS-93-1081_GQ003.dgn

REF. NO.	SHEET NO.	STATION TO STATION	SIDE	202				204	304	601	611	690
				PAVEMENT REMOVED SQ YD	PIPE REMOVED, 24" AND UNDER FEET	GUARDRAIL REMOVED FEET	FENCE REMOVED FEET	SUBGRADE COMPACTION SQ YD	8" AGGREGATE BASE CU YD	ROCK CHANNEL PROTECTION, TYPE B WITH GEOTEXTILE FABRIC CU YD	12" CONDUIT, TYPED FEET	SPECIAL - MAILBOX REMOVED AND RESET EACH
D-1	44	S.R. 93 110+25 - 110+78	LT		53					55		
DR-1	44	110+54.76	LT	24			81	18			2	
E-1	44	110+44 - 110+61	RT						13			
E-2	44	110+56 - 110+75	RT						16			
E-3	44	110+74 - 110+95	LT						36			
R-1	44	110+11 - 111+49	RT			138						
R-2	44	110+59 - 111+66	RT				160					
R-3	44	110+67 - 111+44	LT			87						
R-4	44	110+25 - 112+25	LT/RT	759								
TOTALS CARRIED TO GENERAL SUMMARY				783	53	225	160	81	18	65	55	2

ESTIMATED QUANTITIES - S.R. 93

DESIGN AGENCY

 www.bgengr.com
 6910 WILCOX PLACE, SUITE C
 DUBLIN, OHIO 43016

DESIGNER
JEP

REVIEWER
RG 6-8-22

PROJECT ID
111666

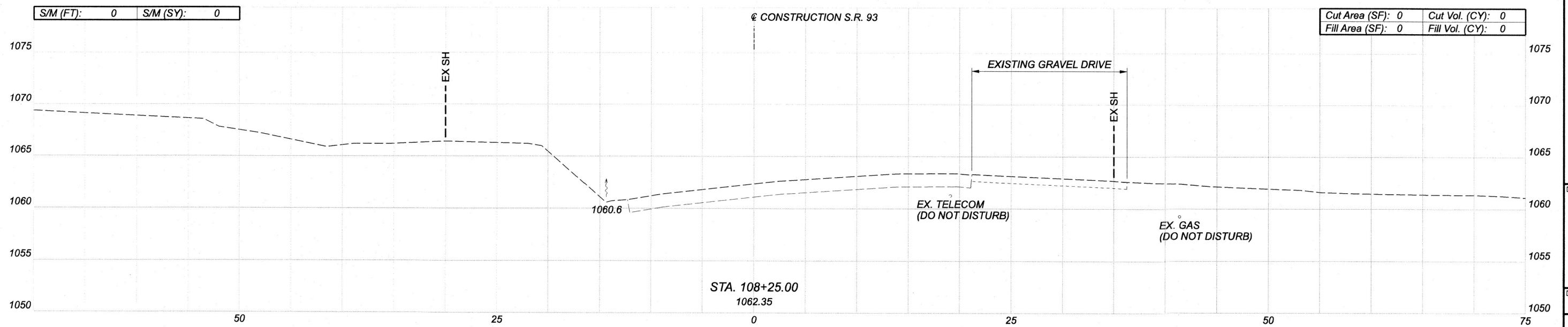
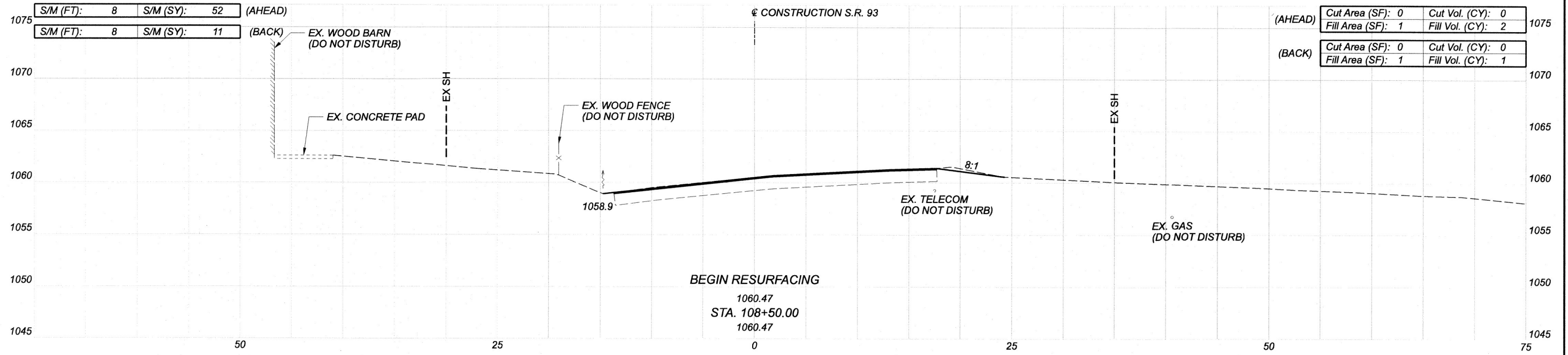
SHEET TOTAL
45 93



Sheet Totals			111666	
Seeding	Cut	Fill	SHEET	TOTAL
63	0	3	46	93

DESIGN AGENCY

 DESIGNER
 JEP
 REVIEWER
 RG 6-8-22
 PROJECT ID
 111666

CROSS SECTIONS - S.R. 93
 STA. 108+25.00 TO STA. 108+50.00

5910 WILCOX PLACE, SUITE C
 DUBLIN, OHIO 43016

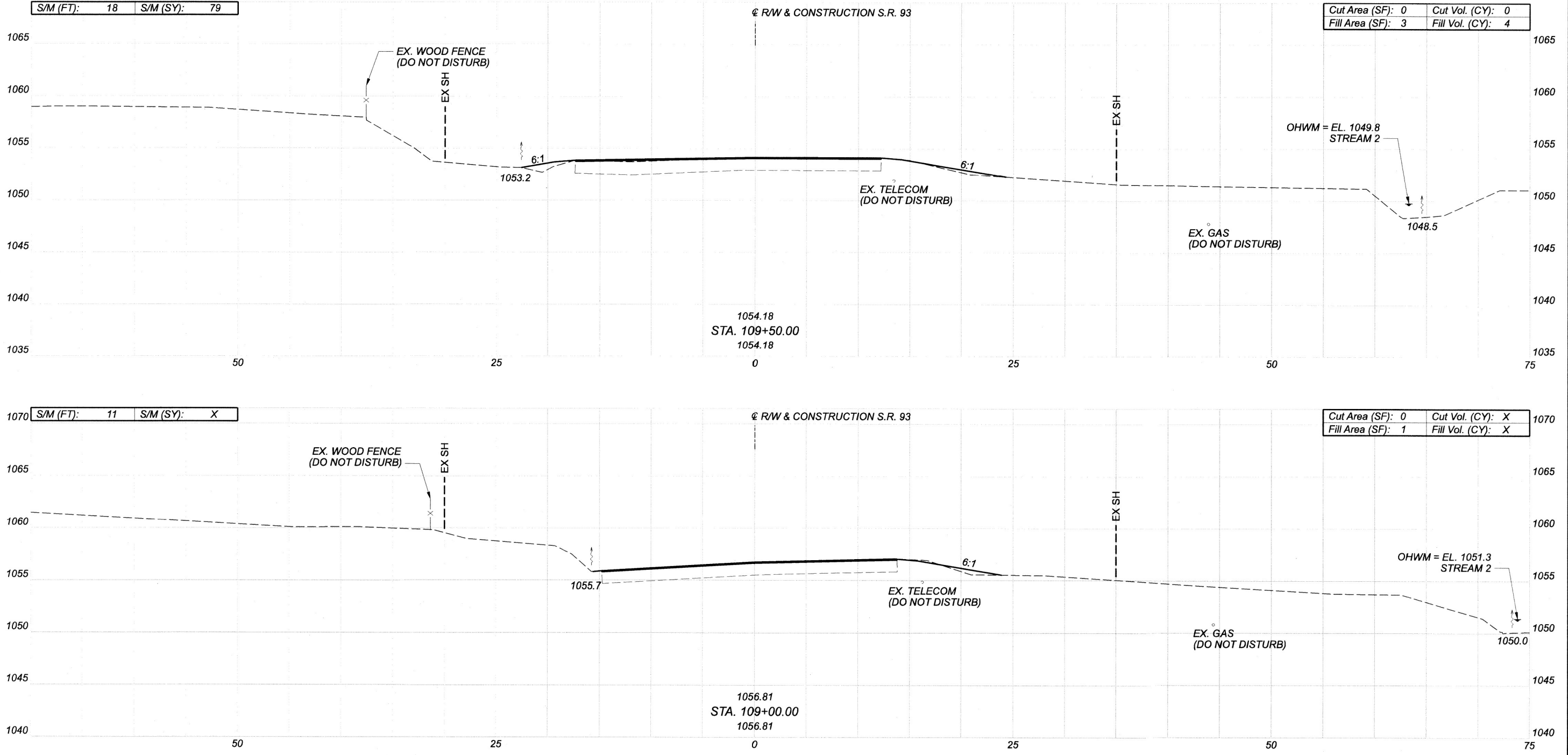

S/M (FT):	18	S/M (SY):	79
-----------	----	-----------	----

Cut Area (SF):	0	Cut Vol. (CY):	0
Fill Area (SF):	3	Fill Vol. (CY):	4

S/M (FT):	11	S/M (SY):	X
-----------	----	-----------	---

Cut Area (SF):	0	Cut Vol. (CY):	X
Fill Area (SF):	1	Fill Vol. (CY):	X

Sheet Totals			111666	
Seeding	Cut	Fill	SHEET	TOTAL
79	0	4	47	93

CROSS SECTIONS - S.R. 93
 STA. 109+00.00 TO STA. 109+50.00

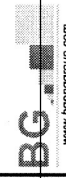
DESIGN AGENCY

 www.bgggroup.com
 5910 WILCOX PLACE, SUITE C
 DUBLIN, OHIO 43016

DESIGNER
 JEP

REVIEWER
 RG 6-8-22

PROJECT ID
 111666

HOL-39/754-11.17/0.16, TUS-93-10.80

MODEL: XCL-SR93 - 110+00.00 [Sheet1] PAPER SIZE: 17x11 (in.) DATE: 7/14/2022 TIME: 10:08:24 PM USER: JPerchinske
 P: Transportation\Work\Sets\111666_HOL-39-118\400-Engineering\Roadway\Sheets\111666_TUS-93-1081_XS303.dgn

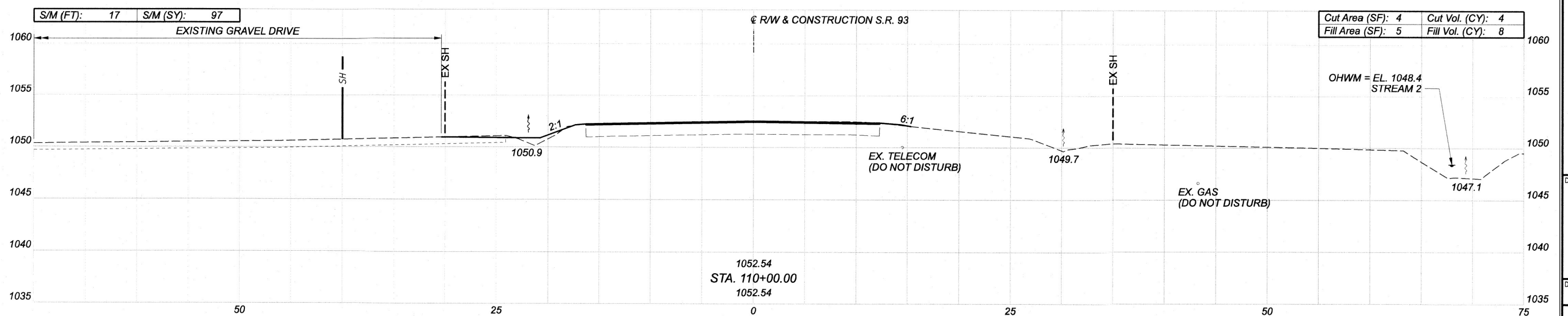
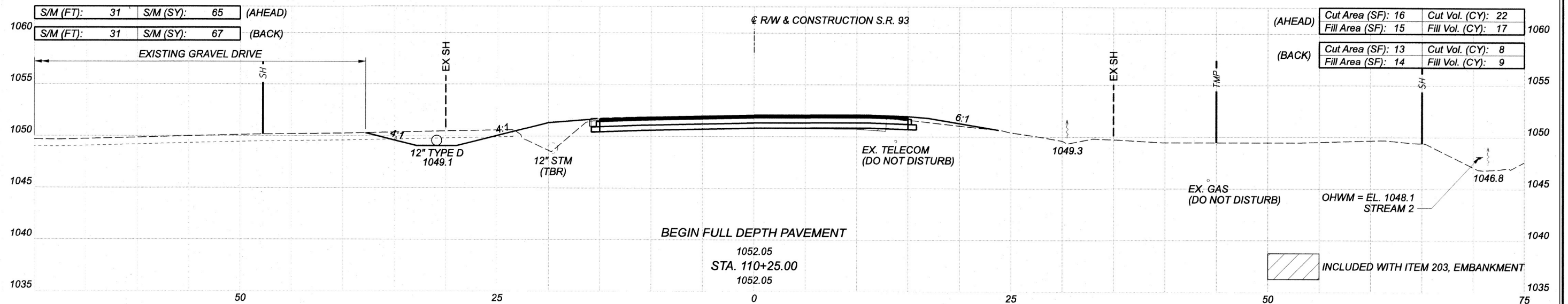
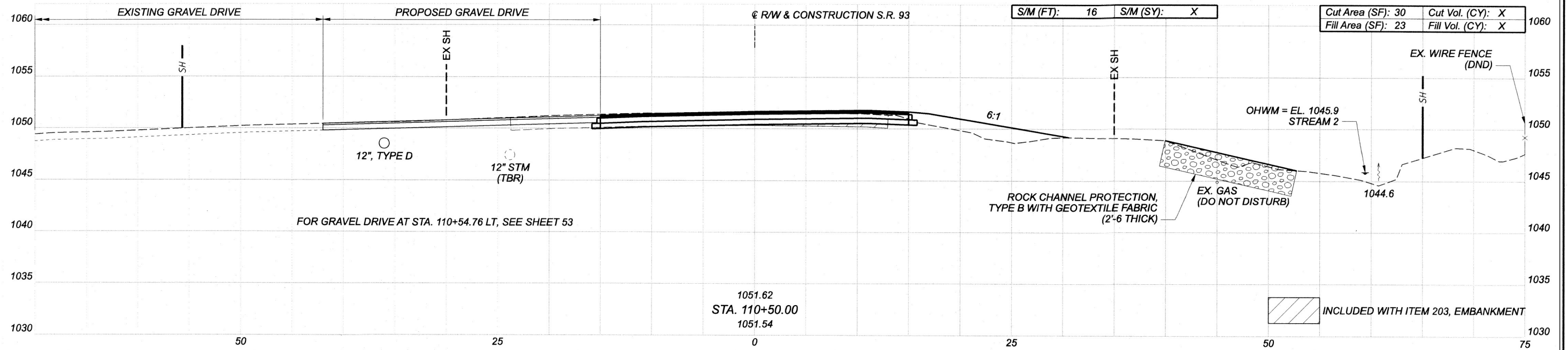

CROSS SECTIONS - S.R. 93
 STA. 110+00.00 TO STA. 110+50.00

Sheet Totals			111666	
Seeding	Cut	Fill	SHEET	TOTAL
229	34	34	48	93

DESIGN AGENCY

 www.bgggroup.com
 5910 WILCOX PLACE, SUITE C
 DUBLIN, OHIO 43016

DESIGNER
 JEP

REVIEWER
 JEP 6-8-22

PROJECT ID
 111666

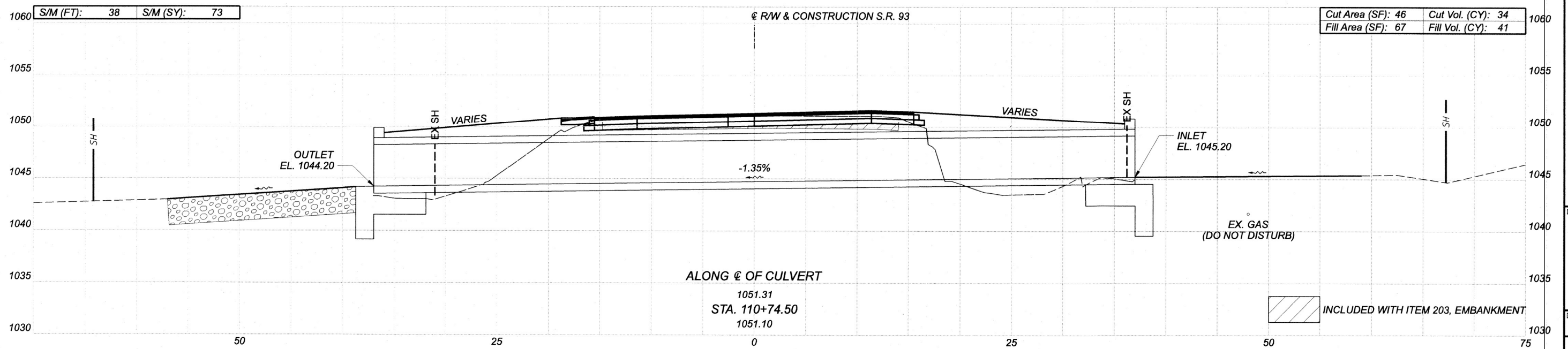
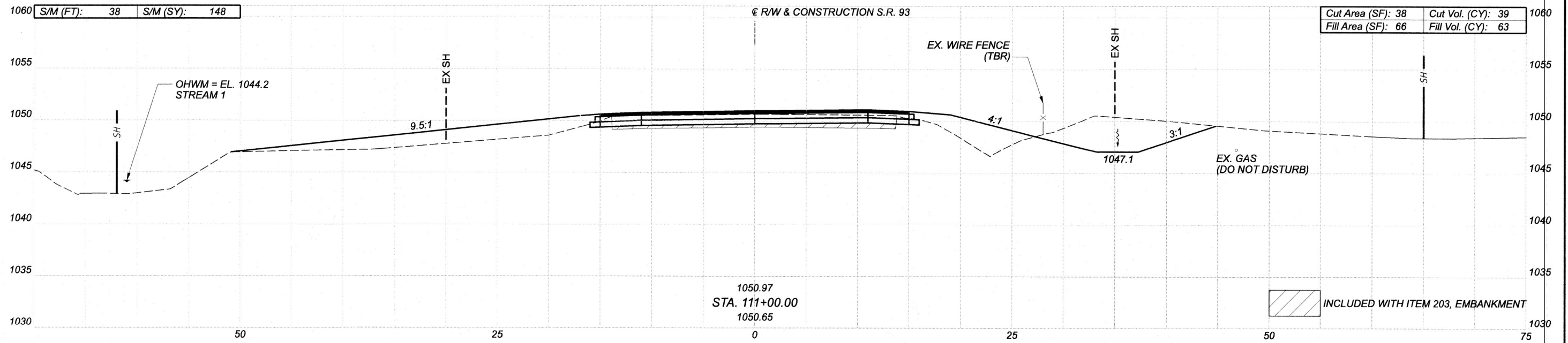

Sheet Totals			PROJECT ID	
Seeding	Cut	Fill	SHEET	TOTAL
221	73	104	49	93

DESIGN AGENCY
BG
 www.bggroup.com
 5910 WILCOX PLACE, SUITE C
 DUBLIN, OHIO 43016

DESIGNER
 JEP

REVIEWER
 RG 6-8-22

PROJECT ID
 111666

CROSS SECTIONS - S.R. 93
 STA. 110+74.50 TO STA. 111+00.00

HOL-391754-11.17.0.16, TUS-93-10.80

MODEL: XCL-SR93 - 111+50.00 [Sheet] PAPER SIZE: 17x11(in.) DATE: 7/14/2022 TIME: 10:08:28 PM USER: JPerchinske
 P:\Transportation\Worksets\111666_HOL-391754-11.17.0.16-Engineering\Roadway\Sheet\111666_TUS-93-10.80_XS303.dgn

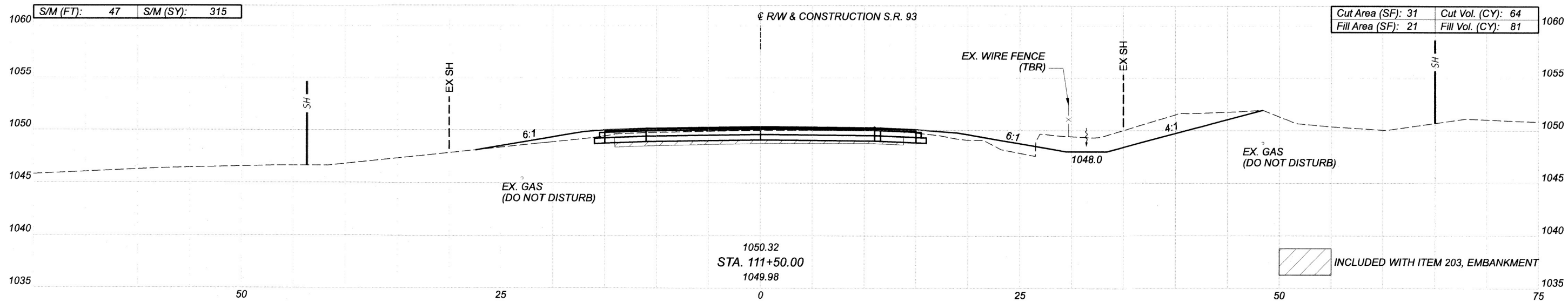
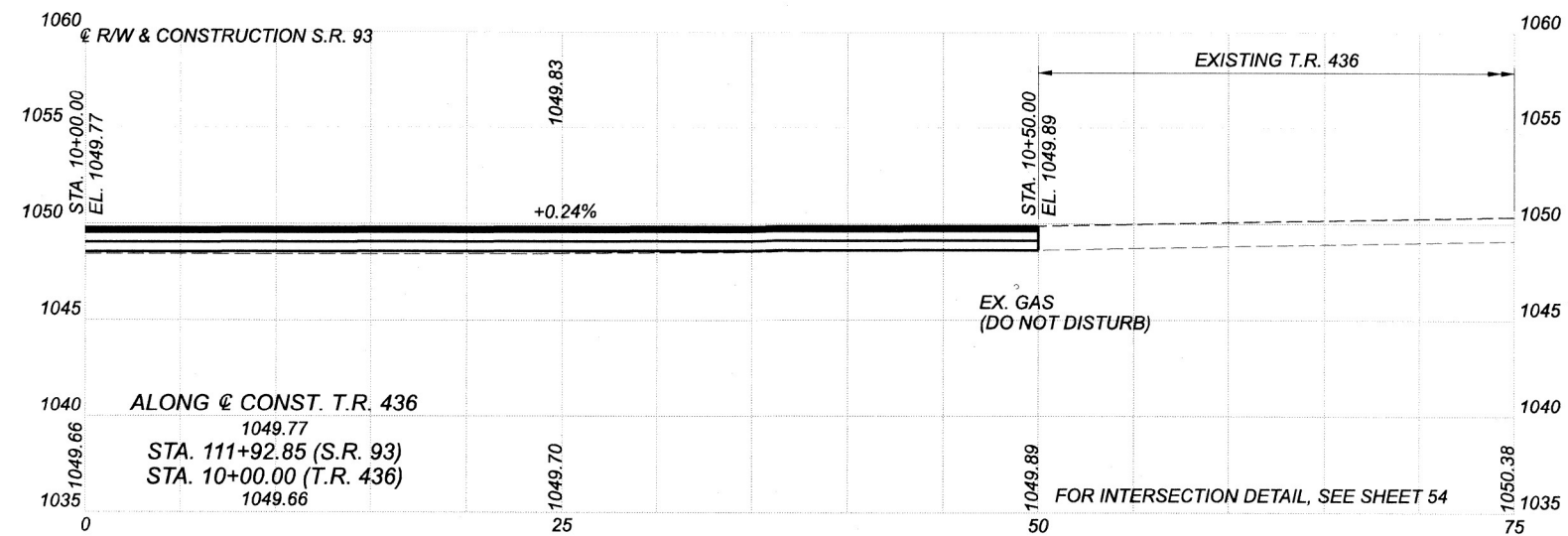
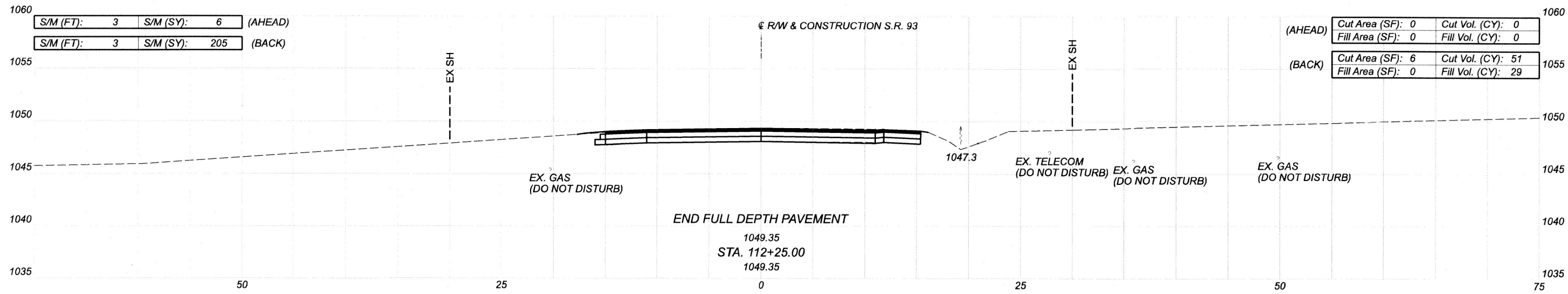

Sheet Totals			111666	
Seeding	Cut	Fill	SHEET	TOTAL
526	115	110	50	93

DESIGN AGENCY	B.G.
DESIGNER	JEP
REVIEWER	RG
DATE	6-8-22
PROJECT ID	111666

CROSS SECTIONS - S.R. 93
 STA. 111+50.00 TO STA. 112+25.00

www.bgroup.com
 5910 WILCOX PLACE, SUITE C
 DUBLIN, OHIO 43015

CROSS SECTION TOTALS	
S/M (SY):	1118*
CUT (CY):	222**
FILL (SY):	255**

* = TOTALS CARRIED TO THE GENERAL NOTES
 ** = TOTALS CARRIED TO THE GENERAL SUMMARY

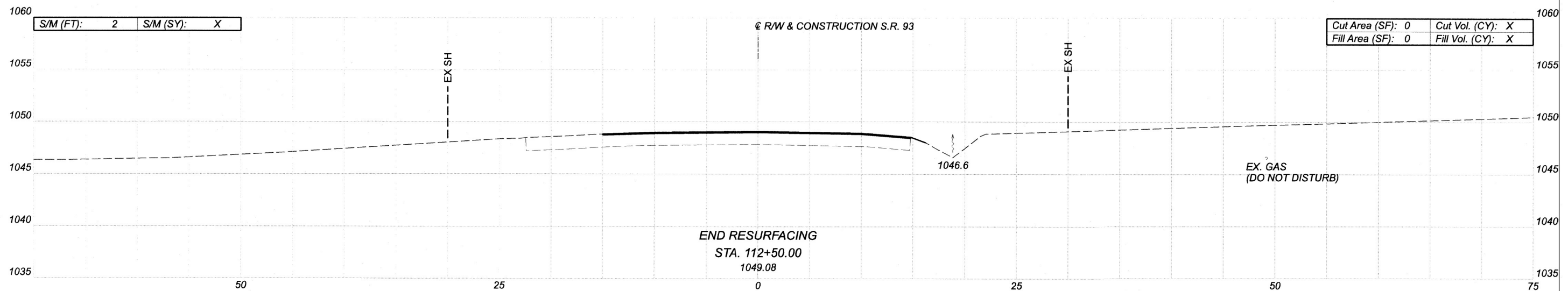
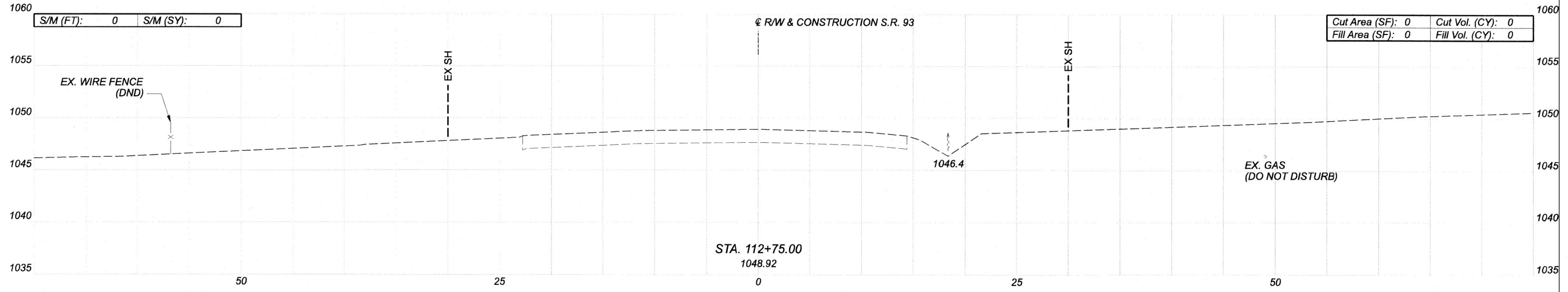

CROSS SECTIONS - S.R. 93
 STA. 112+50.00 TO STA. 112+75.00

DESIGN AGENCY

 www.bgroup.com
 5910 WILCOX PLACE, SUITE C
 DUBLIN, OHIO 43016

DESIGNER
 JEP

REVIEWER
 RG 6-8-22

PROJECT ID
 111666

Sheet Totals			PROJECT ID	
Seeding	Cut	Fill	SHEET	TOTAL
8	1	0	51	93

(HOL-39-11.17) SUPERELEVATION TABLE												
PI STA. 88+45.64, Dc = 2° 16' 16"												
LEFT SIDE					CENTERLINE CONTROL		RIGHT SIDE					
EDGE ELEVATION	TRANSITION RATE	ELEVATION CORRECTION	CROSS SLOPE	WIDTH	S.R. STATION	PROFILE GRADE	WIDTH	CROSS SLOPE	ELEVATION CORRECTION	TRANSITION RATE	EDGE ELEVATION	REMARKS
1101.70		-0.72	-0.057	12.60	89+00.00	1102.42	11.00	0.024	0.26		1102.68	MATCH EX.
1100.52		-0.83	-0.064	12.90	89+25.00	1101.35	11.00	0.010	0.11		1101.46	
1099.88		-0.61	-0.046	13.20	89+50.00	1100.49	11.00	0.046	0.51		1101.00	
1099.12		-0.58	-0.046	12.60	89+75.00	1099.70	11.50	0.046	0.53		1100.23	
1098.49		-0.55	-0.046	12.00	90+00.00	1099.04	12.00	0.046	0.55		1099.60	
1098.08		-0.55	-0.046	12.00	90+19.57	1098.63	12.00	0.046	0.55		1099.18	F.S.
1098.00	213:1	-0.53	-0.044	12.00	90+25.00	1098.53	12.00	0.044	0.53	213:1	1099.05	
1097.74		-0.41	-0.034	12.00	90+50.00	1098.15	12.00	0.034	0.41		1098.56	
1097.70		-0.38	-0.032	12.00	90+56.01	1098.08	12.00	0.032	0.38		1098.46	P.T.
1097.61		-0.29	-0.024	12.00	90+75.00	1097.90	12.00	0.024	0.29		1098.20	
1097.61		-0.19	-0.016	12.00	90+96.25	1097.81	12.00	0.016	0.19		1098.00	
1097.61		-0.19	-0.016	12.00	91+00.00	1097.80	12.00	0.015	0.17		1097.97	
1097.64		-0.19	-0.016	12.00	91+25.00	1097.83	12.00	0.005	0.06		1097.89	
1097.70		-0.19	-0.016	12.00	91+37.15	1097.89	12.00	0.000	0.00		1097.89	
1097.81	-0.19	-0.016	12.00	91+50.00	1098.00	12.00	-0.005	-0.06	1097.94			
1098.16	-0.19	-0.016	12.00	91+78.04	1098.35	12.00	-0.016	-0.19	1098.16			
1098.11	-0.19	-0.016	12.00	91+75.00	1098.30	12.00	-0.016	-0.19	1098.11			
1098.56	-0.19	-0.016	12.00	92+00.00	1098.75	12.00	-0.016	-0.19	1098.56			
1099.14	-0.19	-0.016	12.00	92+25.00	1099.33	12.00	-0.016	-0.19	1099.14			
1099.85	-0.19	-0.016	12.00	92+50.00	1100.04	12.00	-0.016	-0.19	1099.85			

(TUS-93-10.80) SUPERELEVATION TABLE												
PI STA. 108+58.17, Dc = 14° 19' 26"												
LEFT SIDE					CENTERLINE CONTROL		RIGHT SIDE					
EDGE ELEVATION	TRANSITION RATE	ELEVATION CORRECTION	CROSS SLOPE	WIDTH	S.R. STATION	PROFILE GRADE	WIDTH	CROSS SLOPE	ELEVATION CORRECTION	TRANSITION RATE	EDGE ELEVATION	REMARKS
1051.80		-0.25	-0.023	11.00	110+25.00	1052.05	11.00	0.003	0.03		1052.08	MATCH EX.
1051.37		-0.25	-0.023	11.00	110+50.00	1051.62	11.00	0.013	0.14		1051.76	
1051.04		-0.25	-0.023	11.00	110+75.00	1051.30	11.00	0.023	0.25		1051.55	F.S.◇
1050.91		-0.18	-0.016	11.00	110+90.30	1051.10	11.00	0.016	0.18	213:1	1051.28	
1050.79		-0.18	-0.016	11.00	111+00.00	1050.97	11.00	0.012	0.14		1051.11	
1050.47		-0.18	-0.016	11.00	111+25.00	1050.65	11.00	0.002	0.02		1050.66	
1050.42		-0.18	-0.016	11.00	111+28.89	1050.59	11.00	0.000	0.00		1050.59	
1050.14		-0.18	-0.016	11.00	111+50.00	1050.32	11.00	-0.009	-0.10		1050.22	
1049.95		-0.18	-0.016	11.00	111+65.28	1050.12	11.00	-0.016	-0.17		1049.95	
1049.82		-0.18	-0.016	11.00	111+75.00	1050.00	11.00	-0.016	-0.18	1049.82		

◇ NDC = 0.08
 ACTUAL DESIGN SPEED = <25MPH



DESIGNER	JEP
REVIEWER	RG 6-8-22
PROJECT ID	111666
SHEET	TOTAL
52	93

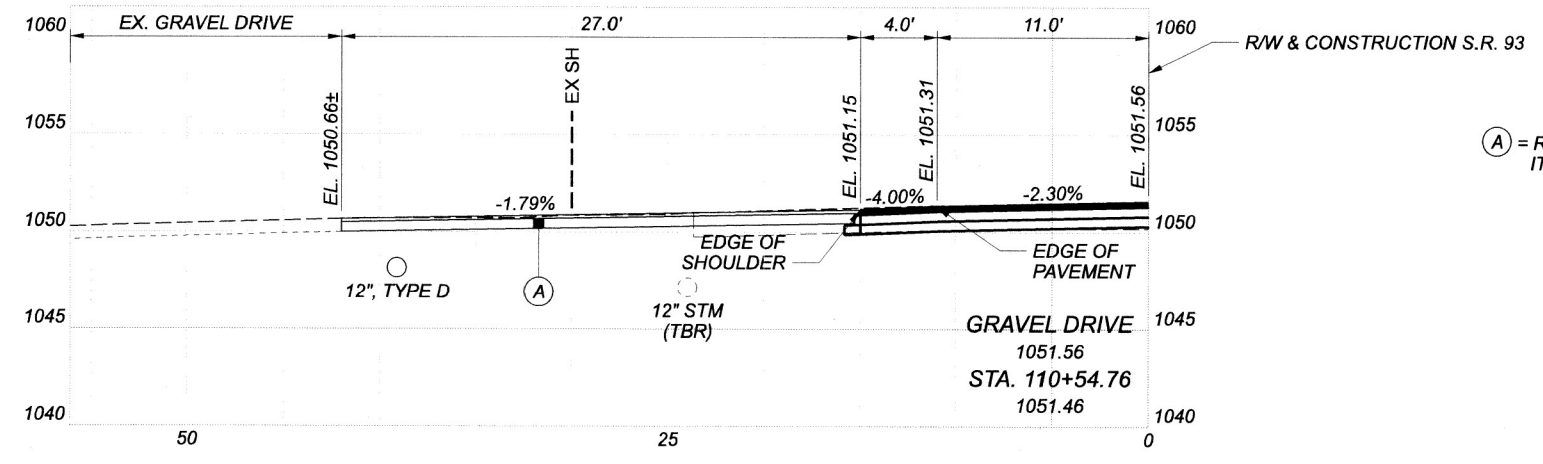
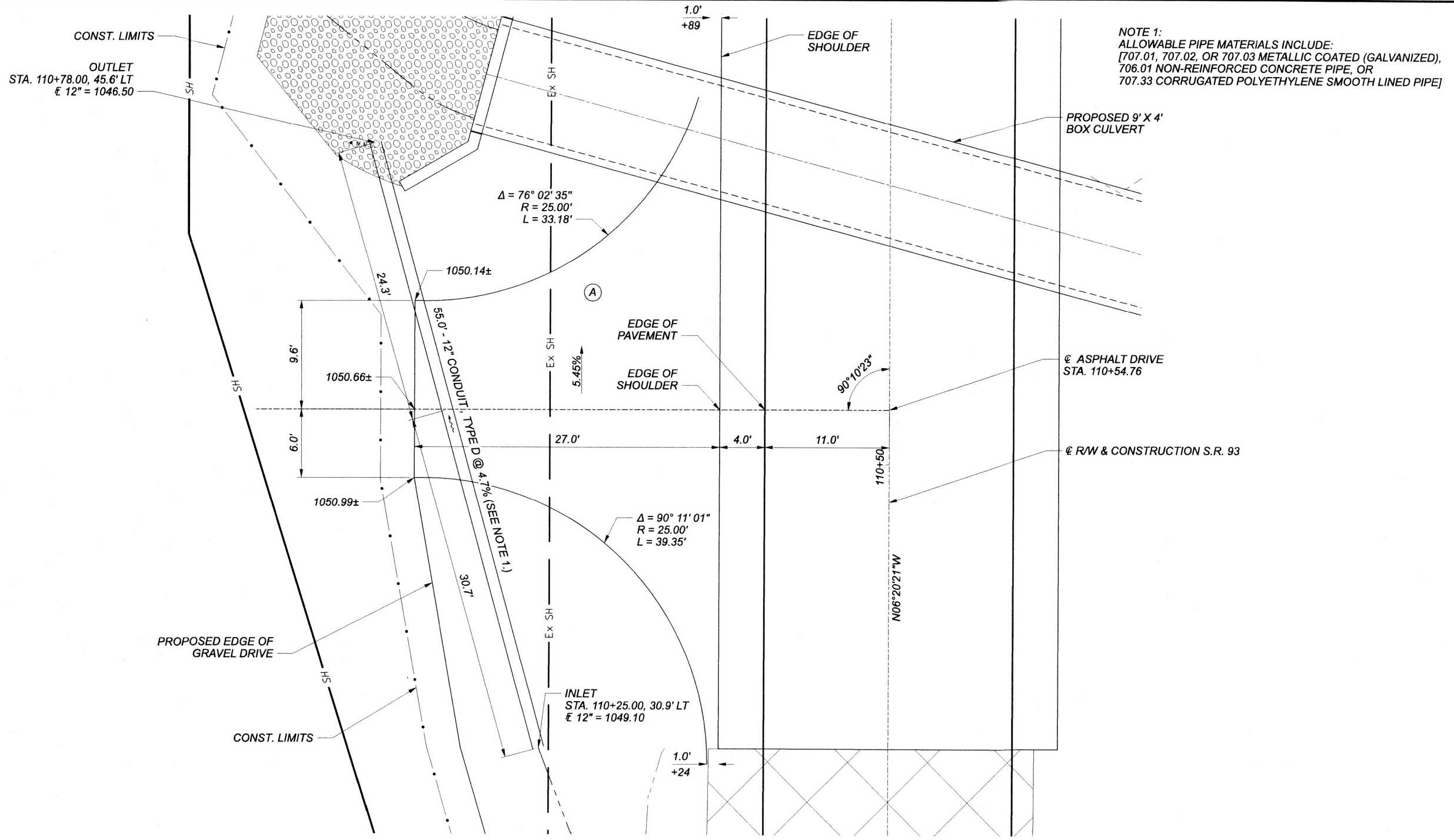

(A) = RESIDENTIAL DRIVE BUILD-UP:
ITEM 304 - 8" AGGREGATE BASE

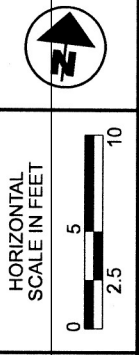

DRIVE DETAILS - S.R. 93
STA 110+54.76

DESIGN AGENCY	
BG GROUP www.bgroup.com 5810 WILCOX PLACE, SUITE C DUBLIN, OHIO 43016	
DESIGNER	JEP
REVIEWER	RG
PROJECT ID	111666
SHEET	53
TOTAL	93

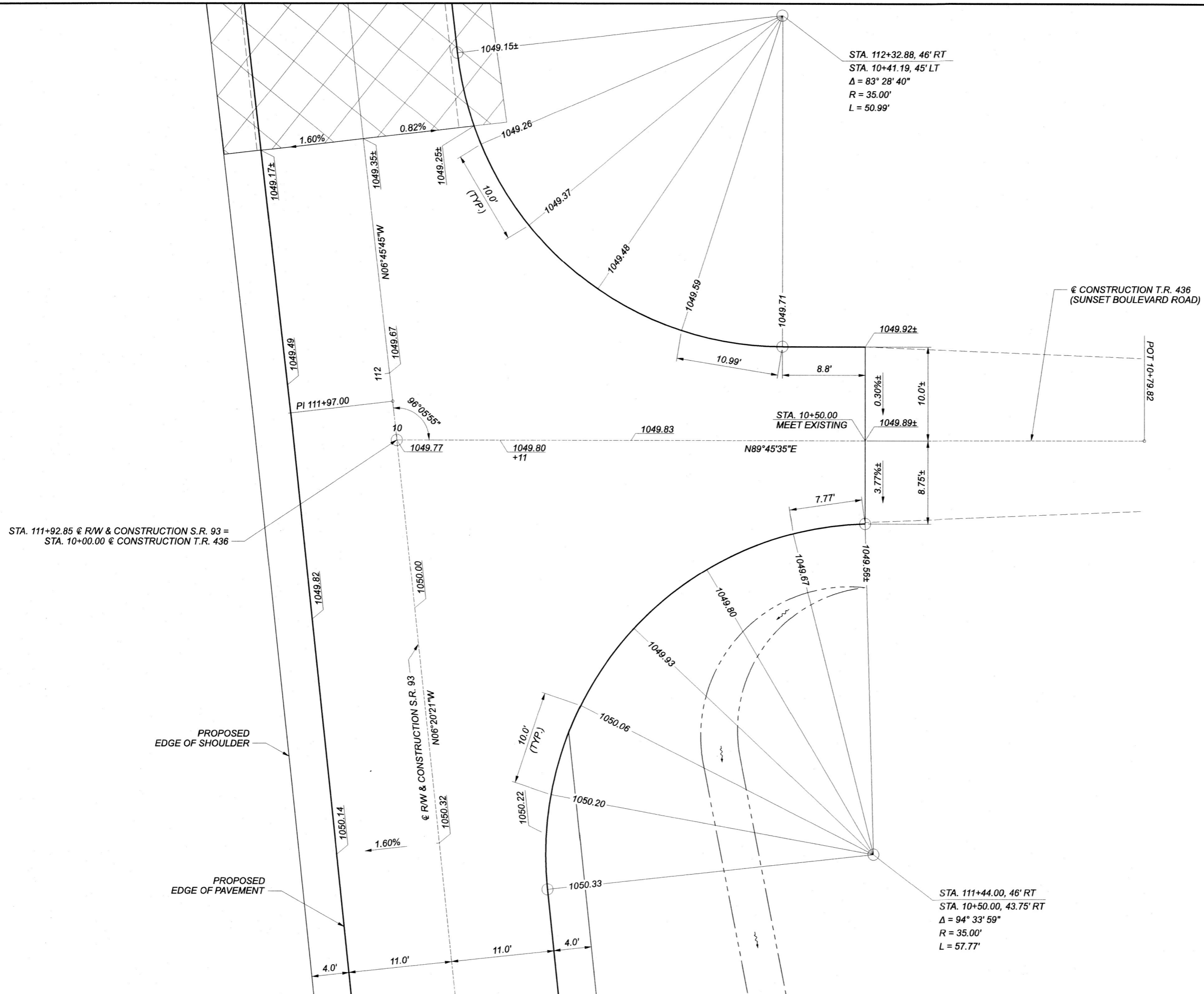

INTERSECTION DETAIL
 S.R. 93 & T.R. 436

DESIGN AGENCY	
 6910 MILCOY PLACE, SUITE C DUBLIN, OHIO 43016	
DESIGNER	JEP
REVIEWER	RG
PROJECT ID	111666
SHEET	TOTAL
54	93

HOL-39/754-11.170.16, TUS-93-10.80

MODEL: Sheet PAPER SIZE: ITX1(11.0) DATE: 7/14/2022 TIME: 10:06 PM USER: JPerchinske
 P:\Transportation\Worksets\11666_HOL-39-118\400-Engineering\Traffic\Sheets\11666_HOL-39-118_TP001.dgn

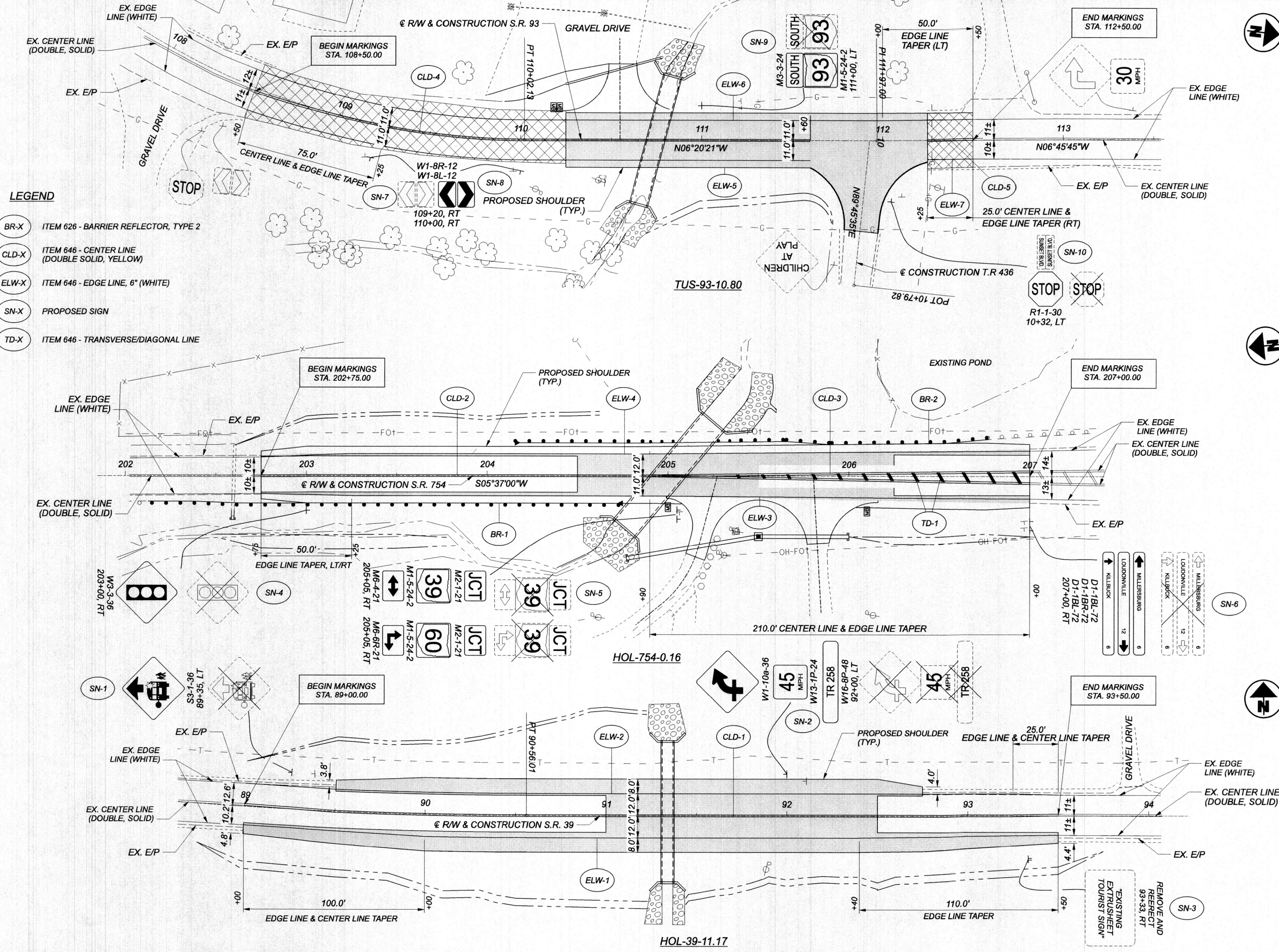

- LEGEND**
- BR-X ITEM 626 - BARRIER REFLECTOR, TYPE 2
 - CLD-X ITEM 646 - CENTER LINE (DOUBLE SOLID, YELLOW)
 - ELW-X ITEM 646 - EDGE LINE, 6" (WHITE)
 - SN-X PROPOSED SIGN
 - TD-X ITEM 646 - TRANSVERSE/DIAGONAL LINE

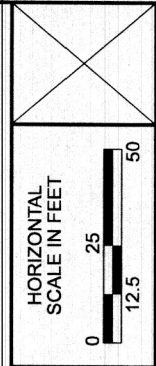

TRAFFIC CONTROL
 HOL-39, HOL-754, AND TUS-93

DESIGN AGENCY	
6510 WILCOX PLACE, SUITE C DUBLIN, OHIO 43016	
DESIGNER	JEP
REVIEWER	RG
PROJECT ID	111666
SHEET TOTAL	55 / 93

SHEET NO.	REFERENCE NO.	STATION TO STATION			SIDE	CODE	SIZE (INCHES)	621		626		630					646				
								RPM (YELLOW/YELLOW)	RAISED PAVEMENT MARKER REMOVED	BARRIER REFLECTOR, TYPE 2 (BI-DIRECTIONAL)	GROUND MOUNTED SUPPORT, NO. 2 POST	GROUND MOUNTED SUPPORT, NO. 3 POST	SIGN POST REFLECTOR	SIGN, FLAT SHEET	REMOVAL OF GROUND MOUNTED SIGN AND DISPOSAL	REMOVAL OF GROUND MOUNTED SIGN AND REEFECTION	REMOVAL OF GROUND MOUNTED POST SUPPORT AND DISPOSAL	EDGE LINE, 6"	CENTER LINE	TRANSVERSE/DIAGONAL LINE	
							EACH	EACH	EACH	FEET	FEET	EACH	SQ FT	EACH	EACH	EACH	MILE	MILE	FEET		
S.R. 39																					
55	CLD-1	89+00	-	93+50	CL		7	7										0.09			
55	ELW-1	89+00	-	93+50	RT													0.09			
55	ELW-2	89+00	-	93+50	LT													0.09			
S.R. 754																					
55	SN-1	89+35			LT	S3-1-36 (36X36)					12.0	1	9.0	1							
55	SN-2	92+00			LT	W1-10a-36 (36X36) W13-1P-24 (24X24) W16-8P-48 (12X48)					13.7		9.0	3							
55	SN-3	93+33			RT						12.0/12.0				1						
S.R. 93																					
55	BR-1	202+12	-	204+75	RT							7									
55	BR-2	204+15	-	206+78	LT							7									
55	CLD-2	202+75	-	207+00	CL		7	7												0.08	
55	CLD-3	204+90	-	207+00	CL		4	4												0.04	
55	ELW-3	202+75	-	207+00	RT															0.08	
55	ELW-4	202+75	-	207+00	LT															0.08	
55	TD-1	204+90	-	207+00	LT/RT															54	
55	SN-4	203+00			RT	W3-3-36 (36X36)					12.0	1	9.0	1							
55	SN-5	205+05			RT	M2-1-21 (21X15) M1-5-24-2 (24X24) M6-4-21 (21X15)					12.7		2.2	3							
						M2-1-21 (21X15) M1-5-24-2 (24X24) M6-6R-21 (21X15)					12.7		2.2	3							
55	SN-6	207+00			RT	D1-1BL-72 (72X12) D1-1BR-72 (72X12) D1-1BL-72 (72X12)					11.2/11.2		6.0	3							
55	CLD-4	108+50	-	111+60	CL		11	11												0.06	
55	CLD-5	112+25	-	112+50	CL		1	1												0.01	
55	ELW-5	108+50	-	111+60	RT															0.06	
55	ELW-6	108+50	-	112+50	LT															0.08	
55	ELW-7	112+25	-	112+50	RT															0.01	
55	SN-7	109+20			RT	W1-8R-12 (12X24) W1-8L-12 (12X24)				9.5		2	2.0	2							
55	SN-8	110+00			RT	W1-8R-12 (12X24) W1-8L-12 (12X24)				9.5		2	2.0	2							
55	SN-9	111+00			LT	M3-3-24 (24X12) M1-5-24-2 (24X24)					12.1		2.0	2							
55	SN-10	10+32			LT	R1-1-30 (30X30)				11.5		1	6.3	1	1						
TOTALS CARRIED TO GENERAL SUMMARY							30	30	14	30.5	121.6	7	90.0	21	2	13		0.49	0.28	54	

TRAFFIC CONTROL SUBSUMMARY

DESIGN AGENCY

 www.bgggroup.com
 5810 WILCOX PLACE, SUITE C
 DUBLIN, OHIO 43016

DESIGNER
 JEP

REVIEWER
 RG 7-14-22

PROJECT ID
 111666

SHEET TOTAL
 56 93

HOL-39754-11.170-16, TUS-93-10.80

MODEL SHEET PAPER SIZE: 17x11 (in.) DATE: 7/14/2022 TIME: 1:10:33 PM USER: JPerchinske
 P:\Transportation\Works\111666_HOL_39-1118400-Engineering\Structures\CFN_1977350\Sheet111666.dgn

HYDRAULIC DATA

DRAINAGE AREA: 0.07 SQ. MI.
 EXISTING WATERWAY OPENING: 16.00 SF
 PROPOSED WATERWAY OPENING: 24.00 SF
 ORDINARY HIGH WATER MARK: 1091.25
 DESIGN SERVICE LIFE: 75 YEARS
 Ph: 6.7
 ABRASION LEVEL: NON-ABRASIVE SITE

Q ₂₅ = 90 CFS	Q ₁₀₀ = 144 CFS
V ₂₅ = 12.34 FPS	V ₁₀₀ = 13.76 FPS
H ₂₅ = 1092.03	H ₁₀₀ = 1093.23

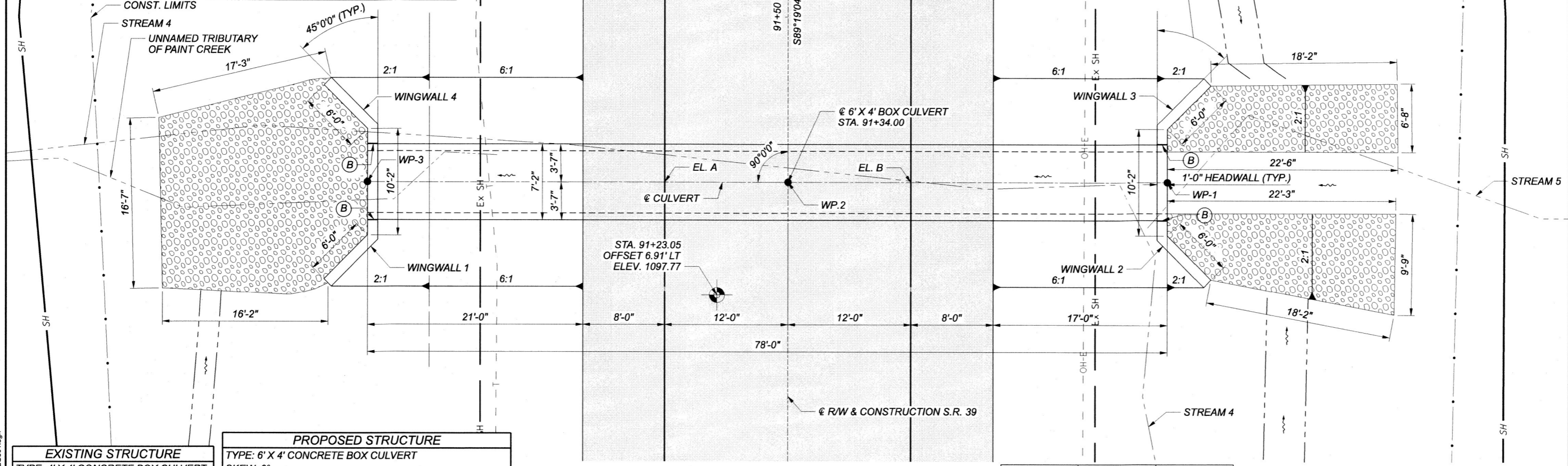

EXISTING STRUCTURE

TYPE: 4' X 4' CONCRETE BOX CULVERT
 SKEW: 0°
 ALIGNMENT: TANGENT
 CFN: 1800562
 CONDITION: POOR
 DISPOSITION: TO BE REPLACED

PROPOSED STRUCTURE

TYPE: 6' X 4' CONCRETE BOX CULVERT
 SKEW: 0°
 ALIGNMENT: TANGENT
 ROADWAY WIDTH: 24'-0" PAVED SHLDR/SHLDR
 CROWN: SUPERELEVATION VARIES
 LOADING: HL-93 AND 60 PSF FUTURE WEARING SURFACE
 DESIGN SERVICE LIFE: 75 YEAR
 CFN: 1977350

WORK POINT	STATION	OFFSITE
WP-1	91+34.00	37' RT
WP-2	91+34.00	0
WP-3	91+34.00	41' LT

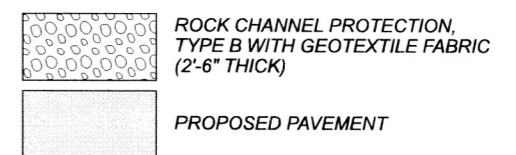

- (A) SEE SHEET 2 FOR TYPICAL PAVEMENT BUILD-UP
- (B) 1" PEJF

PLAN

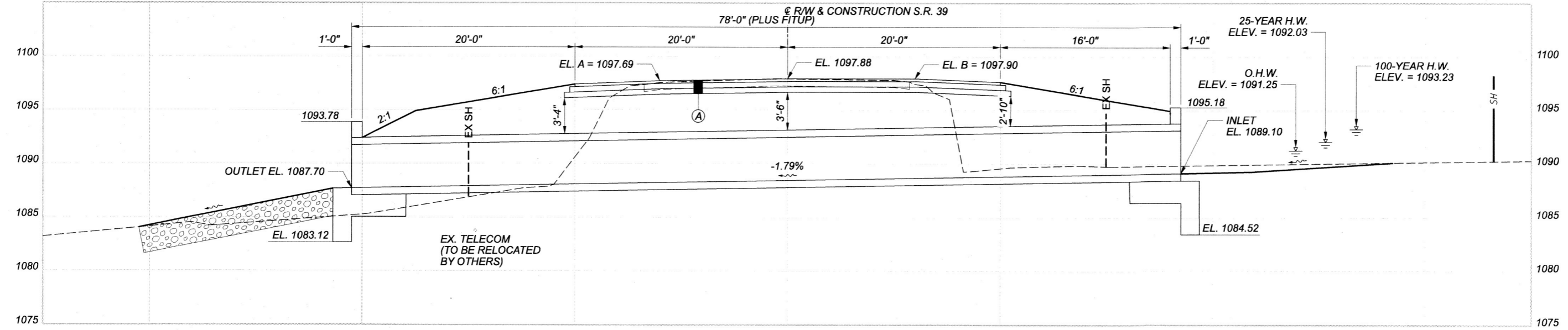

PROFILE ALONG @ CULVERT

CULVERT PLAN AND PROFILE
 CULVERT NO. HOL-00039-11.176
 S.R. 39 OVER UNNAMED TRIBUTARY OF PAINT CREEK

CFN	1977350
DESIGN AGENCY	B.G. Engineering Group, Inc. 5910 WILCOX PLACE, SUITE C DUBLIN, OHIO 43016
DESIGNER	JEP
CHECKER	RG
REVIEWER	
GTB	7-14-22
PROJECT ID	111666
SUBSET	TOTAL
1	8
SHEET	TOTAL
57	93

GENERAL NOTES:

DESIGN SPECIFICATION:

THE STRUCTURE CONFORMS TO "LRFD BRIDGE DESIGN SPECIFICATIONS" ADOPTED BY THE AMERICAN ASSOCIATION OF STATE HIGHWAY AND TRANSPORTATION OFFICIALS, 9TH EDITION, 2020 AND THE ODOT BRIDGE DESIGN MANUAL, 2020

DESIGN DATA:

THE FOLLOWING DESIGN DATA IS ASSUMED:

INTERNAL ANGLE OF FRICTION, (ϕ_{bf}) = 30°
 TOTAL UNIT WEIGHT OF BACKFILL SOIL = 120 PCF
 INTERNAL ANGLE OF FRICTION (DRAINED), FOUNDATION SOIL, ϕ_f = 28°
 UNDRAINED SHEAR STRENGTH (COHESIVE), FOUNDATION SOIL, S_{uf} = 1500 PSF
 UNIT WEIGHT OF CONCRETE = 150 PCF
 SLOPE OF BACKFILL = 2:1 (TYPE A & B HEADWALLS)
 HEIGHT OF LIVE LOAD SURCHARGE = 2 FT (TYPE C HEADWALLS)

CONCRETE CLASS QC1 - REQUIRED COMPRESSIVE STRENGTH 4000 PSI (FOOTING, WINGWALL AND FORESLOPE WALL)

REINFORCING STEEL - ASTM A615, A616, OR A617
 GRADE 60 MINIMUM YIELD STRENGTH 60,000 PSI (ALL REINFORCING SHALL BE EPOXY COATED)

BASED ON THE ASSUMED DESIGN DATA, THE WINGWALLS ACHIEVE FACTORED BEARING RESISTANCES THAT ARE GREATER THAN THEIR RESPECTIVE BEARING PRESSURES. IF A BACKFILL MATERIAL WITH A HIGHER INTERNAL ANGLE OF FRICTION OR A LIGHTER TOTAL WEIGHT IS USED; OR IF A FOUNDATION SOIL WITH A HIGHER DRAINED INTERNAL ANGLE OF FRICTION OR A HIGHER UNDRAINED SHEAR STRENGTH IS ENCOUNTERED, THEN THE STABILITY OF THE WINGWALLS IS SATISFACTORY.

FORESLOPE WALL ANCHOR DOWELS:

AS AN ALTERNATIVE TO RESIN BONDING, THREADED INSERTS OR NONPROTRUDING MECHANICAL CONNECTORS CAST INTO THE CULVERT BY THE MANUFACTURER MAY BE USED PROVIDED THEY CAN RESIST AN ULTIMATE PULL-OUT STRENGTH OF 12 KIPS AND MAINTAIN A MINIMUM COVER OF 3 INCHES AT THE BOTTOM OF THE CULVERT SLAB. MECHANICAL CONNECTORS MUST PROVIDE AN "L-SHAPED" BAR INSIDE THE CULVERT WITH A MINIMUM HORIZONTAL LENGTH OF 12 INCHES. PAYMENT FOR INSERTS OR MECHANICAL CONNECTORS SHALL BE INCLUDED WITH ITEM 611.

TYPICAL ABBREVIATIONS:

- C.J. - CONSTRUCTION JOINT
- CLR. - CLEAR
- DIA. - DIAMETER
- E.F. - EACH FACE
- EQ. - EQUAL
- F.F. - FAR FACE
- INV. - INVERT
- PEJF. - PREFORMED EXPANSION JOINT FILLER
- MIN. - MINIMUM
- N.F. - NEAR FACE
- SPA. - SPACING / SPACE
- T. - TOP
- B. - BOTTOM
- T&B. - TOP AND BOTTOM
- TYP. - TYPICAL

POROUS BACKFILL WITH GEOTEXTILE FABRIC:

POROUS BACKFILL WITH GEOTEXTILE FABRIC 1'-6" THICK SHALL BE PLACED BEHIND THE WINGWALLS ONLY AND SHALL EXTEND TO 12" BELOW THE EMBANKMENT SURFACE. GEOTEXTILE FABRIC SHALL BE PLACED BETWEEN THE POROUS BACKFILL AND REPLACED EXCAVATION ADJACENT TO THE STRUCTURE. IT SHALL TURN UNDER THE BOTTOM OF THE POROUS BACKFILL AND RETURN 6" ABOVE THE TOP ELEVATION OF THE WEEPHOLE. WEEPHOLES SHALL BE PLACED 6" TO 12" ABOVE THE NORMAL WATER ELEVATION OR GROUND LINE AND SHALL HAVE A MAXIMUM SPACING OF 10'-0". A MINIMUM OF ONE WEEPHOLE SHALL BE PROVIDED PER WINGWALL.

ITEM 611 - 6' X 4' CONDUIT, TYPE A, 706.05, AS PER PLAN

ALL REQUIREMENTS OF 706.05 SHALL BE MET. THE 30 DAY WAITING PERIOD PER C&MS 611.12 SHALL BE WAIVED. IN LIEU OF THE BACKFILL REQUIREMENTS OF C&MS 611.06, PROVIDE LOW STRENGTH MORTAR BACKFILL TO THE LIMITS AS DETAILED ON THIS SHEET.

PREFORMED EXPANSION JOINT FILLER:

PREFORMED EXPANSION JOINT FILLER: PREFORMED EXPANSION JOINT FILLER (PEJF) CONFORMING TO CMS 705.03, 1 INCH THICK, SHALL BE PLACED ABOVE THE FOOTING BETWEEN THE SIDES OF THE BOX CULVERT AND THE ENDS OF THE WINGWALLS. PAYMENT FOR MATERIALS AND INSTALLATION SHALL BE INCLUDED WITH ITEM 516 - 1" PREFORMED EXPANSION JOINT FILLER.

SEALING OF FORESLOPE WALL AND WINGWALLS:

ALL EXPOSED FORESLOPE WALL AND WINGWALL CONCRETE SHALL BE SEALED WITH EPOXY-URETHANE SEALER. THE LIMITS SHALL BE AS SHOWN IN THE DIAGRAMS BELOW. PAYMENT FOR THE EPOXY-URETHANE SEALER SHALL BE PER ITEM 512 - SEALING OF CONCRETE SURFACES, (EPOXY-URETHANE).

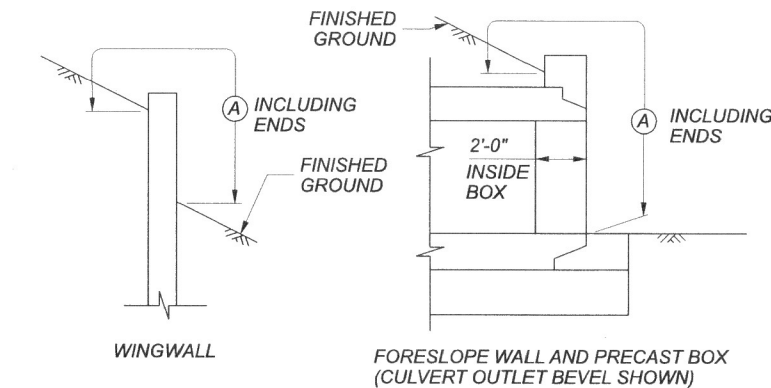

LIMITS OF ITEM 512-SEALING CONCRETE SURFACES WITH (EPOXY-URETHANE)

(A) - SEAL ENTIRE CONCRETE SURFACE AREA

ITEM 503, COFFERDAMS AND EXCAVATION BRACING, AS PER PLAN:

STEEL SHEET PILING SHALL MEET THE DESIGN PARAMETERS LISTED BELOW. ASTM A572, GRADE 50 STEEL SHALL BE USED. THE MINIMUM SECTION MODULUS WILL ALLOW FOR PZ22 OF LARGER SECTION.

DESIGN PARAMETERS				
LOCATION	SECTION MODULUS	RETAINED HEIGHT	EMBEDMENT	SHEETING LENGTH
SEE SHEETS 3 & 4	18 CUBIC IN./FT. (MIN.)	10 FT. (MAX.)	10 FT. (MIN.)	20 FT. (MIN.)

THE CONTRACTOR MAY CONSTRUCT STEEL SHEET PILING EXCAVATION BRACING AS DESCRIBED ABOVE OR PREPARE AN ALTERNATIVE DESIGN TO SUPPORT THE SIDES OF EXCAVATIONS. IF CONSTRUCTING AN ALTERNATIVE DESIGN FOR TEMPORARY SUPPORT OF EXCAVATION, PREPARE AND PROVIDE PLANS IN ACCORDANCE WITH CMS 501.05. THE DEPARTMENT WILL PAY FOR THE TEMPORARY SUPPORT OF EXCAVATION AT THE CONTRACT LUMP SUM PRICE FOR ITEM 503, COFFERDAMS AND EXCAVATION BRACING, AS PER PLAN. NO ADDITIONAL PAYMENT WILL BE MADE FOR PROVIDING AN ALTERNATE DESIGN.

ITEM 613 - LOW STRENGTH MORTAR BACKFILL

TO BE PLACED FROM END TO END OF POROUS BACKFILL.

CALCULATION:
 LEFT SIDE = $[2' + (2' + 4')] / 2 \times 4' \times 73' / 27 = 43.26$ C.Y.
 RIGHT SIDE = $[2' + (2' + 4')] / 2 \times 4' \times 73' / 27 = 43.26$ C.Y.

TOTAL = 86.52 C.Y. (USE 87 C.Y.)
 (01/STR/CV)

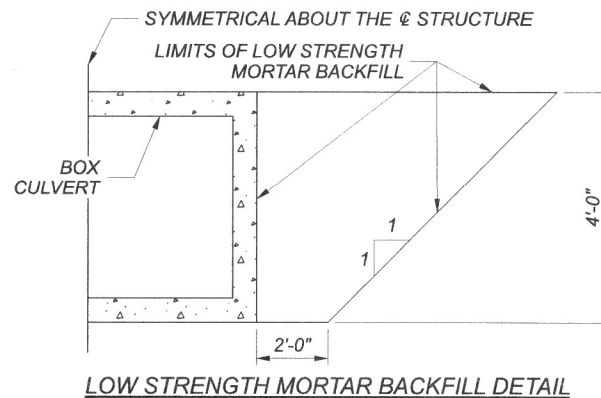

WATERPROOFING:

TYPE 2 WATERPROOFING, PER CMS 512.09 AND 711.25, SHALL EXTEND VERTICALLY DOWN THE ENTIRE SIDES OF THE PRECAST CULVERT SECTIONS FOR ALL PORTIONS OF THE CULVERT WHICH SHALL BE IN CONTACT WITH THE BACKFILL. PAYMENT FOR THE MEMBRANE WATERPROOFING SHALL BE AT THE CONTRACT PRICE BID PER SQUARE YARD FOR ITEM 512 - TYPE 2 WATERPROOFING.

IF PAVEMENT IS NOT PLACED DIRECTLY ON TOP OF THE CULVERT, TYPE 2 WATERPROOFING, PER CMS 512.09 AND 711.25 SHALL BE APPLIED TO THE ENTIRE TOP SURFACE OF THE PRECAST CULVERT SECTIONS AND SHALL EXTEND ONE FOOT VERTICALLY DOWN THE SIDES FOR ALL PORTIONS OF THE CULVERT WHICH SHALL BE IN CONTACT WITH THE BACKFILL. PAYMENT FOR THE MEMBRANE WATERPROOFING SHALL BE AT THE CONTRACT PRICE BID PER SQUARE YARD FOR ITEM 512 - TYPE 2 WATERPROOFING.

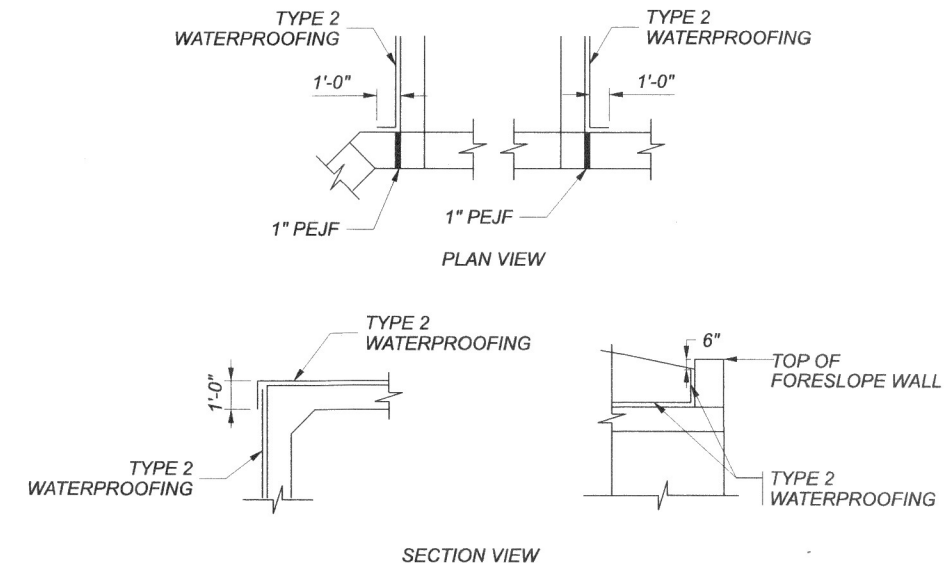

ESTIMATED QUANTITIES				DESIGNED:	LA	CHECKED:	GTB
ITEM	TOTAL	UNIT	DESCRIPTION	DATE:	7/12/2022	DATE:	7/13/2022
202	LUMP		STRUCTURE REMOVED				
503	LUMP		COFFERDAMS AND EXCAVATION BRACING, AS PER PLAN				
503	59	CY	UNCLASSIFIED EXCAVATION				
509	3447	LB	EPOXY COATED REINFORCING STEEL				
511	7	CY	CLASS QC1 CONCRETE, RETAINING/WINGWALL NOT INCLUDING FOOTING				
511	19	CY	CLASS QC1 CONCRETE, FOOTING				
511	1	CY	CLASS QC1 CONCRETE, HEADWALL				
512	36	SY	SEALING OF CONCRETE SURFACES (EPOXY-URETHANE)				
512	169	SY	TYPE 2 WATERPROOFING				
516	27	SF	1" PREFORMED EXPANSION JOINT FILLER				
518	6	CY	POROUS BACKFILL WITH GEOTEXTILE FABRIC				
611	78	FT	6' X 4' CONDUIT, TYPE A, 706.05, AS PER PLAN, DESIGN COVER 4 FT				
613	87	CY	LOW STRENGTH MORTAR BACKFILL				

TOTAL QUANTITIES ARE CARRIED TO THE GENERAL SUMMARY ON SHEET 18.

GENERAL NOTES AND ESTIMATED QUANTITIES
 CULVERT NO. HOL-00039-11.176
 S.R. 39 OVER UNNAMED TRIBUTARY OF PAINT CREEK

CFN 1977350
 DESIGN AGENCY
 BG
 8510 WILCOX PLACE, SUITE C
 DUBLIN, OHIO 43016
 DESIGNER: JEP
 CHECKER: RG
 REVIEWER: GTB
 PROJECT ID: 111666
 SUBSET: 2
 SHEET: 58
 TOTAL: 8
 TOTAL: 93

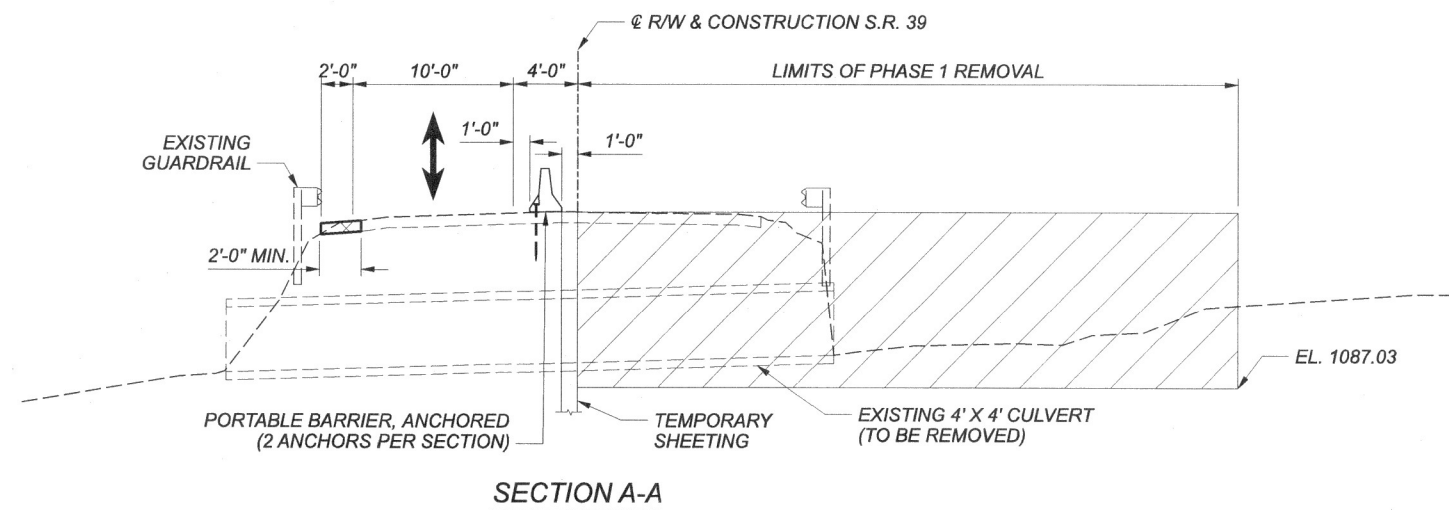
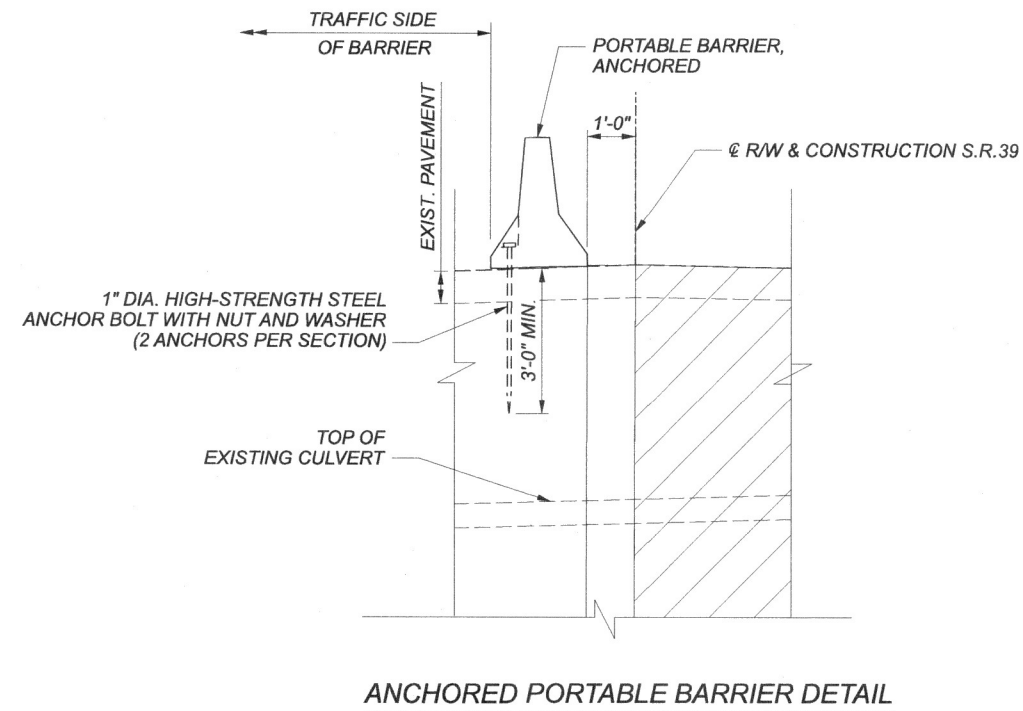
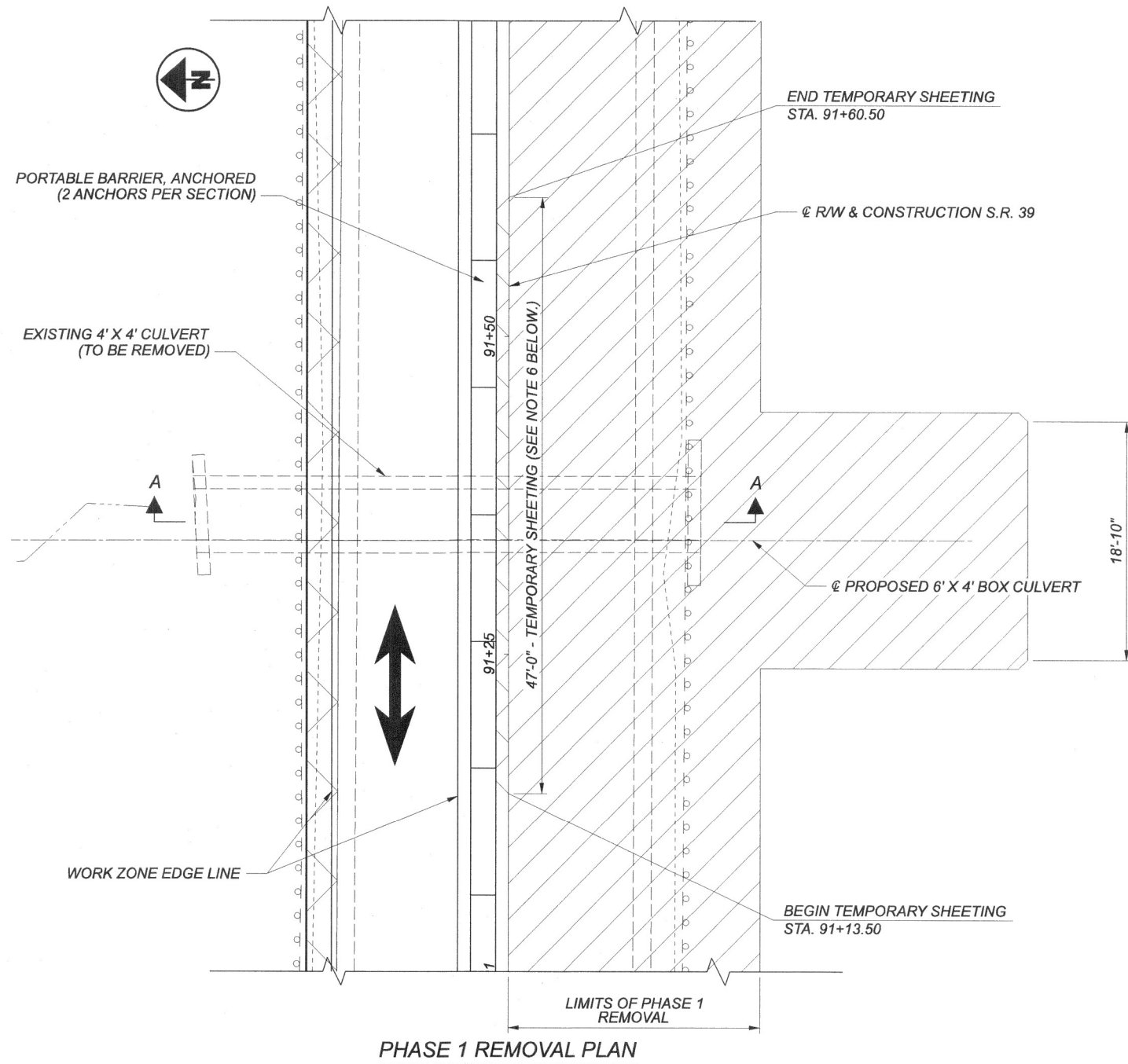

LEGEND:

: PHASE 1 REMOVAL

NOTES:

1. INSTALL TEMPORARY TRAFFIC BARRIER AS SHOWN.
2. SHIFT TRAFFIC TO THE NORTH SIDE OF THE EXISTING STRUCTURE AND MAINTAIN 1-LANE, TWO-WAY TRAFFIC AS SHOWN IN THE MAINTENANCE OF TRAFFIC PLANS.
3. PLACE TEMPORARY SHEETING TO SUPPORT ADJACENT EXISTING ROADWAY EMBANKMENT.
4. REMOVE EXISTING CULVERT TO THE LIMITS SHOWN AND ADDITIONALLY AS REQUIRED PER ITEM 202 TO PROVIDE SUFFICIENT SPACE TO CONSTRUCT THE PROPOSED CULVERT.
5. CONSTRUCT THE SOUTH SIDE OF THE PROPOSED CULVERT TO THE LIMITS SHOWN, IN THE PLANS INCLUDING EXCAVATION BRACING AS NECESSARY.
6. TEMPORARY SHEETING INCLUDED WITH COFFERDAMS AND EXCAVATION BRACING FOR PAYMENT.

PART-WIDTH CONSTRUCTION DETAILS - PHASE 1

CULVERT NO. HOL-00039-11.176

S.R. 39 OVER UNNAMED TRIBUTARY OF PAINT CREEK

CFN	1977350
DESIGN AGENCY	B.G. GROUP www.bggroup.com 5910 WILCOX PLACE, SUITE C DUBLIN, OHIO 43016
DESIGNER	CHECKER
JEP	RG
REVIEWER	
GTB	7-14-22
PROJECT ID	111666
SUBSET	TOTAL
3	8
SHEET	TOTAL
59	93

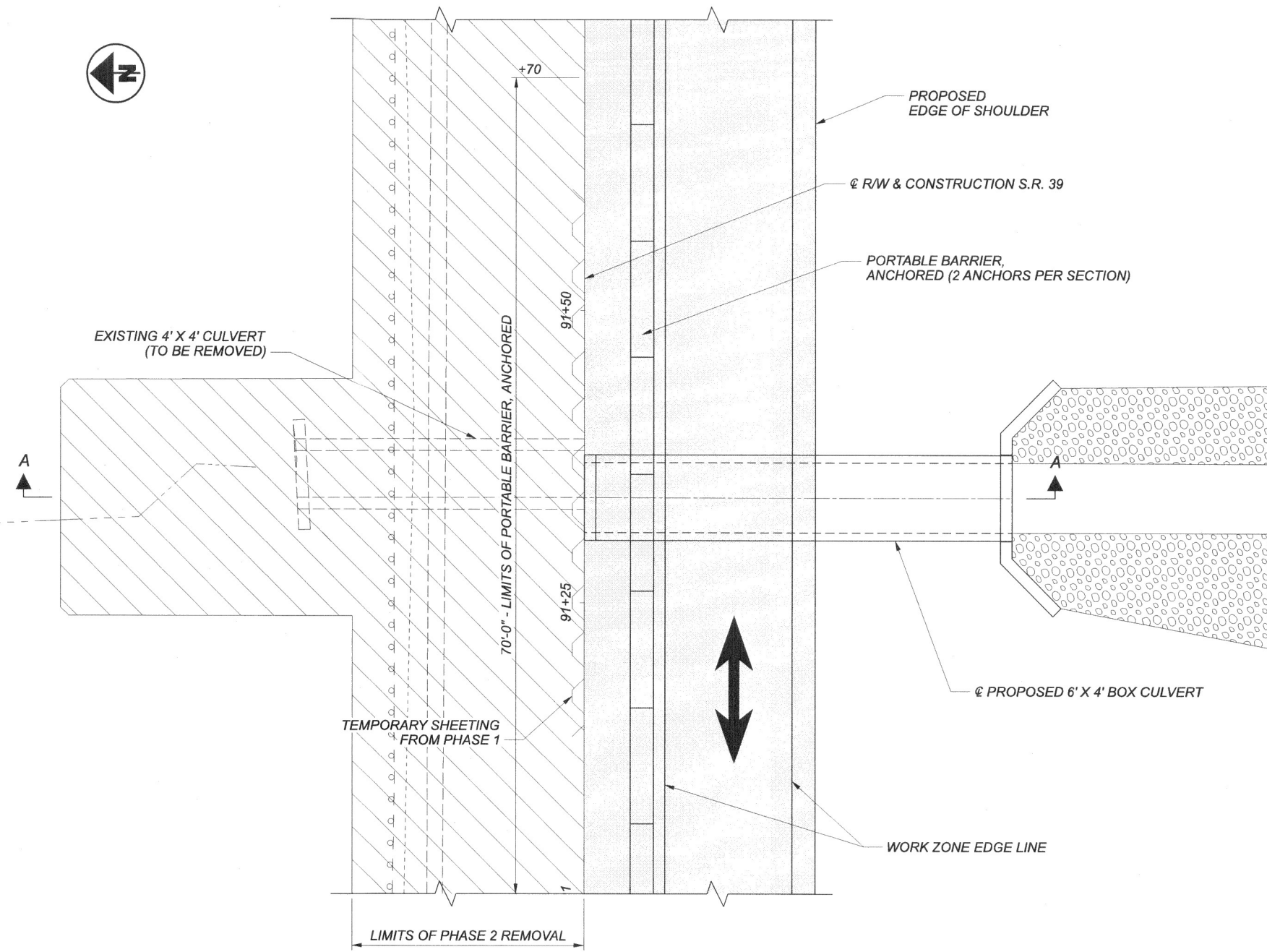

PHASE 1 CONSTRUCTION & PHASE 2 REMOVAL PLAN

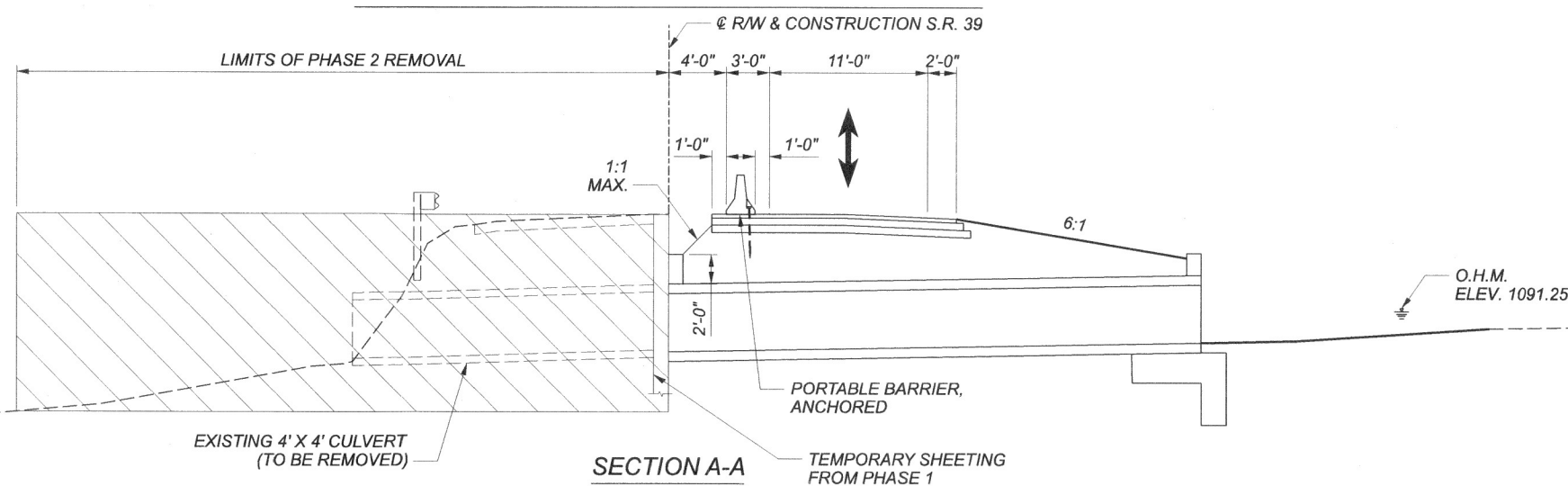

SECTION A-A

LEGEND:

: PHASE 2 REMOVAL

NOTES:

1. INSTALL TEMPORARY TRAFFIC BARRIER AS SHOWN.
2. SHIFT TRAFFIC ONTO THE NEWLY CONSTRUCTED PAVEMENT AND MAINTAIN 1-LANE, TWO-WAY TRAFFIC AS SHOWN IN THE MAINTENANCE OF TRAFFIC PLANS.
3. REMOVE REMAINDER OF EXISTING STRUCTURE AS REQUIRED PER ITEM 202.
4. CONSTRUCT REMAINDER OF THE PROPOSED CULVERT.
5. REMOVE TEMPORARY BARRIERS AND OPEN ROADWAY TO FULL-WIDTH TRAFFIC.

PART-WIDTH CONSTRUCTION DETAILS - PHASE 2

CULVERT NO. HOL-00039-11.176
 S.R. 39 OVER UNNAMED TRIBUTARY OF PAINT CREEK

CFN	1977350
DESIGN AGENCY	BG
DESIGNER	JEP
CHECKER	RG
REVIEWER	GTB
REVIEW DATE	7-14-22
PROJECT ID	111666
SUBSET	TOTAL
4	8
SHEET	TOTAL
60	93

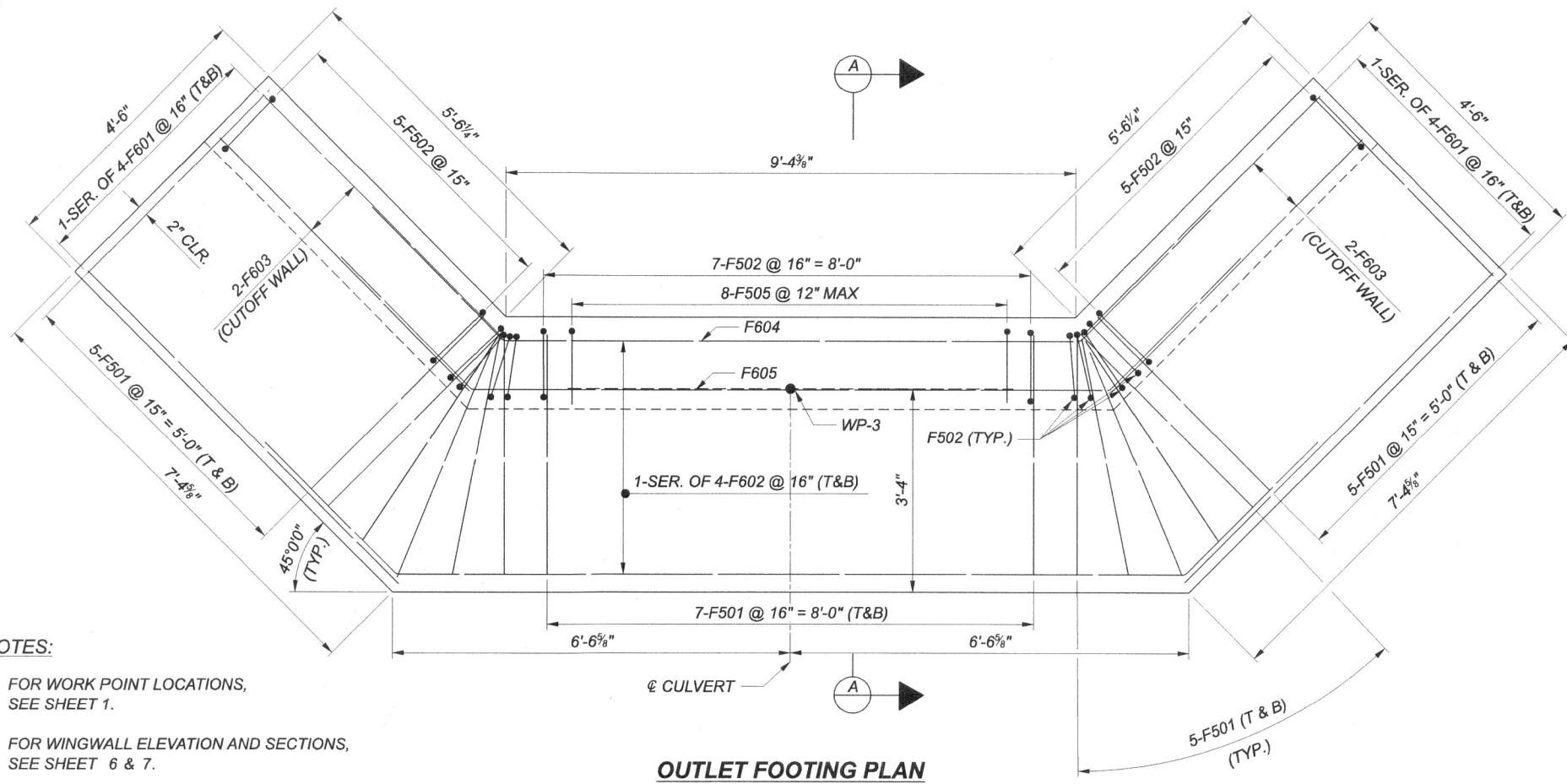

OUTLET FOOTING PLAN

- NOTES:**
1. FOR WORK POINT LOCATIONS, SEE SHEET 1.
 2. FOR WINGWALL ELEVATION AND SECTIONS, SEE SHEET 6 & 7.
 3. CULVERT BOTTOM AND TOP WALL ASSUMED TO BE 7" THICK.

LEGEND:
 A - CLOSURE POUR

MINIMUM LAP LENGTH:
 #5 BAR = 2'-6"
 #6 BAR = 3'-0"

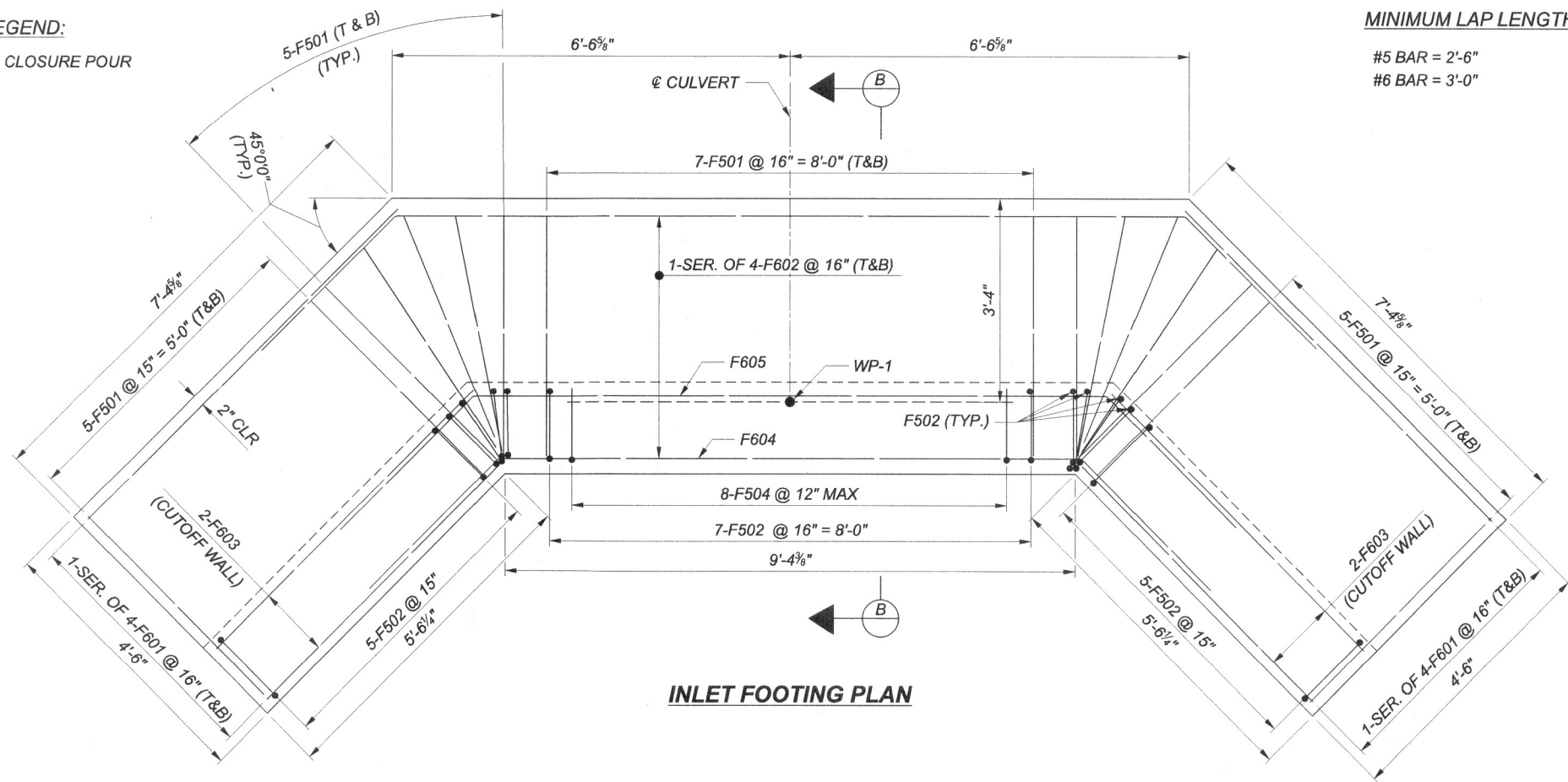

INLET FOOTING PLAN

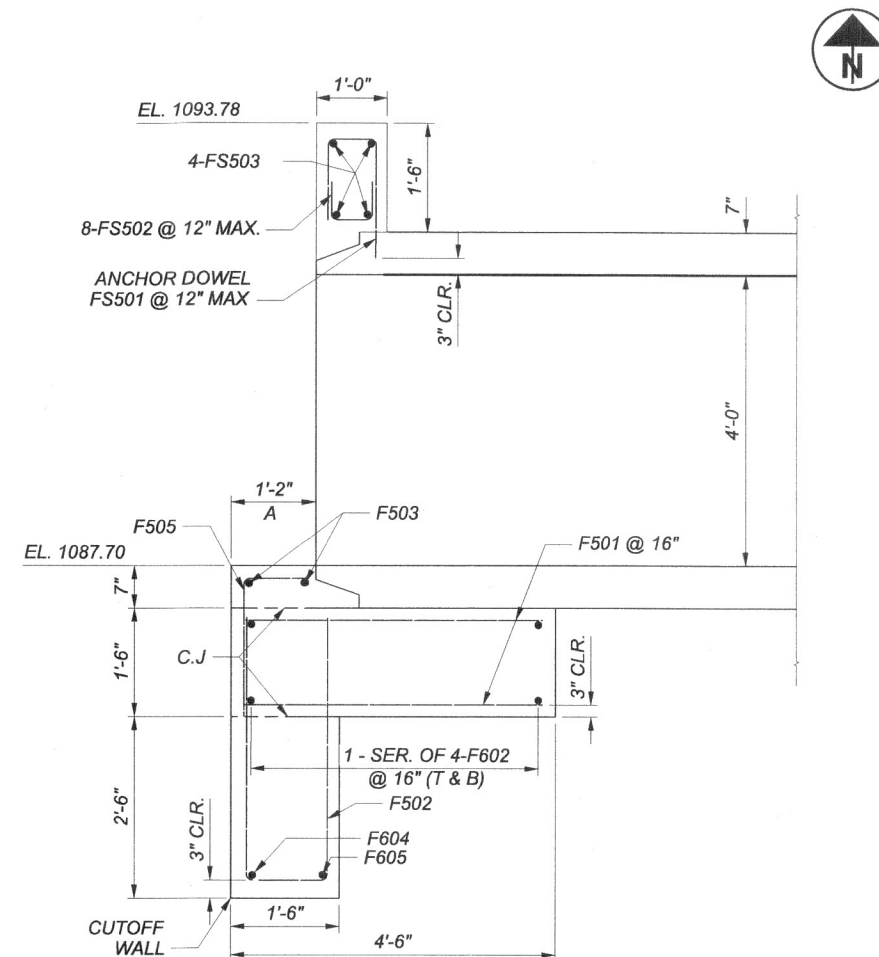

SECTION A-A (OUTLET)

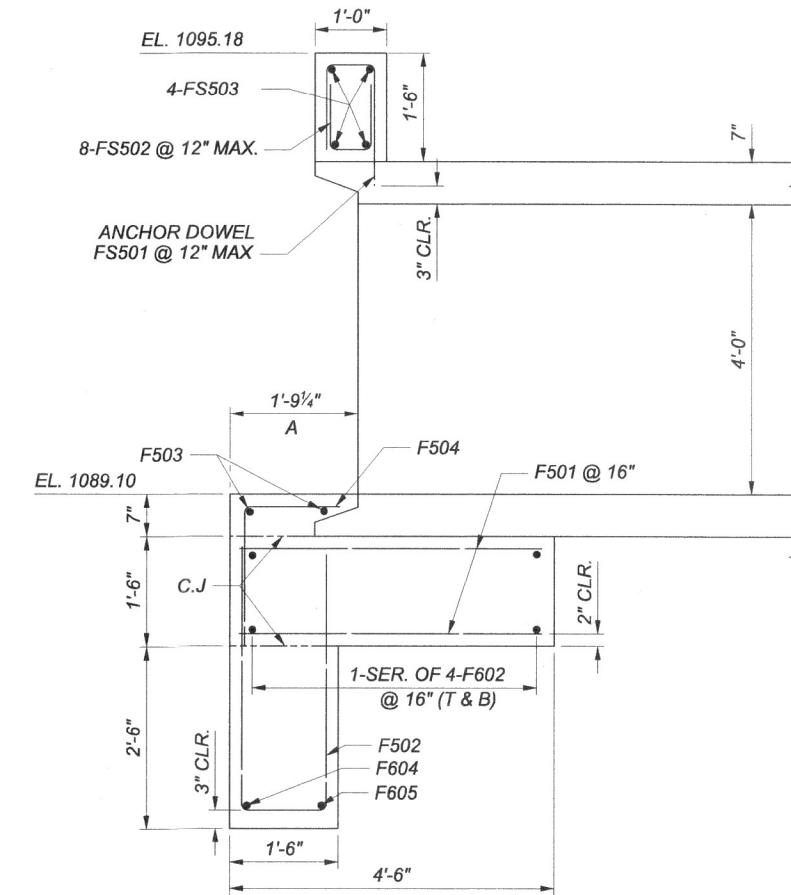

SECTION B-B (INLET)



FOUNDATION PLAN
CULVERT NO. HOL-00039-11.176
S.R. 39 OVER UNNAMED TRIBUTARY OF PAINT CREEK

CFN	1977350
DESIGN AGENCY	www.dbggroup.com
DESIGNER	JEP
CHECKER	RG
REVIEWER	
PROJECT ID	111666
SUBSET	5
TOTAL	8
SHEET	61
TOTAL	93

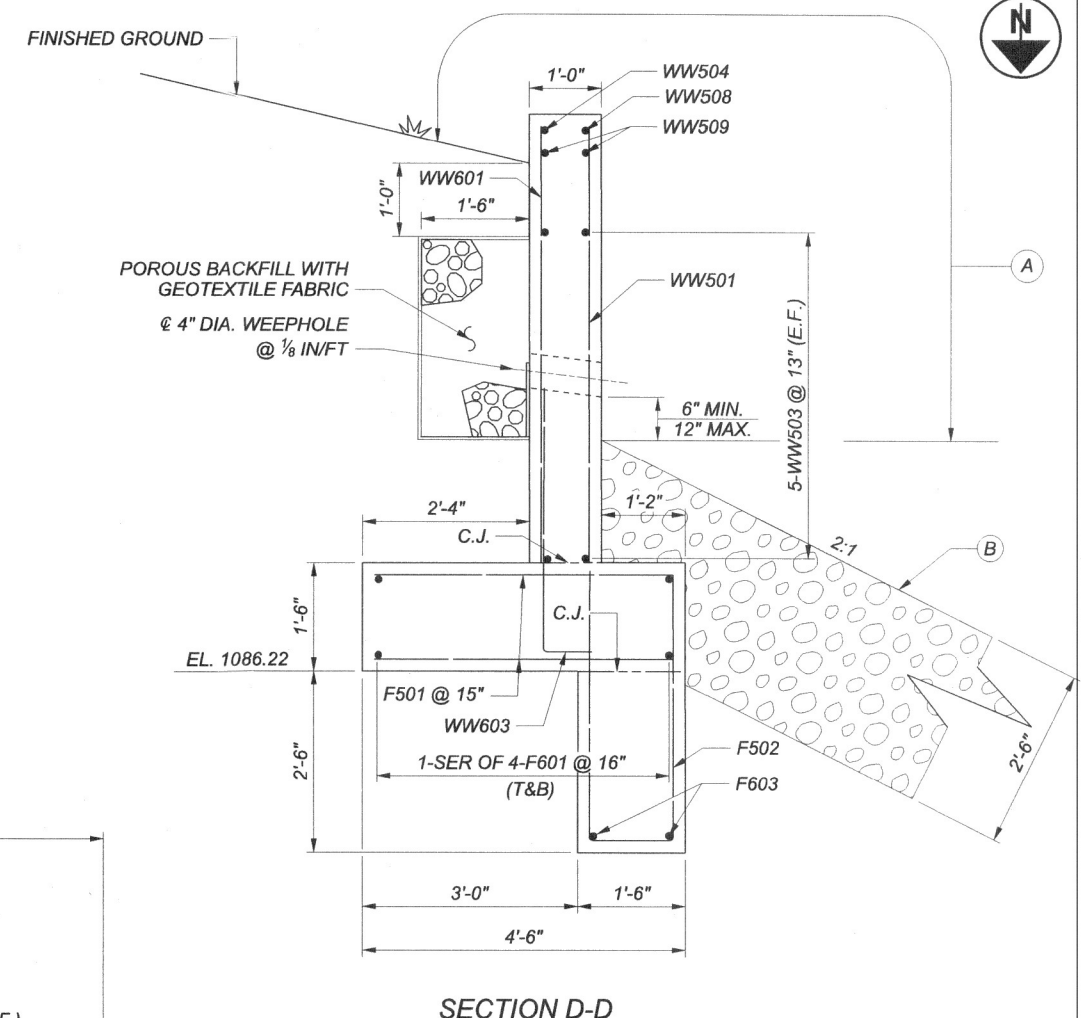
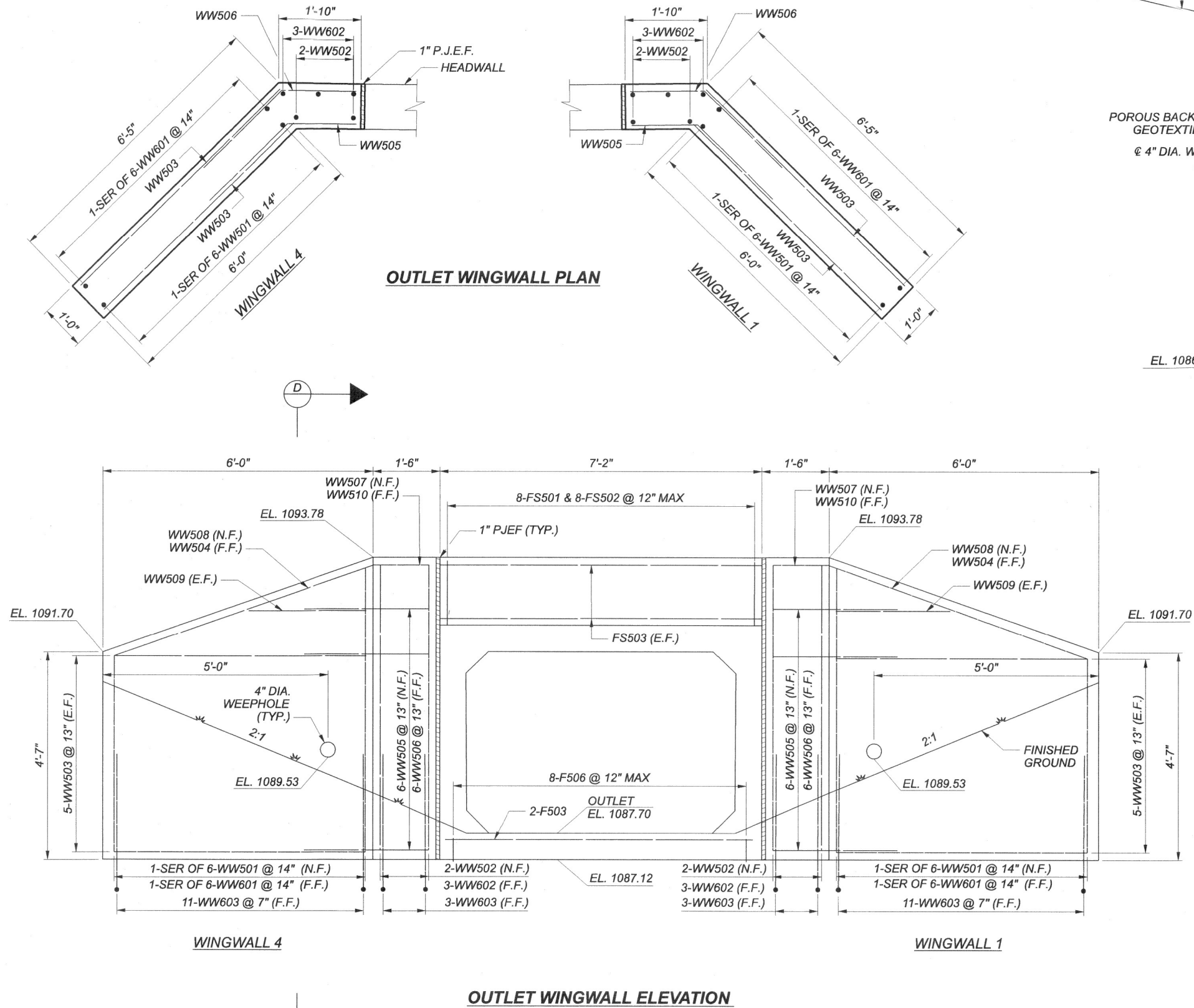

- MINIMUM LAP LENGTH:**
- #5 BAR = 2'-6"
 - #6 BAR = 3'-0"
- NOTES:**
- FOR CULVERT PLAN AND PROFILE, SEE SHEET 1.
 - FOR FOOTING SECTION, SEE SHEET 5.
- LEGEND:**
- (A) = SEALING OF CONCRETE SURFACES (NON-EPOXY)
 - (B) = ROCK CHANNEL PROTECTION TYPE B, WITH GEOTEXTILE FABRIC 2'-6" THICK.

OUTLET WINGWALL DETAIL
 CULVERT NO. HOL-00039-11.176
 S.R. 39 OVER UNNAMED TRIBUTARY OF PAINT CREEK

CFN	1977350
DESIGN AGENCY	B.G.
DESIGNER	JGP
CHECKER	RG
REVIEWER	GTB
PROJECT ID	111666
SUBSET	6
TOTAL	8
SHEET	62
TOTAL	93

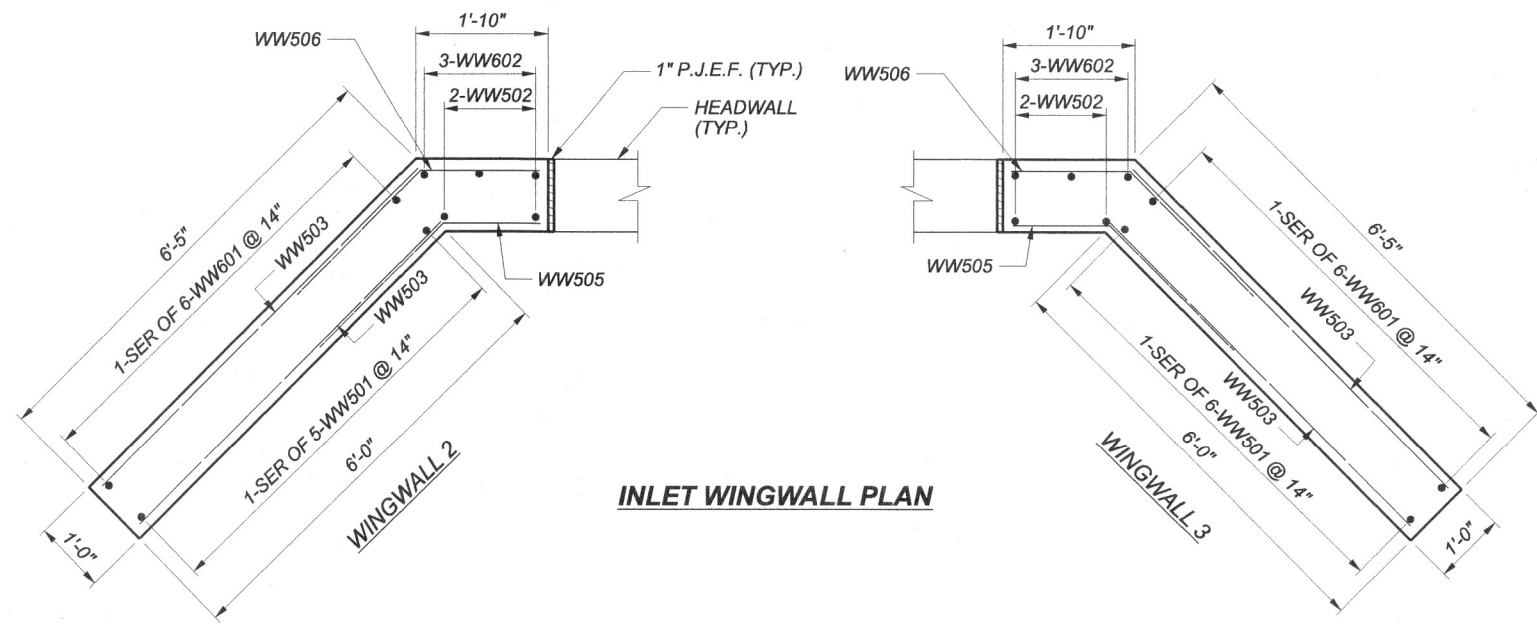

INLET WINGWALL PLAN

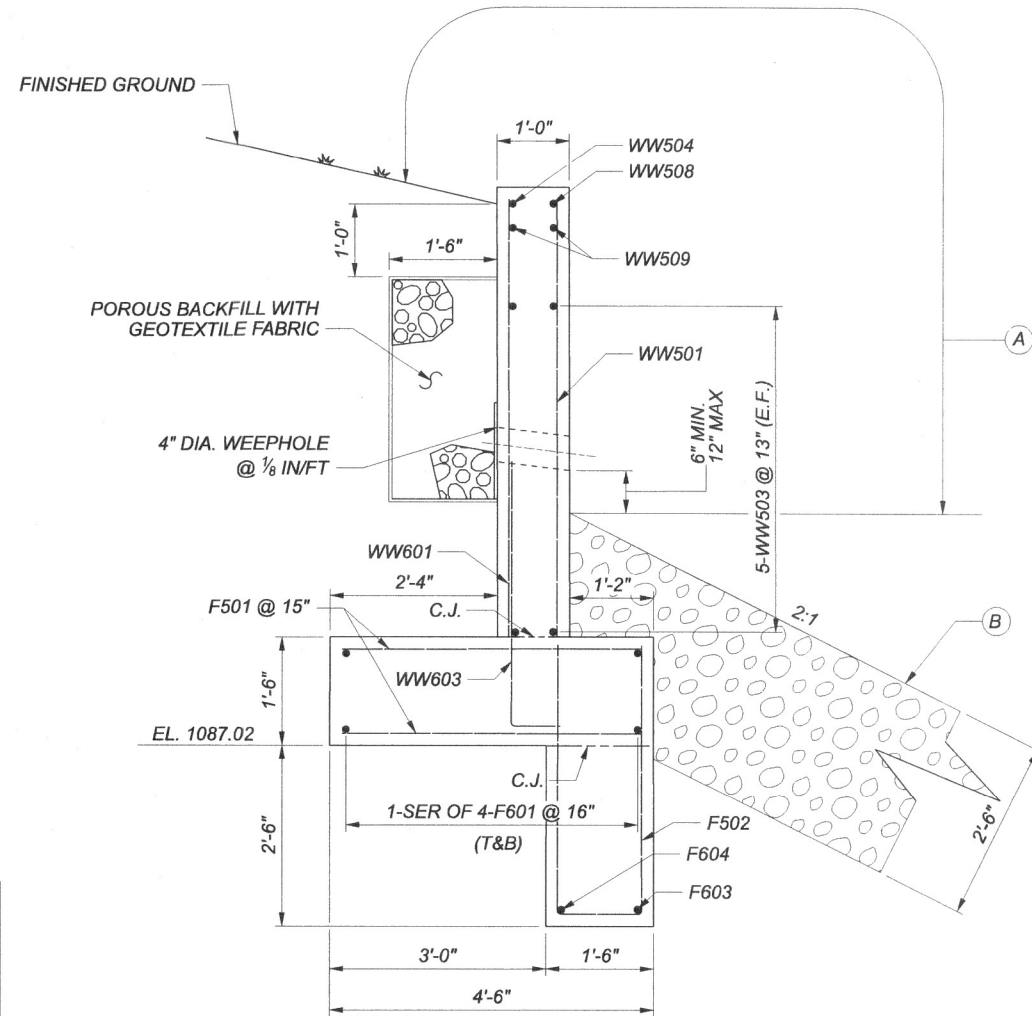

SECTION C-C

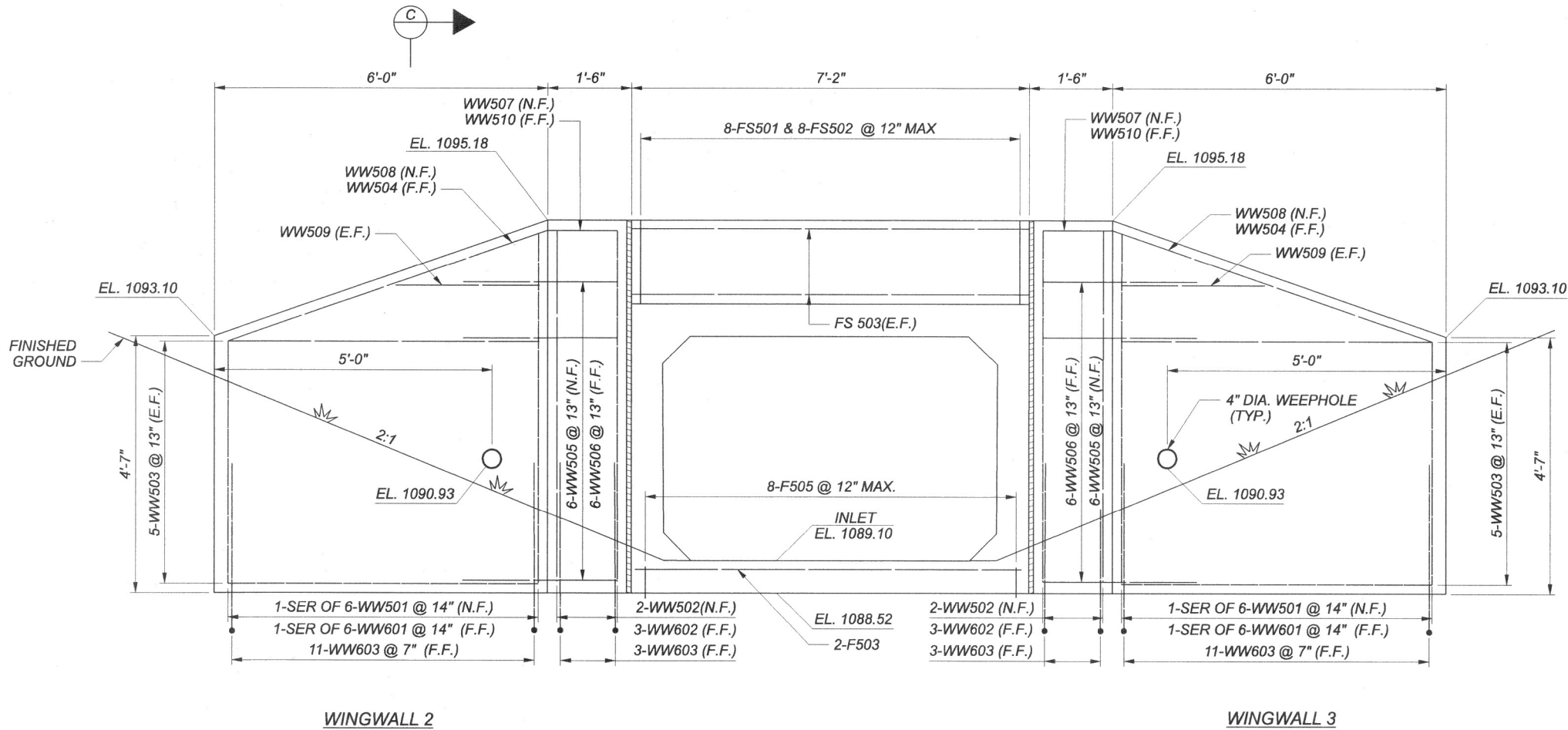

INLET WINGWALL ELEVATION

MINIMUM LAP LENGTH:

- #5 BAR = 2'-6"
- #6 BAR = 3'-0"

NOTES:

1. FOR CULVERT PLAN AND PROFILE, SEE SHEET 1.
2. FOR FOOTING SECTION, SEE SHEET 5.

LEGEND:

- (A) = SEALING OF CONCRETE SURFACES (NON-EPOXY)
- (B) = ROCK CHANNEL PROTECTION TYPE B, WITH GEOTEXTILE FABRIC 2'-6" THICK

INLET WINGWALL DETAIL
CULVERT NO. HOL-00039-11.176
S.R. 39 OVER UNNAMED TRIBUTARY OF PAINT CREEK

CFN	1977350
DESIGN AGENCY	B.G. GROUP, INC. www.bggroup.com 5910 WILCOX PLACE, SUITE C DUBLIN, OHIO 43016
DESIGNER	JEP
CHECKER	RG
REVIEWER	GTB
PROJECT ID	111666
SUBSET	7
TOTAL	8
SHEET	63
TOTAL	93

MARK	NUMBER		LENGTH	WEIGHT	TYPE	DIMENSIONS						
	TOTAL					A	B	C	D	E	R	INC
INLET FOOTING												
F501	54		4'-2"	235	STR							
F502	25		8'-1"	211	2	3'-7"	1'-2"	3'-7"				
F503	2		6'-10"	14	STR							
F504	8		3'-0"	25	1	1'-4"	1'-10"					
F601	4 SER. OF 4		5'-11" TO 7'-1"	156	STR							4 5/8"
F602	2 SER. OF 4		15'-9" TO 19'-3"	210	20	2'-3"	2'-3"	9'-5" TO 12'-11"	2'-3"	2'-3"		1'-2"
F603	4		5'-11"	36	STR							
F604	1		15'-9"	24	20	2'-3"	2'-3"	9'-5"	2'-3"	2'-3"		
F605	1		16'-9"	25	20	2'-3"	2'-3"	10'-5"	2'-3"	2'-3"		
			SUBTOTAL	936								

MARK	NUMBER		LENGTH	WEIGHT	TYPE	DIMENSIONS						
	TOTAL					A	B	C	D	E	R	INC
OUTLET FOOTING												
F501	54		4'-2"	235	STR							
F502	25		8'-1"	211	2	3'-7"	1'-2"	3'-7"				
F503	2		6'-10"	14	STR							
F505	8		2'-6"	21	1	10"	1'-10"					
F601	4 SER. OF 4		5'-6" TO 7'-1"	151	STR							6 3/8"
F602	2 SER. OF 4		15'-9" TO 19'-3"	210	20	2'-3"	2'-3"	9'-5" TO 12'-11"	2'-3"	2'-3"		1'-2"
F603	4		5'-11"	36	STR							
F604	1		15'-9"	24	20	2'-3"	2'-3"	9'-5"	2'-3"	2'-3"		
F605	1		16'-9"	25	20	2'-3"	2'-3"	10'-5"	2'-3"	2'-3"		
			SUBTOTAL	927								

MARK	NUMBER		LENGTH	WEIGHT	TYPE	DIMENSIONS						
	TOTAL					A	B	C	D	E	R	INC
WINGWALLS												
WW501	4 SER. OF 6		4'-5" TO 6'-3"	134	STR							4 3/8"
WW502	8		6'-4"	53	STR							
WW503	40		6'-2"	257	STR							
WW504	4		6'-8"	28	STR							
WW505	24		3'-9"	94	19	1'-4"	1'-9"	1'-9"				
WW506	24		4'-1"	102	19	1'-8"	1'-9"	1'-9"				
WW507	4		1'-3"	5	STR							
WW508	4		6'-4"	26	STR							
WW509	8		2'-7"	22	STR							
WW510	4		1'-6"	6	STR							
WW601	4 SER. OF 6		4'-5" TO 6'-3"	192	STR							4 3/8"
WW602	12		6'-4"	114	STR							
WW603	56		4'-9"	400	1	8"	4'-3"					
			SUBTOTAL	1,433								

MARK	NUMBER		LENGTH	WEIGHT	TYPE	DIMENSIONS						
	TOTAL					A	B	C	D	E	R	INC
HEADWALL (FORESLOPE WALL)												
FS501	16		3'-3"	54	2	1'-2"	8"	1'-8"				
FS502	16		2'-5"	40	2	1'-0"	8"	1'-0"				
FS503	8		6'-10"	57	STR							
			SUBTOTAL	151								

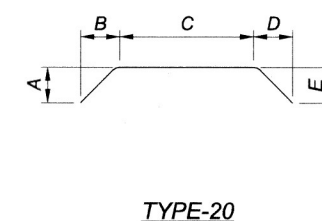
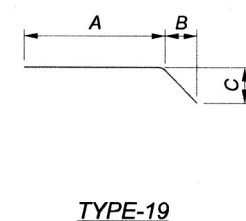
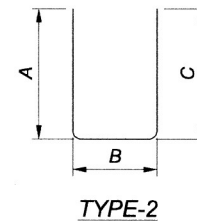
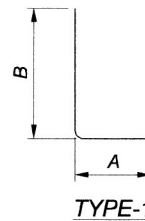

NOTES :

- ALL REINFORCING STEEL SHALL BE EPOXY COATED.
- BAR SIZE: THE BAR SIZE IS INDICATED IN THE BAR MARK. THE MARK BEGINS WITH ONE OR TWO LETTERS THAT IDENTIFY THE BAR LOCATION. THE NEXT ONE OR TWO DIGITS INDICATES THE BAR SIZE, AND THE REMAINING TWO DIGITS ARE THE SEQUENCE NUMBER.
 EXAMPLE: S501
 S = SUPERSTRUCTURE
 5 = # 5 BAR
 01 = BAR SEQUENCE NUMBER 1
- BAR DIMENSIONS SHOWN ARE OUT TO OUT UNLESS NOTED OTHERWISE.
- "STR" IN THE BAR TYPE COLUMN INDICATES A STRAIGHT BAR.
- "INC" INDICATES THE LENGTH INCREMENT FOR SERIES BARS.
- "SER." INDICATES A SERIES OF BARS.

CFN	1977350
DESIGN AGENCY	B.G. GROUP, INC. www.bggroupp.com 5910 WILCOX PLACE, SUITE C DUBLIN, OHIO 43016
DESIGNER	JEP
CHECKER	RG
REVIEWER	GTB
PROJECT ID	7-14-22
	111666
SUBSET	TOTAL
8	8
SHEET	TOTAL
64	93

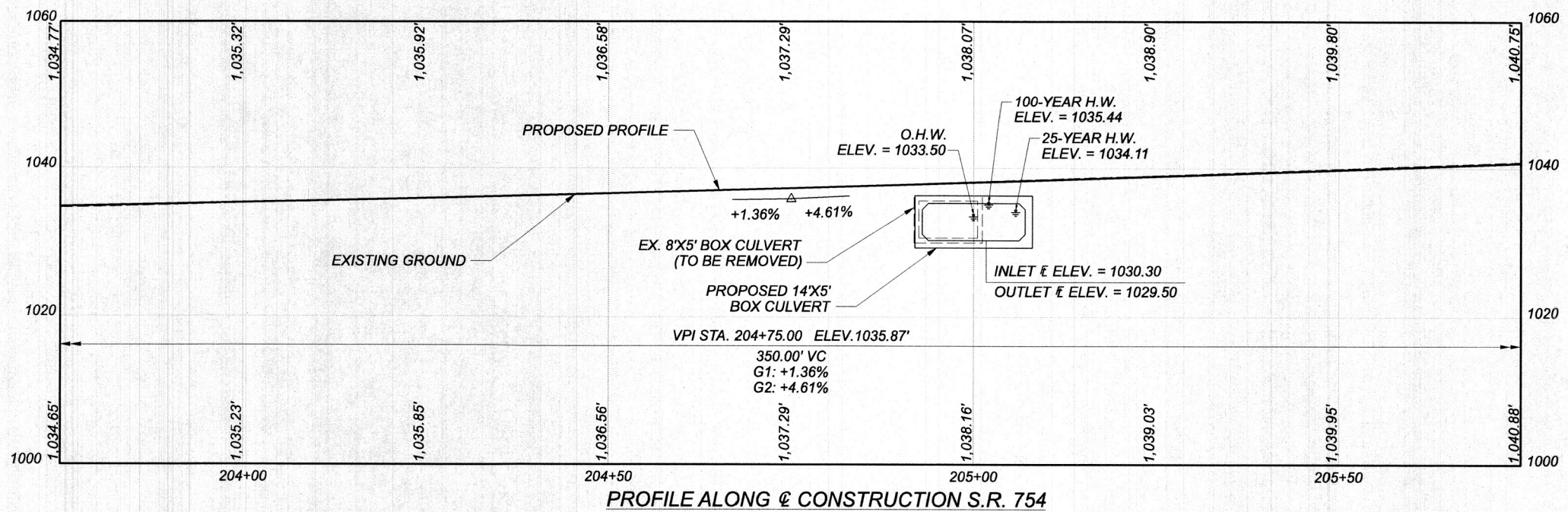
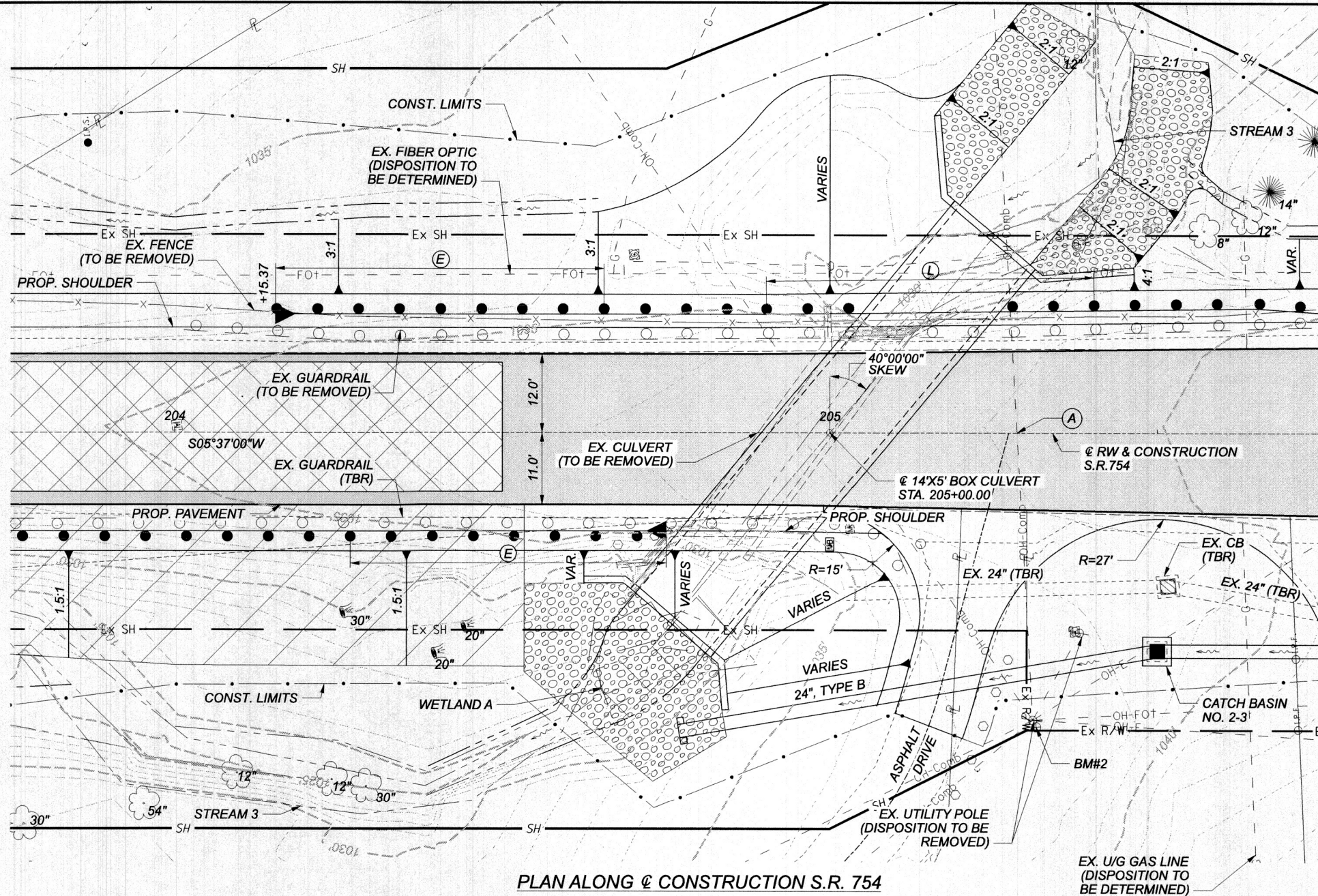

BENCHMARK DATA

BM #1 STA.	204+38.25	ELEV.	1039.53	OFFSET	90.01' LT
BM #2 STA.	205+31.53	ELEV.	1038.37	OFFSET	44.53' RT

FOR ADDITIONAL BENCHMARK INFORMATION, SEE ROADWAY PLAN SHEET 32.

NOTES

EARTHWORK LIMITS SHOWN ARE APPROXIMATE. ACTUAL SLOPES SHALL CONFORM TO PLAN CROSS SECTIONS.

DESIGN TRAFFIC:

2023 ADT =	2700	2023 ADTT =	243
2043 ADT =	3000	2043 ADTT =	270
DIRECTIONAL DISTRIBUTION = 0.60			

LEGEND

- ◆ BORING LOCATION
- ▭ PROPOSED PAVEMENT
- ▨ ROCK CHANNEL PROTECTION, TYPE B WITH GEOTEXTILE FABRIC (2'-6" THICK)
- ▩ RESURFACING
- ▧ PROPOSED DUMP ROCK (SEE TYPICAL SECTIONS FOR DETAILS)
- ▨ WETLAND

- (L) = GUARDRAIL, TYPE MGS, LONG-SPAN = 50.0'
- (A) = ASPHALT DRIVE STA. 205+20.90
- (E) = ANCHOR ASSEMBLY, MGS, TYPE E.

HYDRAULIC DATA

DRAINAGE AREA = 0.53 SQ. MILES	
Q (25) =	310 CFS V (25) = 12.32 FT/S
Q (100) =	476 CFS V (100) = 13.77 FT/S
STRUCTURE CLEARS THE 25 YEAR DESIGN HW BY 1.19 FEET.	

EXISTING STRUCTURE

TYPE: 8'X5' CONCRETE BOX CULVERT
 ROADWAY: 29'-11" F/F GUARDRAIL
 SKEW: 36°00'00"
 ALIGNMENT: TANGENT
 CROWN: 0.016
 CFN: 1810527
 STRUCTURE CONDITION: POOR
 DISPOSITION: TO BE REPLACED

PROPOSED STRUCTURE

TYPE: 14'X5' CONCRETE BOX CULVERT
 76'-0" LONG
 SFN: 3803246
 SPANS: 14' RISE: 5'
 ROADWAY: 33'-0" F/F GUARDRAIL
 LOADING: HL-93 AND 60 PSF FUTURE WEARING SURFACE
 SKEW: 40°00'00"
 WEARING SURFACE: ASPHALT CONCRETE
 APPROACH SLABS: NONE
 ALIGNMENT: TANGENT
 CROWN: 0.016 FT/FT
 COORDINATES: LATITUDE 40°34'43.98"
 LONGITUDE -82°01'15.69"

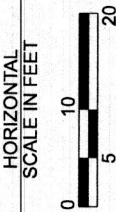

SITE PLAN
BRIDGE NO. HOL-00754-0.169
S.R. 754 OVER UNNAMED TRIBUTARY OF PAINT CREEK

SFN	3803246
DESIGN AGENCY	B.G. GROUP, INC. www.bggroupp.com 5910 WILCOX PLACE, SUITE C DUBLIN, OHIO 43016
DESIGNER	JEP
CHECKER	RG
REVIEWER	GTB
PROJECT ID	111666
SUBSET	TOTAL
1	7
SHEET	TOTAL
65	93

GENERAL NOTES:

DESIGN SPECIFICATION:

THE STRUCTURE CONFORMS TO "LRFD BRIDGE DESIGN SPECIFICATIONS" ADOPTED BY THE AMERICAN ASSOCIATION OF STATE HIGHWAY AND TRANSPORTATION OFFICIALS, 9TH EDITION, 2020 AND THE ODOT BRIDGE DESIGN MANUAL, 2020

DESIGN DATA:

THE FOLLOWING DESIGN DATA IS ASSUMED:

INTERNAL ANGLE OF FRICTION, (ϕ_{bf}) = 30°
 TOTAL UNIT WEIGHT OF BACKFILL SOIL = 120 PCF
 INTERNAL ANGLE OF FRICTION (DRAINED), FOUNDATION SOIL, ϕ_f = 28°
 UNDRAINED SHEAR STRENGTH (COHESIVE), FOUNDATION SOIL, S_{uf} = 1500 PSF
 UNIT WEIGHT OF CONCRETE = 150 PCF
 SLOPE OF BACKFILL = 2:1 (TYPE A & B HEADWALLS)
 HEIGHT OF LIVE LOAD SURCHARGE = 2 FT (TYPE C HEADWALLS)

CONCRETE CLASS QC1 - REQUIRED COMPRESSIVE STRENGTH 4000 PSI (FOOTING, WINGWALL AND FORESLOPE WALL)

REINFORCING STEEL - ASTM A615, A616, OR A617
 GRADE 60 MINIMUM YIELD STRENGTH 60,000 PSI (ALL REINFORCING SHALL BE EPOXY COATED)

BASED ON THE ASSUMED DESIGN DATA, THE WINGWALLS ACHIEVE FACTORED BEARING RESISTANCES THAT ARE GREATER THAN THEIR RESPECTIVE BEARING PRESSURES. IF A BACKFILL MATERIAL WITH A HIGHER INTERNAL ANGLE OF FRICTION OR A LIGHTER TOTAL WEIGHT IS USED; OR IF A FOUNDATION SOIL WITH A HIGHER DRAINED INTERNAL ANGLE OF FRICTION OR A HIGHER UNDRAINED SHEAR STRENGTH IS ENCOUNTERED, THEN THE STABILITY OF THE WINGWALLS IS SATISFACTORY.

FORESLOPE WALL ANCHOR DOWELS:

AS AN ALTERNATIVE TO RESIN BONDING, THREADED INSERTS OR NONPROTRUDING MECHANICAL CONNECTORS CAST INTO THE CULVERT BY THE MANUFACTURER MAY BE USED PROVIDED THEY CAN RESIST AN ULTIMATE PULL-OUT STRENGTH OF 12 KIPS AND MAINTAIN A MINIMUM COVER OF 3 INCHES AT THE BOTTOM OF THE CULVERT SLAB. MECHANICAL CONNECTORS MUST PROVIDE AN "L-SHAPED" BAR INSIDE THE CULVERT WITH A MINIMUM HORIZONTAL LENGTH OF 12 INCHES. PAYMENT FOR INSERTS OR MECHANICAL CONNECTORS SHALL BE INCLUDED WITH ITEM 611.

TYPICAL ABBREVIATIONS:

C.J.	-	CONSTRUCTION JOINT
CLR.	-	CLEAR
DIA.	-	DIAMETER
E.F.	-	EACH FACE
EQ.	-	EQUAL
F.F.	-	FAR FACE
INV.	-	INVERT
PEJF.	-	PREFORMED EXPANSION JOINT FILLER
MIN.	-	MINIMUM
N.F.	-	NEAR FACE
SPA.	-	SPACING / SPACE
T	-	TOP
B	-	BOTTOM
T&B	-	TOP AND BOTTOM
TYP.	-	TYPICAL

ITEM 611 - 14' X 5' CONDUIT, TYPE A, 706.05, AS PER PLAN

ALL REQUIREMENTS OF 706.05 AND SUPPLEMENTAL SPECIFICATION 940 SHALL BE MET. THE 30 DAY WAITING PERIOD PER C&MS 611.12 SHALL BE WAIVED. IN LIEU OF THE BACKFILL REQUIREMENTS OF C&MS 611.06, PROVIDE LOW STRENGTH MORTAR BACKFILL TO THE LIMITS AS DETAILED ON THIS SHEET.

POROUS BACKFILL WITH GEOTEXTILE FABRIC:

POROUS BACKFILL WITH GEOTEXTILE FABRIC 1'-6" THICK SHALL BE PLACED BEHIND THE WINGWALLS ONLY AND SHALL EXTEND TO 12" BELOW THE EMBANKMENT SURFACE. GEOTEXTILE FABRIC SHALL BE PLACED BETWEEN THE POROUS BACKFILL AND REPLACED EXCAVATION ADJACENT TO THE STRUCTURE. IT SHALL TURN UNDER THE BOTTOM OF THE POROUS BACKFILL AND RETURN 6" ABOVE THE TOP ELEVATION OF THE WEEPHOLE. WEEPHOLES SHALL BE PLACED 6" TO 12" ABOVE THE NORMAL WATER ELEVATION OR GROUND LINE AND SHALL HAVE A MAXIMUM SPACING OF 10'-0". A MINIMUM OF ONE WEEPHOLE SHALL BE PROVIDED PER WINGWALL.

PREFORMED EXPANSION JOINT FILLER:

PREFORMED EXPANSION JOINT FILLER: PREFORMED EXPANSION JOINT FILLER (PEJF) CONFORMING TO CMS 705.03, 1 INCH THICK, SHALL BE PLACED ABOVE THE FOOTING BETWEEN THE SIDES OF THE BOX CULVERT AND THE ENDS OF THE WINGWALLS. PAYMENT FOR MATERIALS AND INSTALLATION SHALL BE INCLUDED WITH ITEM 516 - 1" PREFORMED EXPANSION JOINT FILLER.

SEALING OF FORESLOPE WALL AND WINGWALLS:

ALL EXPOSED FORESLOPE WALL AND WINGWALL CONCRETE SHALL BE SEALED WITH EPOXY-URETHANE SEALER. THE LIMITS SHALL BE AS SHOWN IN THE DIAGRAMS BELOW. PAYMENT FOR THE EPOXY-URETHANE SEALER SHALL BE PER ITEM 512 - SEALING OF CONCRETE SURFACES, (EPOXY-URETHANE).

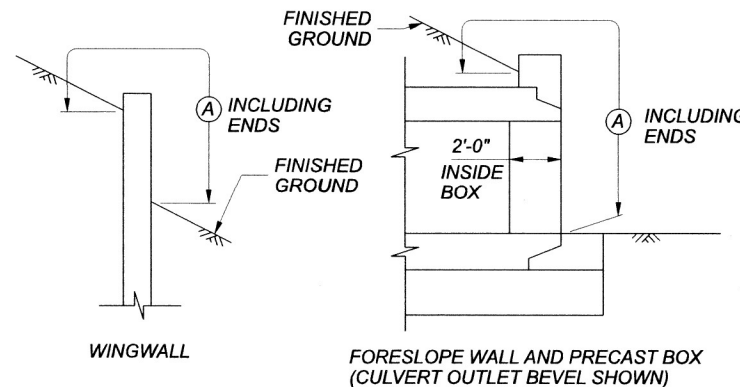

LIMITS OF ITEM 512-SEALING CONCRETE SURFACES WITH (EPOXY-URETHANE)

(A) - SEAL ENTIRE CONCRETE SURFACE AREA

ITEM 613 - LOW STRENGTH MORTAR BACKFILL

TO BE PLACED FROM END TO END OF POROUS BACKFILL.

CALCULATION:
 LEFT SIDE = $[2' + (2' + 5')] / 2 \times 5' \times 72' / 27 = 60.00$ C.Y.
 RIGHT SIDE = $[2' + (2' + 5')] / 2 \times 5' \times 72' / 27 = 60.00$ C.Y.

TOTAL = 120.00 C.Y. (USE 120 C.Y.)
 (01/STR/CV)

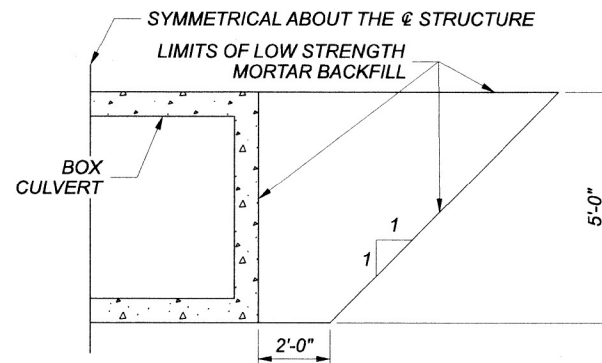

LOW STRENGTH MORTAR BACKFILL DETAIL

WATERPROOFING:

TYPE 2 WATERPROOFING, PER CMS 512.09 AND 711.25, SHALL EXTEND VERTICALLY DOWN THE ENTIRE SIDES OF THE PRECAST CULVERT SECTIONS FOR ALL PORTIONS OF THE CULVERT WHICH SHALL BE IN CONTACT WITH THE BACKFILL. PAYMENT FOR THE MEMBRANE WATERPROOFING SHALL BE AT THE CONTRACT PRICE BID PER SQUARE YARD FOR ITEM 512 - TYPE 2 WATERPROOFING.

IF PAVEMENT IS NOT PLACED DIRECTLY ON TOP OF THE CULVERT, TYPE 2 WATERPROOFING, PER CMS 512.09 AND 711.25 SHALL BE APPLIED TO THE ENTIRE TOP SURFACE OF THE PRECAST CULVERT SECTIONS AND SHALL EXTEND ONE FOOT VERTICALLY DOWN THE SIDES FOR ALL PORTIONS OF THE CULVERT WHICH SHALL BE IN CONTACT WITH THE BACKFILL. PAYMENT FOR THE MEMBRANE WATERPROOFING SHALL BE AT THE CONTRACT PRICE BID PER SQUARE YARD FOR ITEM 512 - TYPE 2 WATERPROOFING.

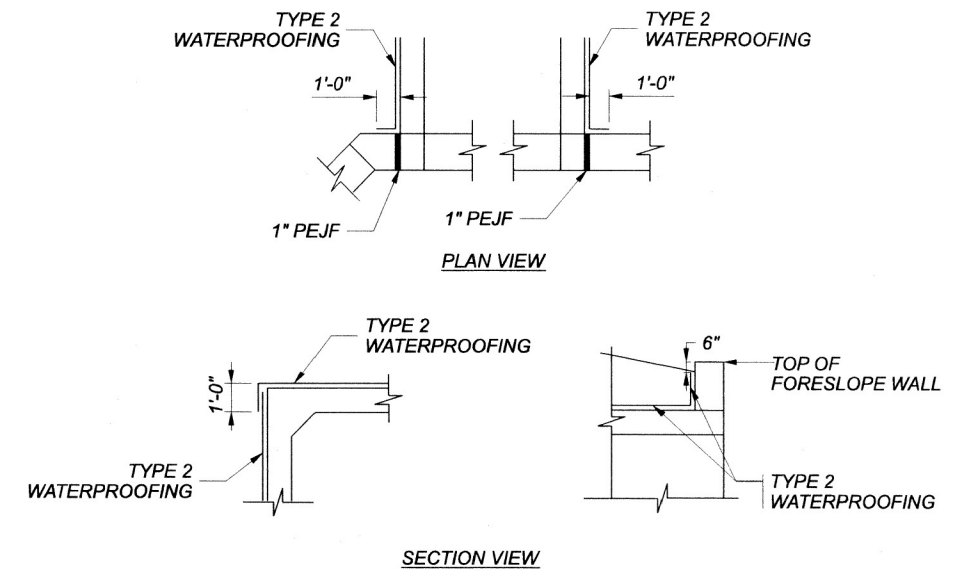

ESTIMATED QUANTITIES				DESIGNED:	LA	CHECKED:	CCJ
ITEM	TOTAL	UNIT	DESCRIPTION	DATE:	7/12/2022	DATE:	7/13/2022
202	LUMP		STRUCTURE REMOVED				
503	LUMP		COFFERDAMS AND EXCAVATION BRACING				
503	98	CY	UNCLASSIFIED EXCAVATION				
509	6381	LB	EPOXY COATED REINFORCING STEEL				
511	13	CY	CLASS QC1 CONCRETE, RETAINING/WINGWALL NOT INCLUDING FOOTING				
511	42	CY	CLASS QC1 CONCRETE, FOOTING				
511	2	CY	CLASS QC1 CONCRETE, HEADWALL				
512	65	SY	SEALING OF CONCRETE SURFACES (EPOXY-URETHANE)				
512	274	SY	TYPE 2 WATERPROOFING				
516	35	SF	1" PREFORMED EXPANSION JOINT FILLER				
518	10	CY	POROUS BACKFILL WITH GEOTEXTILE FABRIC				
611	77	FT	14' X 5' CONDUIT, TYPE A, 706.05, AS PER PLAN, DESIGN COVER 2 FT				
613	120	CY	LOW STRENGTH MORTAR BACKFILL				

TOTAL QUANTITIES ARE CARRIED TO THE GENERAL SUMMARY ON SHEET 18.

GENERAL NOTES AND ESTIMATED QUANTITIES
 BRIDGE NO. HOL-00754-0.169
 S.R. 754 OVER UNNAMED TRIBUTARY OF PAINT CREEK

SFN	3803246
DESIGN AGENCY	B.G. GROUP
DESIGNER	JEP
CHECKER	RG
REVIEWER	GTB
PROJECT ID	111666
SUBSET	2
TOTAL	7
SHEET	66
TOTAL	93

HOL-39754-11.170-16, TUS-93-10-80

MODEL: Sheet PAPER SIZE: 17x11 (in.) DATE: 7/14/2022 TIME: 1:13:09 PM USER: jperchinski
 P:\Transportation\Works\111666_HOL_39-111\B400-Engineering\Structures\111666_HOL_754-0018_SFN_3803246_SIN001.dgn

HOL-39754-11.170.16, TUS-93-10.80

MODEL: Sheet PAPER SIZE: 17x11 (in.) DATE: 7/14/2022 TIME: 1:13:43 PM USER: JPerchinske
 P:\transportation\workspaces\111666_HOL_39754-11.170.16\Engineering\Structures\SFN_3803246\Structures\SFN_3803246.dgn

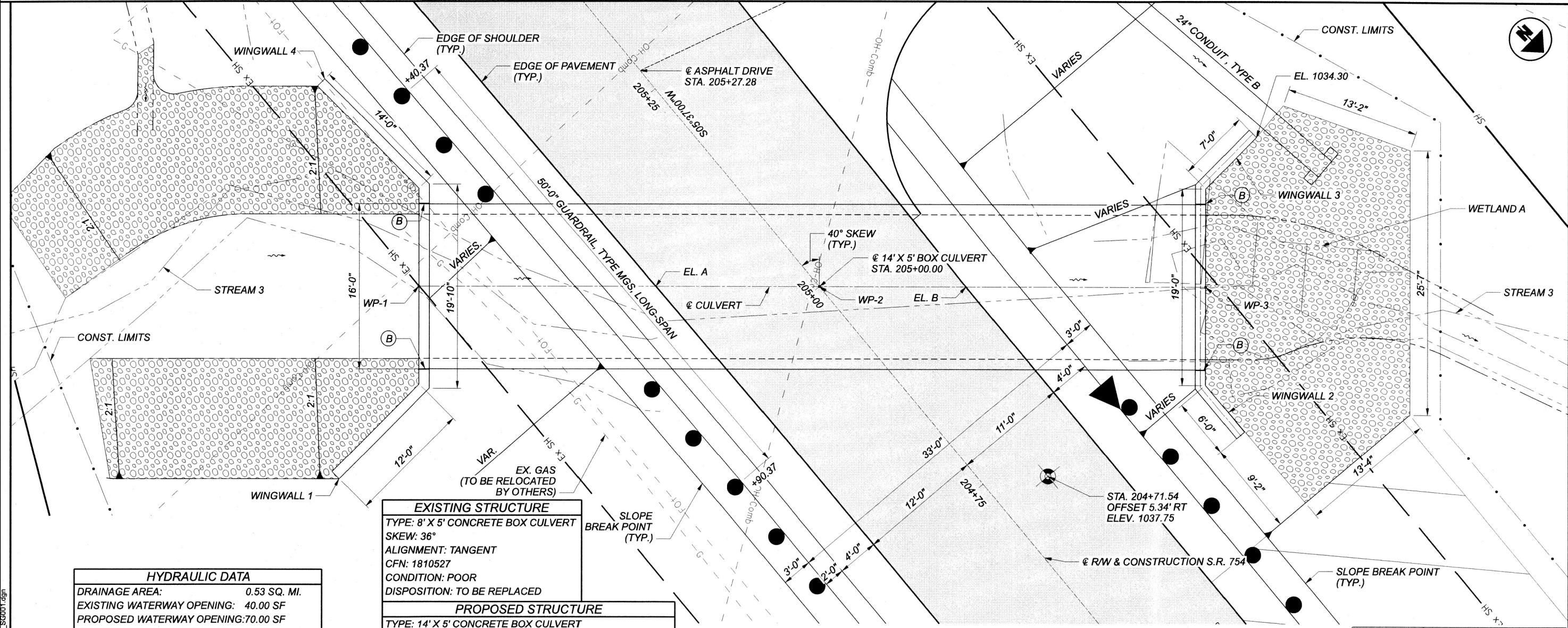

EXISTING STRUCTURE	
TYPE: 8' X 5' CONCRETE BOX CULVERT	
SKEW: 36°	
ALIGNMENT: TANGENT	
CFN: 1810527	
CONDITION: POOR	
DISPOSITION: TO BE REPLACED	
PROPOSED STRUCTURE	
TYPE: 14' X 5' CONCRETE BOX CULVERT	
SKEW: 40°	
ALIGNMENT: TANGENT	
ROADWAY WIDTH: 31'-0" F/F GUARDRAIL	
CROWN: 1.60%	
LOADING: HL-93 AND 60 PSF FUTURE WEARING SURFACE	
DESIGN SERVICE LIFE: 75 YEAR	
SFN: 3803246	

HYDRAULIC DATA	
DRAINAGE AREA: 0.53 SQ. MI.	
EXISTING WATERWAY OPENING: 40.00 SF	
PROPOSED WATERWAY OPENING: 70.00 SF	
ORDINARY HIGH WATER MARK: 1033.50	
DESIGN SERVICE LIFE: 75 YEARS	
Ph: 6.7	
ABRASION LEVEL: NON-ABRASIVE SITE	
Q ₂₅ = 310 CFS	Q ₁₀₀ = 476 CFS
V ₂₅ = 12.32 FPS	V ₁₀₀ = 13.77 FPS
H ₂₅ = 1034.11	H ₁₀₀ = 1035.44

WORK POINT	STA.	OFFSET
WP-1	205+25.19	30.02 LT'
WP-2	205+00.00	0.0
WP-3	204+75.69	28.97 RT'

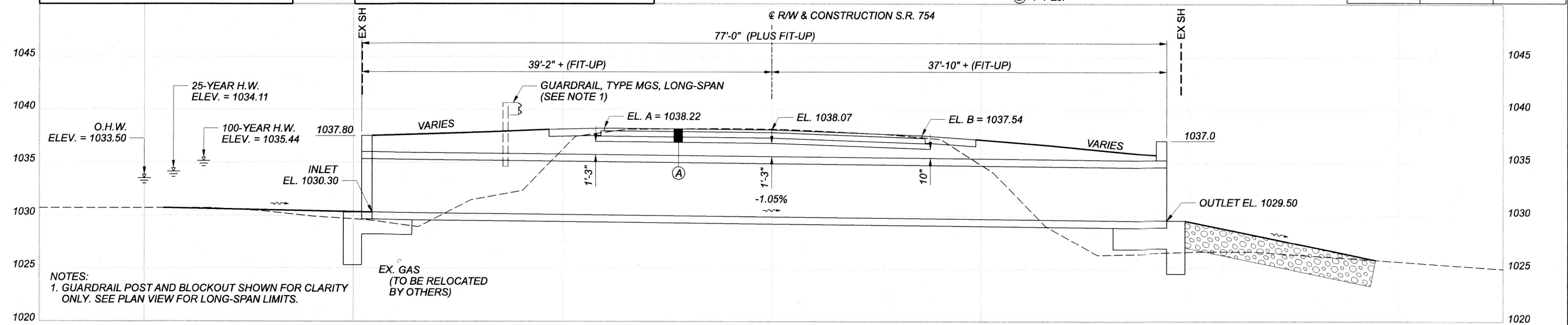

PROFILE ALONG @ CULVERT

CULVERT PLAN AND PROFILE
 BRIDGE NO. HOL-00754-0.169
 S.R. 754 OVER UNNAMED TRIBUTARY OF PAINT CREEK

SFN	3803246
DESIGN AGENCY	BG
DESIGNER	JEP
CHECKER	RG
REVIEWER	GTB
PROJECT ID	111666
SUBSET	3
TOTAL	7
SHEET	67
TOTAL	93

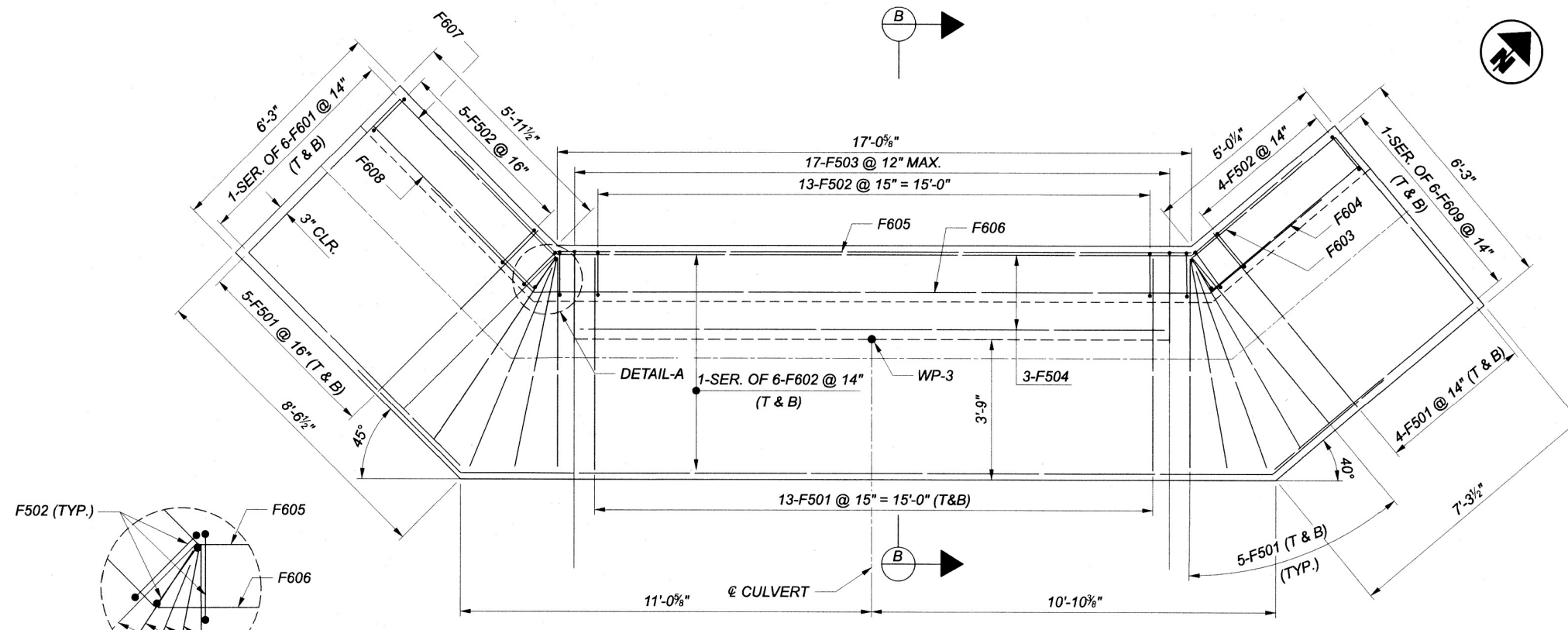

OUTLET FOOTING PLAN

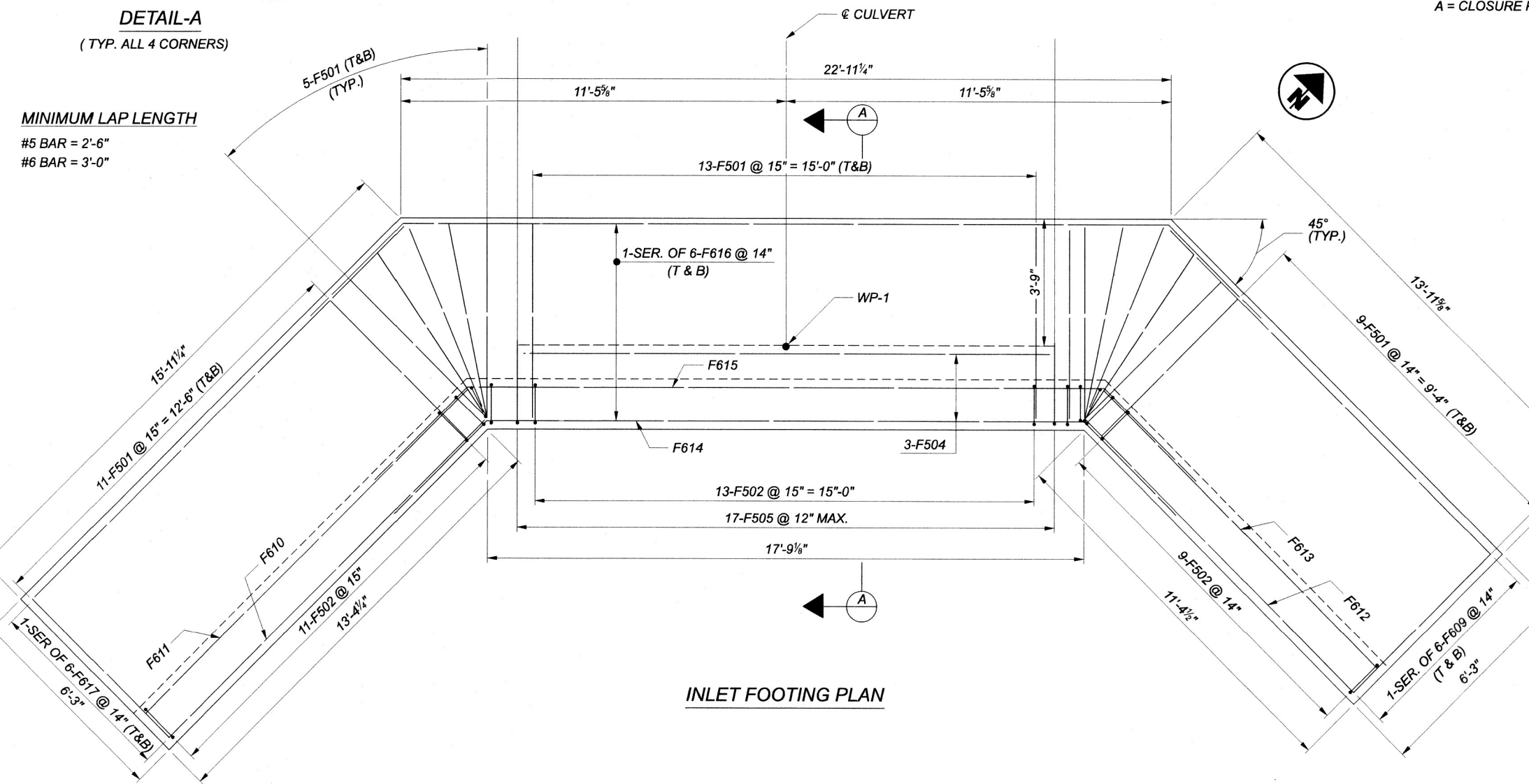

INLET FOOTING PLAN

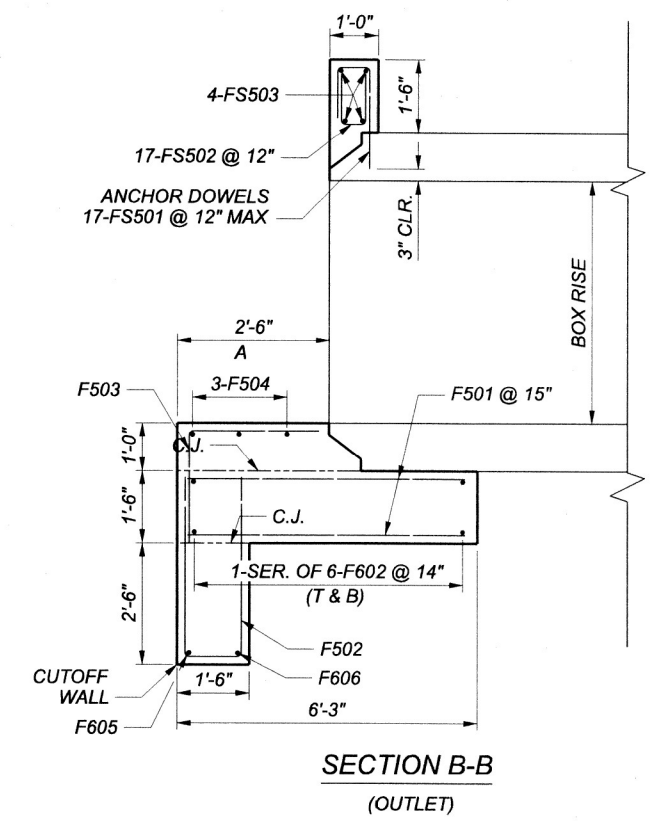

**SECTION B-B
(OUTLET)**

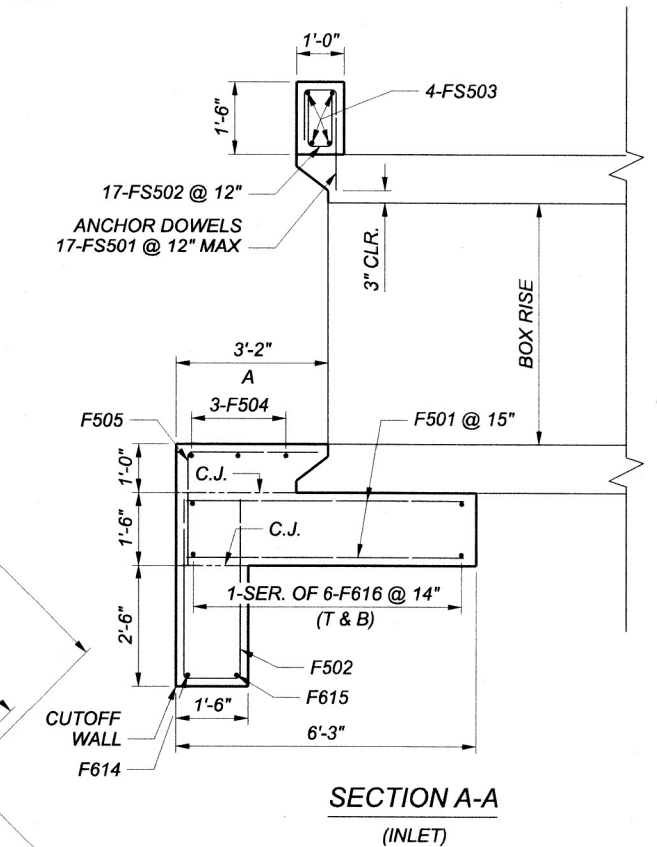

**SECTION A-A
(INLET)**

LEGEND:
 A = CLOSURE POUR

- NOTES:**
1. CULVERT TOP AND BOTTOM WALLS ASSUMED TO BE 12" THICK
 2. FOR WORK POINT LOCATIONS, SEE SHEET 3.
 3. FOR WINGWALL ELEVATION AND SECTIONS, SEE SHEET, 5 & 6.

SFN	3803246
DESIGN AGENCY	B.G. GROUP, INC.
DESIGNER	JEP
CHECKER	RG
REVIEWER	GTB
PROJECT ID	111666
SUBSET	4
TOTAL	7
SHEET	68
TOTAL	93

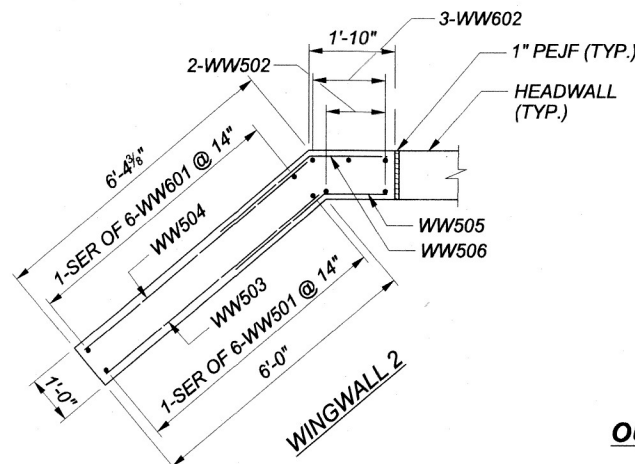

OUTLET WINGWALL PLAN

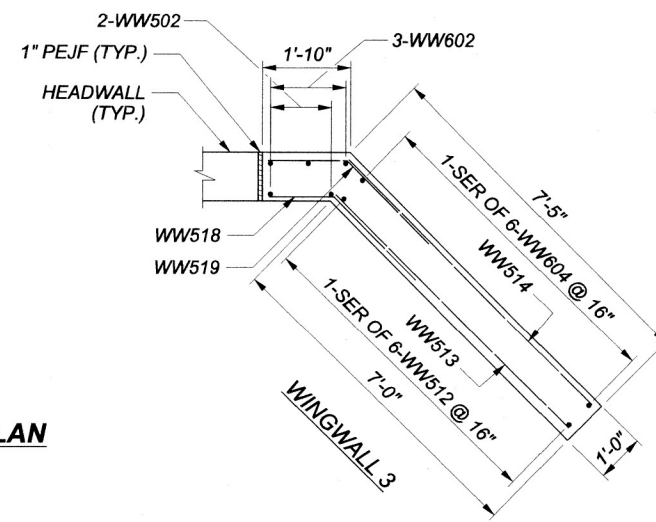

MINIMUM LAP LENGTH

#5 BAR = 2'-6"
 #6 BAR = 3'-0"

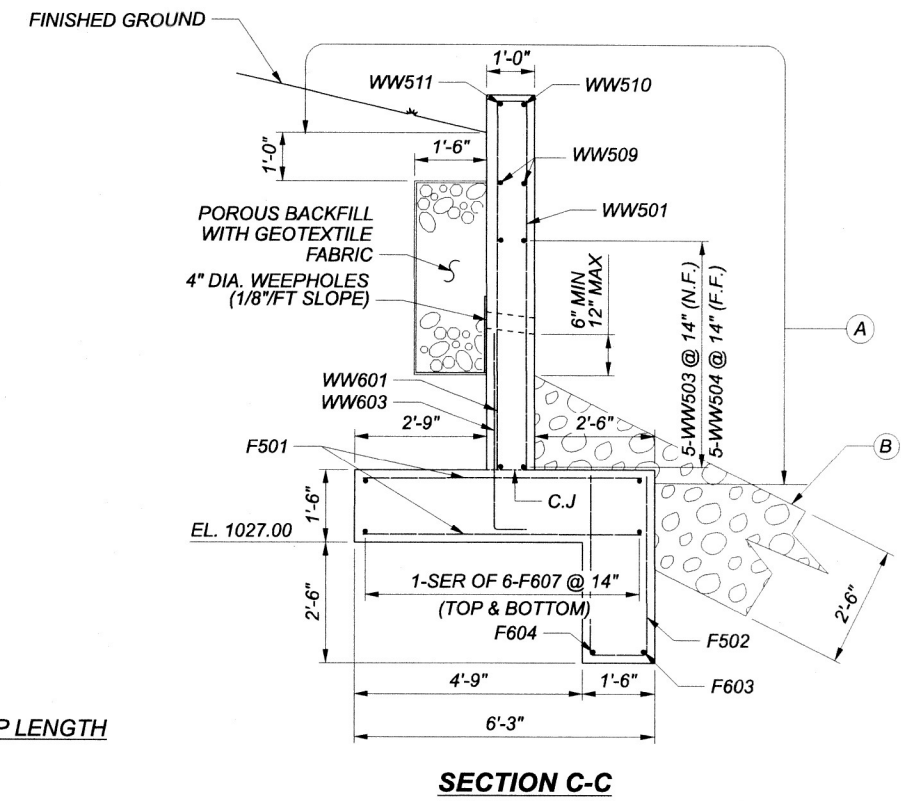

SECTION C-C

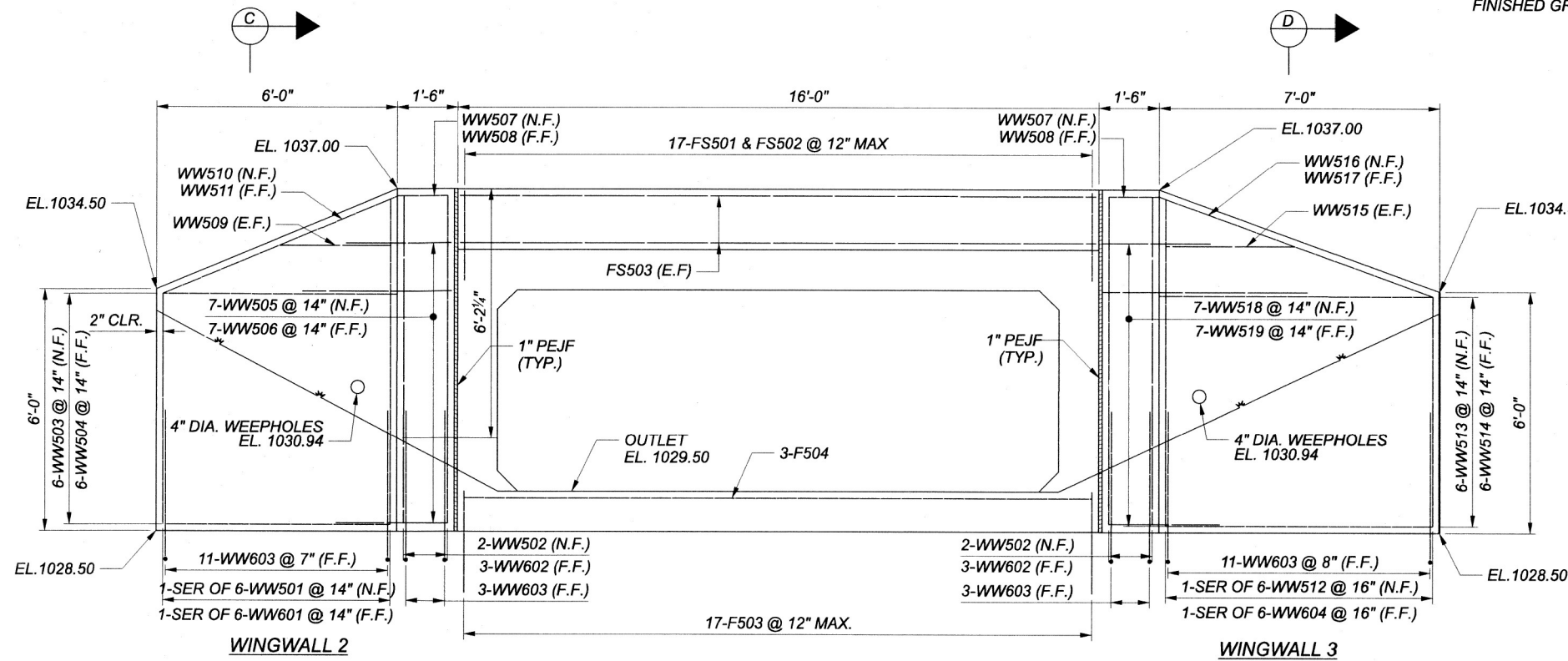

OUTLET WINGWALL ELEVATION

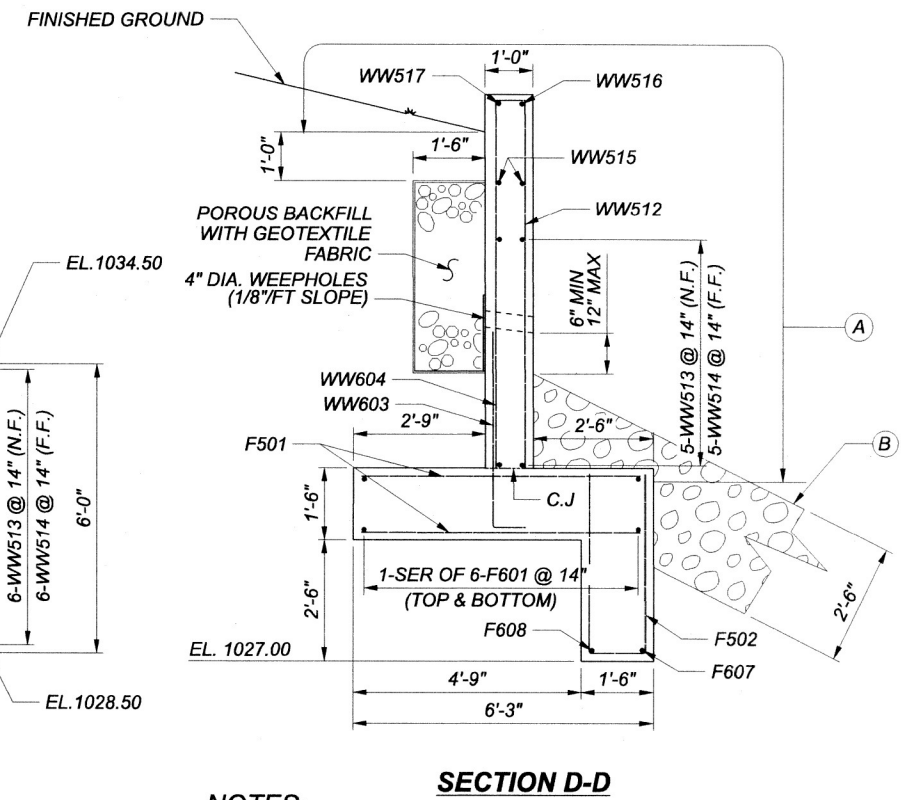

SECTION D-D

- NOTES:**
- FOR CULVERT PLAN AND PROFILE, SEE SHEET 3.
 - FOR FOOTING SECTION, SEE SHEET 4.

- LEGEND:**
- (A) = SEALING OF CONCRETE SURFACES (NON-EPOXY)
 - (B) = ROCK CHANNEL PROTECTION TYPE B, WITH GEOTEXTILE FABRIC 2'-6" THICK.

SFN	3803246
DESIGN AGENCY	B.G. GROUP, INC.
DESIGNER	JEP
CHECKER	RG
REVIEWER	
GTB	7-14-22
PROJECT ID	111666
SUBSET	5
TOTAL	7
SHEET	69
TOTAL	93

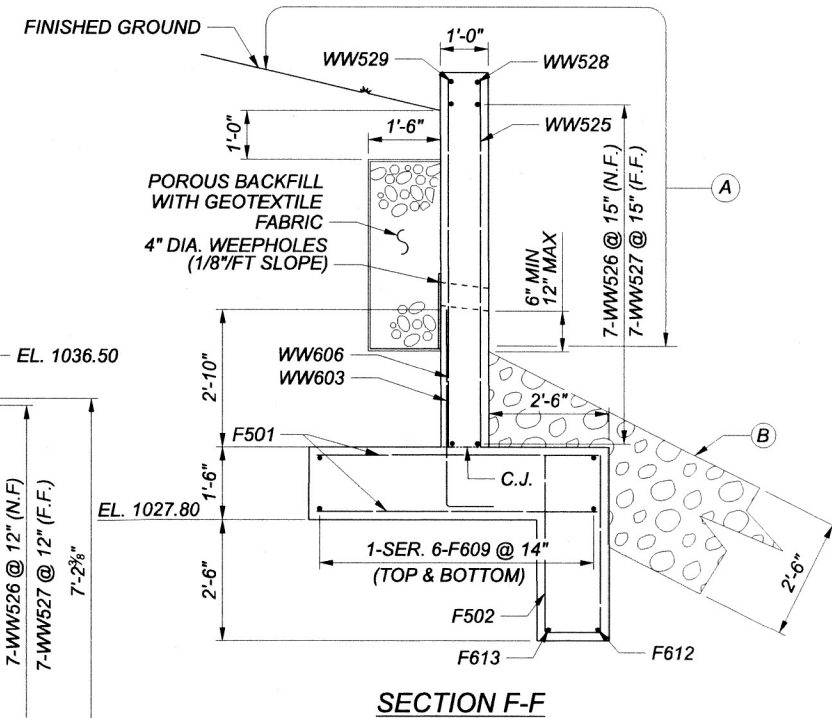
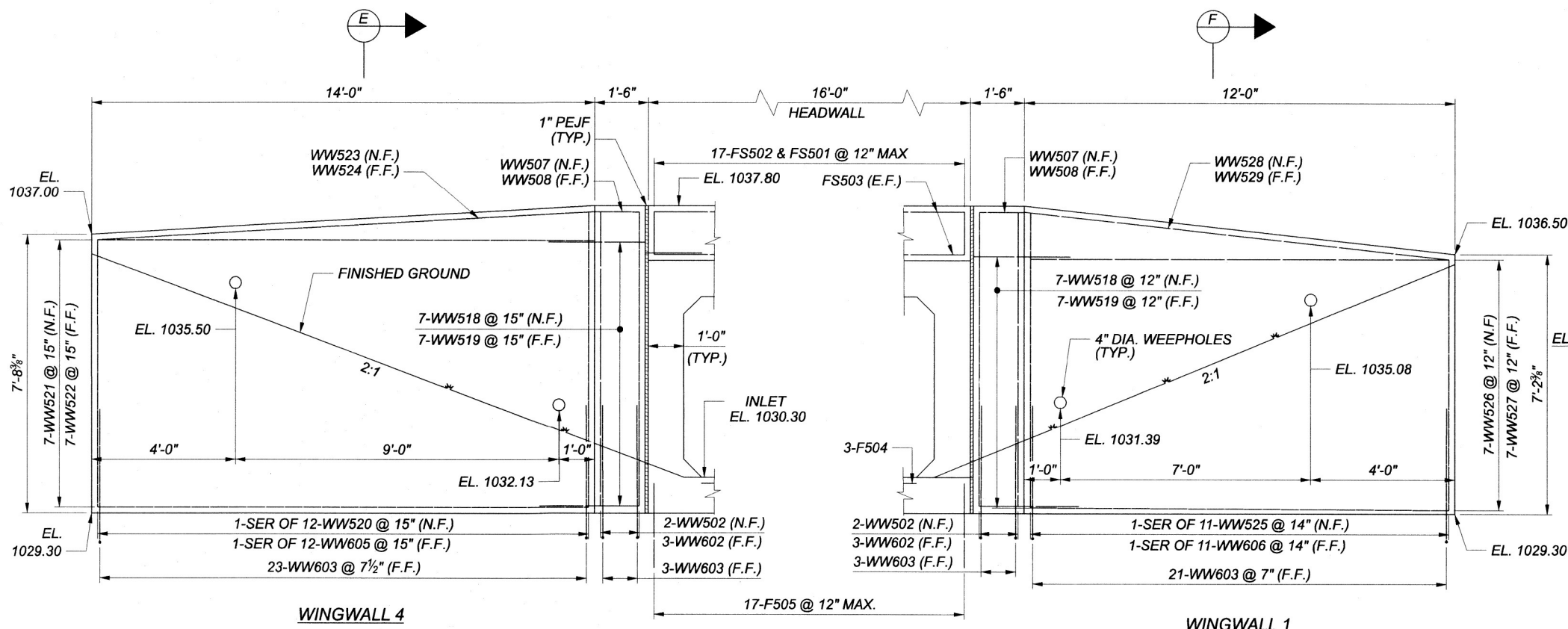
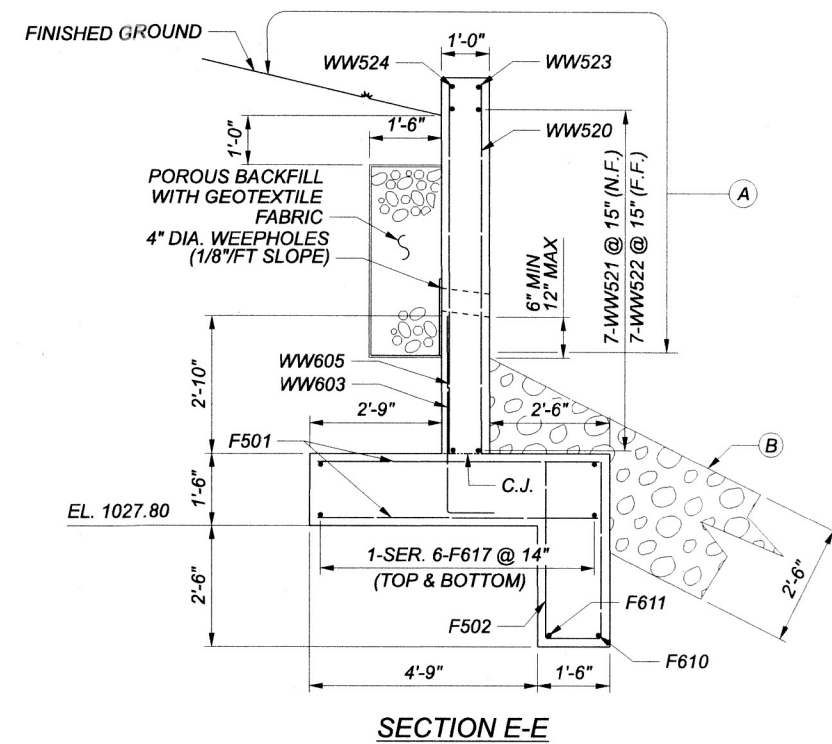
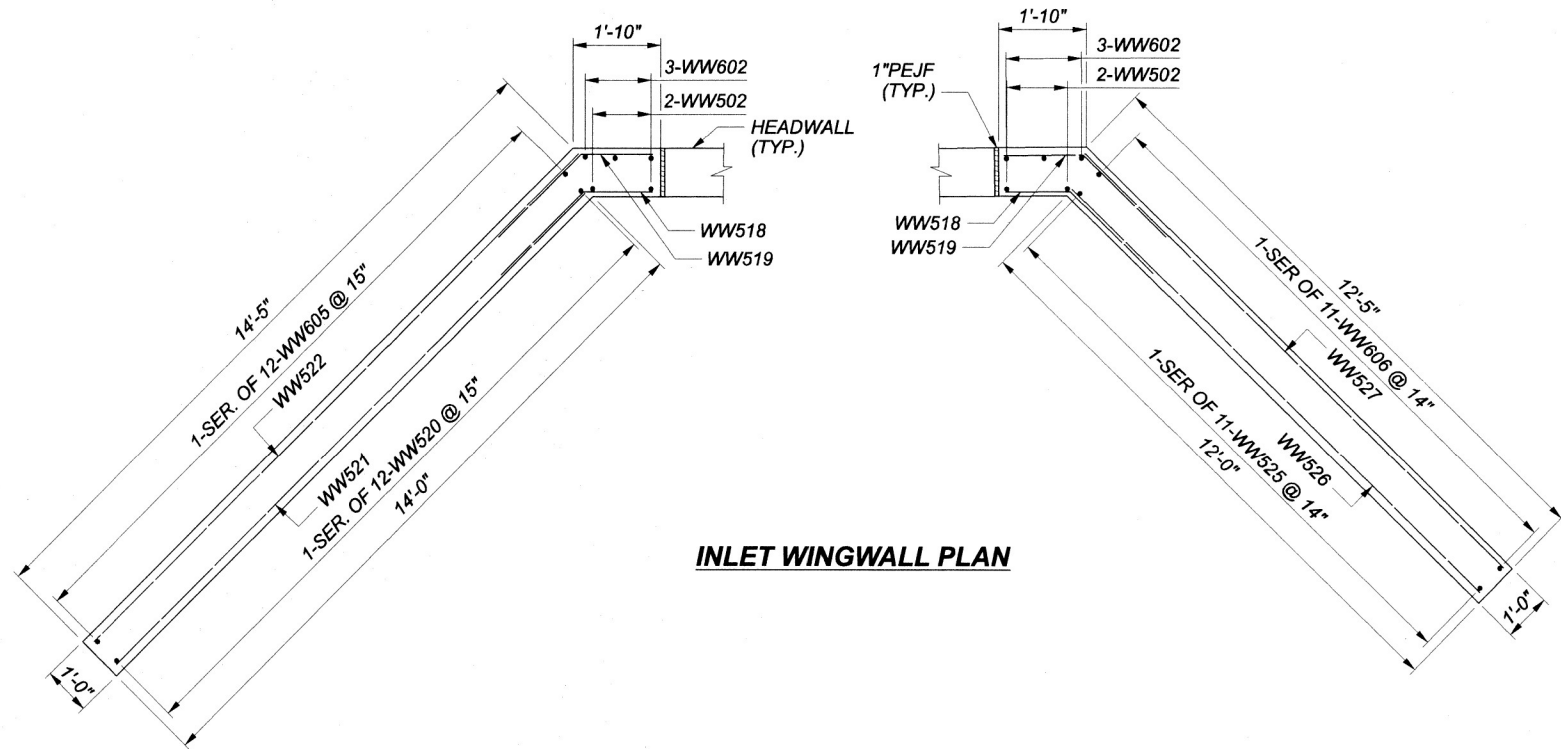

NOTES:

- FOR CULVERT PLAN AND PROFILE, SEE SHEET 3.
- FOR FOOTING SECTION, SEE SHEET 4.

LEGEND:

- (A) = SEALING OF CONCRETE SURFACES (NON-EPOXY)
- (B) = ROCK CHANNEL PROTECTION TYPE B, WITH GEOTEXTILE FABRIC 2'-6" THICK.

INLET WINGWALL DETAIL
 BRIDGE NO. HOL-00754-0.169
 S.R. 754 OVER UNNAMED TRIBUTARY OF PAINT CREEK

SFN	3803246
DESIGN AGENCY	B.G. Engineering Group, Inc.
DESIGNER	JEP
CHECKER	RG
REVIEWER	
GTB	7-14-22
PROJECT ID	111666
SUBSET	6
TOTAL	7
SHEET	70
TOTAL	93

MARK	NUMBER		LENGTH	WEIGHT	TYPE	DIMENSIONS					
	TOTAL					A	B	C	D	E	R
INLET FOOTING											
F501	86		5'-11"	531	STR						
F502	39		8'-1"	329	2	3'-7"	1'-2"	3'-7"			
F504	3		15'-8"	49	STR						
F505	17		5'-0"	89	1	2'-4"	2'-10"				
F609	2 SER. OF 6		11'-4" TO 13'-8"	225	STR						5 5/8"
F610	1		13'-4"	20	STR						
F611	1		13'-9"	21	STR						
F612	1		11'-4"	17	STR						
F613	1		11'-9"	18	STR						
F614	1		25'-6"	38	20	2'-9"	2'-9"	17'-9"	2'-9"	2'-9"	
F615	1		26'-7"	40	20	2'-9"	2'-9"	18'-10"	2'-9"	2'-9"	
F616	2 SER. OF 6		25'-6" TO 30'-6"	505	20	2'-9"	2'-9"	17'-9" TO 22'-9"	2'-9"	2'-9"	1'-0"
F617	2 SER. OF 6		13'-4" TO 15'-8"	261	STR						5 5/8"
SUBTOTAL				2,143							

MARK	NUMBER		LENGTH	WEIGHT	TYPE	DIMENSIONS					
	TOTAL					A	B	C	D	E	R
OUTLET FOOTING											
F501	64		5'-11"	395	STR						
F502	28		8'-1"	236	2	3'-7"	1'-2"	3'-7"			
F503	17		4'-4"	77	1	2'-4"	2'-2"				
F504	3		15'-8"	49	STR						
F601	2 SER. OF 6		5'-9" TO 8'-2"	125	STR						5 3/4"
F602	2 SER. OF 6		24'-7" TO 29'-4"	486	20	2'-9"	2'-9"	17'-0" TO 21'-9"	2'-10"	2'-6"	11 3/8"
F603	1		4'-10"	7	STR						
F604	1		5'-4"	8	STR						
F605	1		24'-7"	37	20	2'-9"	2'-9"	17'-0"	2'-10"	2'-6"	
F606	1		25'-9"	39	20	2'-9"	2'-9"	18'-2"	2'-10"	2'-6"	
F607	1		5'-9"	9	STR						
F608	1		6'-3"	9	STR						
F609	2 SER. OF 6		5'-0" TO 7'-0"	108	STR						4 3/4"
SUBTOTAL				1,585							

MARK	NUMBER		LENGTH	WEIGHT	TYPE	DIMENSIONS					
	TOTAL					A	B	C	D	E	R
HEADWALL											
FS501	34		3'-8"	130	2	1'-2"	8"	2'-1"			
FS502	34		2'-9"	98	2	1'-2"	8"	1'-2"			
FS503	8		15'-8"	131	STR						
SUBTOTAL				359							

MARK	NUMBER		LENGTH	WEIGHT	TYPE	DIMENSIONS					
	TOTAL					A	B	C	D	E	R
WINGWALL											
WW501	1 SER. OF 6		5'-8" TO 7'-9"	42	STR						5"
WW502	8		8'-2"	68	STR						
WW503	6		5'-10"	37	STR						
WW504	6		6'-2"	39	STR						
WW505	7		3'-9"	27	19	1'-3"	1'-11"	1'-8"			
WW506	7		4'-0"	29	19	1'-6"	1'-11"	1'-8"			
WW507	4		1'-3"	5	STR						
WW508	4		1'-6"	6	STR						
WW509	2		2'-9"	6	STR						
WW510	1		6'-4"	7	STR						
WW511	1		6'-8"	7	STR						
WW512	1 SER. OF 6		5'-8" TO 7'-9"	42	STR						5"
WW513	6		6'-10"	43	STR						
WW514	6		7'-2"	45	STR						
WW515	2		3'-3"	7	STR						
WW516	1		7'-3"	8	STR						
WW517	1		7'-8"	8	STR						
WW518	21		3'-8"	80	19	1'-3"	1'-9"	1'-9"			
WW519	21		4'-0"	88	19	1'-7"	1'-9"	1'-9"			
WW520	1 SER. OF 12		7'-3" TO 8'-1"	96	STR						0 7/8"
WW521	7		13'-9"	100	STR						
WW522	7		14'-2"	103	STR						
WW523	1		13'-11"	15	STR						
WW524	1		14'-6"	15	STR						
WW525	1 SER. OF 11		6'-10" TO 8'-1"	86	STR						1 1/2"
WW526	7		11'-11"	87	STR						
WW527	7		12'-3"	89	STR						
WW528	1		11'-11"	12	STR						
WW529	1		12'-3"	13	STR						
WW601	1 SER. OF 6		5'-8" TO 7'-9"	60	STR						5"
WW602	12		8'-2"	147	STR						
WW603	78		4'-9"	556	1	8"	4'-3"				
WW604	1 SER. OF 6		5'-8" TO 7'-9"	60	STR						5"
WW605	1 SER. OF 12		7'-3" TO 8'-1"	138	STR						0 7/8"
WW606	1 SER. OF 11		6'-10" TO 8'-1"	123	STR						1 1/2"
SUBTOTAL				2,294							

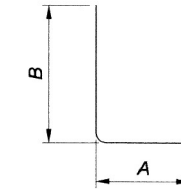

TYPE-1

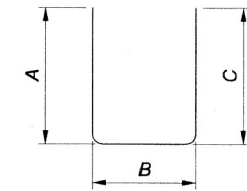

TYPE-2

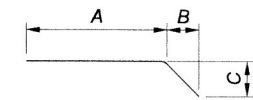

TYPE-19

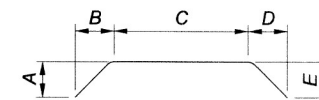

TYPE-20

NOTES:

- ALL REINFORCING STEEL SHALL BE EPOXY COATED.
- BAR SIZE: THE BAR SIZE IS INDICATED IN THE BAR MARK. THE MARK BEGINS WITH ONE OR TWO LETTERS THAT IDENTIFY THE BAR LOCATION. THE NEXT ONE OR TWO DIGITS INDICATES THE BAR SIZE, AND THE REMAINING TWO DIGITS ARE THE SEQUENCE NUMBER.

EXAMPLE: F501
F = FOOTING
5 = # 5 BAR
01 = BAR SEQUENCE NUMBER 1
- BAR DIMENSIONS SHOWN ARE OUT TO OUT UNLESS NOTED OTHERWISE.
- "STR" IN THE BAR TYPE COLUMN INDICATES A STRAIGHT BAR.
- "INC" INDICATES THE LENGTH INCREMENT FOR SERIES BARS.
- "SER" INDICATES A SERIES OF BARS.

HOL-39-1754-11.170.16, TJS-93-10.80

MODEL SHEET PAPER SIZE: 17x11 (in.) DATE: 7/14/2022 TIME: 1:15:22 PM USER: JPerchinske
 P:\Transportation\Work\111666_HOL-39-1118\400-Engineering\Structures\CEN_1982232\Sheets\111666_SG001.dgn

HYDRAULIC DATA	
DRAINAGE AREA:	0.21 SQ. MI.
EXISTING WATERWAY OPENING:	36.00 SF
PROPOSED WATERWAY OPENING:	36.00 SF
ORDINARY HIGH WATER MARK:	1046.00
DESIGN SERVICE LIFE:	75 YEARS
Ph:	6.7
ABRASION LEVEL: NON-ABRASIVE SITE	
Q ₁₀ = 70 CFS	Q ₁₀₀ = 138 CFS
V ₁₀ = 9.70 FPS	V ₁₀₀ = 11.65 FPS
H ₁₀ = 1047.05	H ₁₀₀ = 1048.18

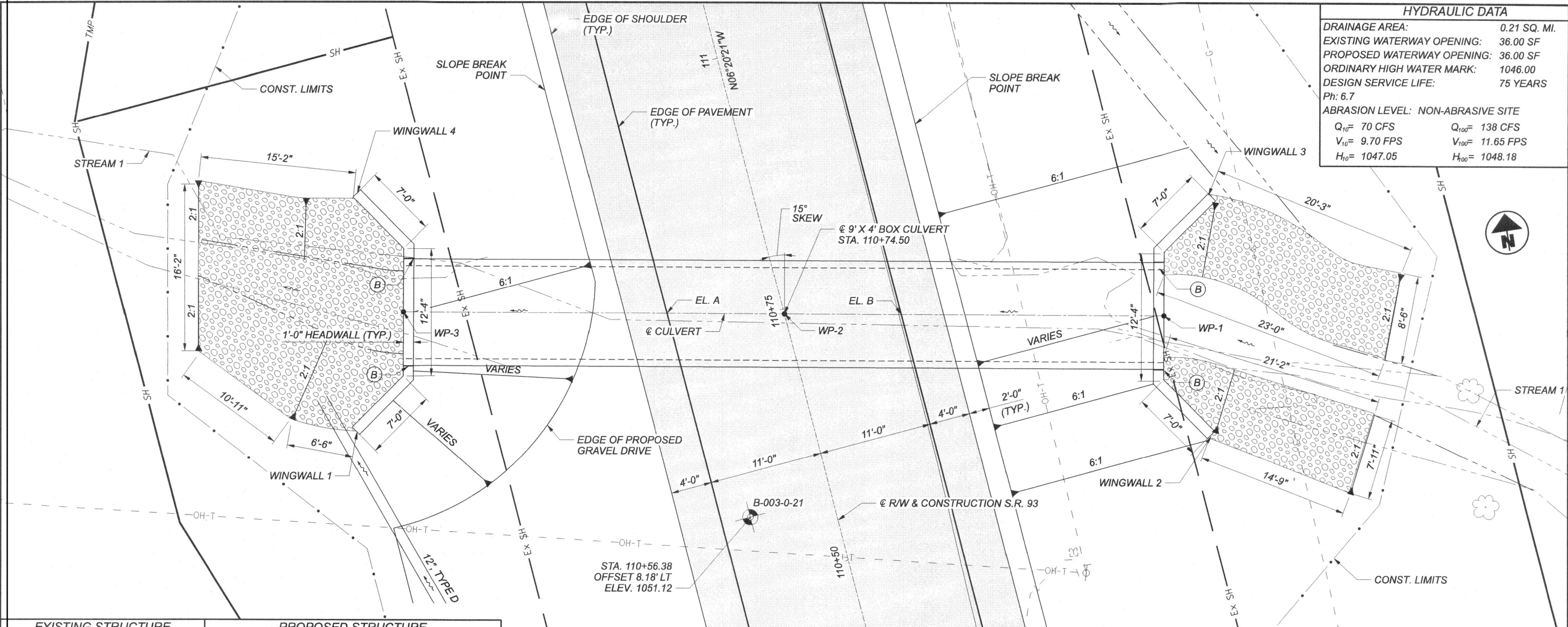

EXISTING STRUCTURE	PROPOSED STRUCTURE
TYPE: 9' X 4' CONCRETE BOX CULVERT	TYPE: 9' X 4' CONCRETE BOX CULVERT
SKEW: 14°	SKEW: 15°
ALIGNMENT: VARIES	ALIGNMENT: TANGENT
CFN: 1803971	ROADWAY WIDTH: 22'-0" PAVED SHLDR/SHLDR
CONDITION: POOR	LOADING: HL-93 AND 60 PSF FUTURE WEARING SURFACE
DISPOSITION: TO BE REPLACED	DESIGN SERVICE LIFE: 75 YEAR
	CFN: 1982232

POINT	STATION	OFFSET
WP-1	110+64.93	35.71' RT
WP-2	110+74.50	0.00
WP-3	110+84.09	35.77' LT

PLAN

- (A) SEE SHEET 2 FOR TYPICAL PAVEMENT BUILD-UP
- (B) 1" PEJF WITH MEMBRANE WATERPROOFING

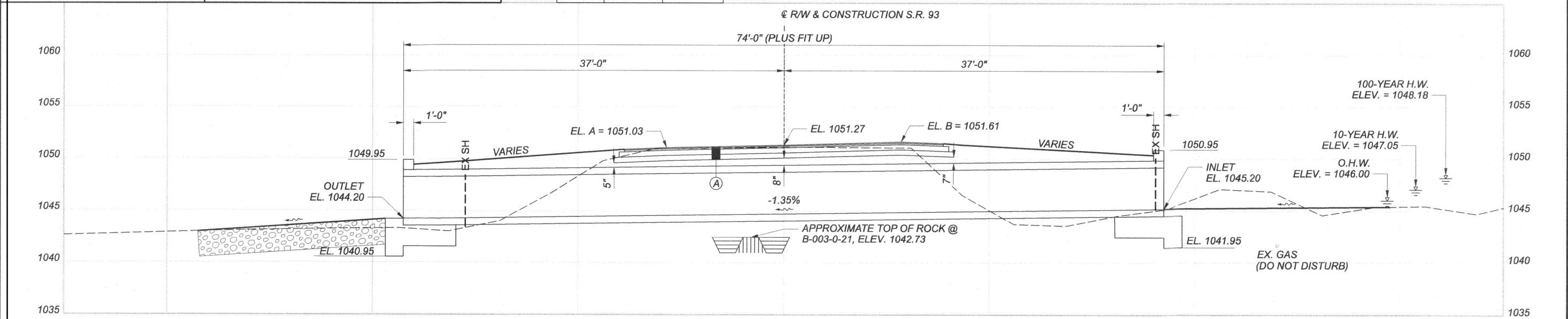
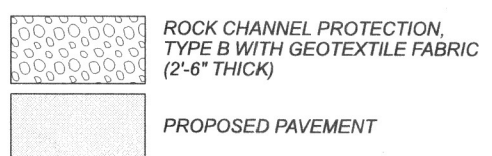

PROFILE ALONG @ CULVERT

CULVERT PLAN AND PROFILE
 CULVERT NO. TUS-00093-10.809
 S.R. 93 OVER UNNAMED TRIBUTARY OF SOUTH FORK SUGAR CREEK

CFN	1982232
DESIGN AGENCY	B.G. Engineering Group, Inc. 5910 WILCOX PLACE, SUITE C DUBLIN, OHIO 43016
DESIGNER	JEP
CHECKER	RG
REVIEWER	GTB
PROJECT ID	111666
SUBSET	TOTAL
1	6
SHEET	TOTAL
72	93

HOL-39-1754-11.17/0.16, TUS-93-10.80
 MODEL: Sheet PAPER SIZE: 17x11 (in.) DATE: 7/14/2022 TIME: 1:15:35 PM USER: JPerchinski
 P:\Transportation\Work\39-1118\400-Engineering\Structures\CFN_1982232\Sheets\111666_TUS-93-1081_CFN_1982232_S4001.dgn

GENERAL NOTES:

DESIGN SPECIFICATION:

THE STRUCTURE CONFORMS TO "LRFD BRIDGE DESIGN SPECIFICATIONS" ADOPTED BY THE AMERICAN ASSOCIATION OF STATE HIGHWAY AND TRANSPORTATION OFFICIALS, 9TH EDITION, 2020 AND THE ODOT BRIDGE DESIGN MANUAL, 2020

DESIGN DATA:

THE FOLLOWING DESIGN DATA IS ASSUMED:
 INTERNAL ANGLE OF FRICTION, (ϕ_{bf}) = 30°
 TOTAL UNIT WEIGHT OF BACKFILL SOIL = 120 PCF
 INTERNAL ANGLE OF FRICTION (DRAINED), FOUNDATION SOIL, ϕ_f = 28°
 UNDRAINED SHEAR STRENGTH (COHESIVE), FOUNDATION SOIL, S_{uf} = 1500 PSF
 UNIT WEIGHT OF CONCRETE = 150 PCF
 SLOPE OF BACKFILL = 2:1 (TYPE A & B HEADWALLS)
 HEIGHT OF LIVE LOAD SURCHARGE = 2 FT (TYPE C HEADWALLS)

CONCRETE CLASS QC1 - REQUIRED COMPRESSIVE STRENGTH 4000 PSI (FOOTING, WINGWALL AND FORESLOPE WALL)

REINFORCING STEEL - ASTM A615, A616, OR A617
 GRADE 60 MINIMUM YIELD STRENGTH
 60,000 PSI (ALL REINFORCING SHALL BE EPOXY COATED)

BASED ON THE ASSUMED DESIGN DATA, THE WINGWALLS ACHIEVE FACTORED BEARING RESISTANCES THAT ARE GREATER THAN THEIR RESPECTIVE BEARING PRESSURES. IF A BACKFILL MATERIAL WITH A HIGHER INTERNAL ANGLE OF FRICTION OR A LIGHTER TOTAL WEIGHT IS USED; OF IF A FOUNDATION SOIL WITH A HIGHER DRAINED INTERNAL ANGLE OF FRICTION OR A HIGHER UNDRAINED SHEAR STRENGTH IS ENCOUNTERED, THEN THE STABILITY OF THE WINGWALLS IS SATISFACTORY.

FORESLOPE WALL ANCHOR DOWELS:

AS AN ALTERNATIVE TO RESIN BONDING, THREADED INSERTS OR NONPROTRUDING MECHANICAL CONNECTORS CAST INTO THE CULVERT BY THE MANUFACTURER MAY BE USED PROVIDED THEY CAN RESIST AN ULTIMATE PULL-OUT STRENGTH OF 12 KIPS AND MAINTAIN A MINIMUM COVER OF 3 INCHES AT THE BOTTOM OF THE CULVERT SLAB. MECHANICAL CONNECTORS MUST PROVIDE AN "L-SHAPED" BAR INSIDE THE CULVERT WITH A MINIMUM HORIZONTAL LENGTH OF 12 INCHES. PAYMENT FOR INSERTS OR MECHANICAL CONNECTORS SHALL BE INCLUDED WITH ITEM 611.

TYPICAL ABBREVIATIONS:

- C.J. - CONSTRUCTION JOINT
- CLR. - CLEAR
- DIA. - DIAMETER
- E.F. - EACH FACE
- EQ. - EQUAL
- F.F. - FAR FACE
- INV. - INVERT
- PEJF. - PREFORMED EXPANSION JOINT FILLER
- MIN. - MINIMUM
- N.F. - NEAR FACE
- SPA. - SPACING / SPACE
- T - TOP
- B - BOTTOM
- T&B - TOP AND BOTTOM
- TYP. - TYPICAL

POROUS BACKFILL WITH GEOTEXTILE FABRIC:

POROUS BACKFILL WITH GEOTEXTILE FABRIC 1'-6" THICK SHALL BE PLACED BEHIND THE WINGWALLS ONLY AND SHALL EXTEND TO 12" BELOW THE EMBANKMENT SURFACE. GEOTEXTILE FABRIC SHALL BE PLACED BETWEEN THE POROUS BACKFILL AND REPLACED EXCAVATION ADJACENT TO THE STRUCTURE. IT SHALL TURN UNDER THE BOTTOM OF THE POROUS BACKFILL AND RETURN 6" ABOVE THE TOP ELEVATION OF THE WEEPHOLE. WEEPHOLES SHALL BE PLACED 6" TO 12" ABOVE THE NORMAL WATER ELEVATION OR GROUND LINE AND SHALL HAVE A MAXIMUM SPACING OF 10'-0". A MINIMUM OF ONE WEEPHOLE SHALL BE PROVIDED PER WINGWALL.

ITEM 611 - 9' X 4' CONDUIT, TYPE A, 706.05, AS PER PLAN

ALL REQUIREMENTS OF 706.05 SHALL BE MET. THE 30 DAY WAITING PERIOD PER C&MS 611.12 SHALL BE WAIVED. IN LIEU OF THE BACKFILL REQUIREMENTS OF C&MS 611.06, PROVIDE LOW STRENGTH MORTAR BACKFILL TO THE LIMITS AS DETAILED ON THIS SHEET.

PREFORMED EXPANSION JOINT FILLER:

PREFORMED EXPANSION JOINT FILLER: PREFORMED EXPANSION JOINT FILLER (PEJF) CONFORMING TO CMS 705.03, 1 INCH THICK, SHALL BE PLACED ABOVE THE FOOTING BETWEEN THE SIDES OF THE BOX CULVERT AND THE ENDS OF THE WINGWALLS. PAYMENT FOR MATERIALS AND INSTALLATION SHALL BE INCLUDED WITH ITEM 516 - 1" PREFORMED EXPANSION JOINT FILLER.

SEALING OF FORESLOPE WALL AND WINGWALLS:

ALL EXPOSED FORESLOPE WALL AND WINGWALL CONCRETE SHALL BE SEALED WITH EPOXY-URETHANE SEALER. THE LIMITS SHALL BE AS SHOWN IN THE DIAGRAMS BELOW. PAYMENT FOR THE EPOXY-URETHANE SEALER SHALL BE PER ITEM 512 - SEALING OF CONCRETE SURFACES, (EPOXY-URETHANE).

WATERPROOFING:

TYPE 2 WATERPROOFING, PER CMS 512.09 AND 711.25, SHALL EXTEND VERTICALLY DOWN THE ENTIRE SIDES OF THE PRECAST CULVERT SECTIONS FOR ALL PORTIONS OF THE CULVERT WHICH SHALL BE IN CONTACT WITH THE BACKFILL. PAYMENT FOR THE MEMBRANE WATERPROOFING SHALL BE AT THE CONTRACT PRICE BID PER SQUARE YARD FOR ITEM 512 - TYPE 2 WATERPROOFING.

IF PAVEMENT IS NOT PLACED DIRECTLY ON TOP OF THE CULVERT, TYPE 2 WATERPROOFING, PER CMS 512.09 AND 711.25 SHALL BE APPLIED TO THE ENTIRE TOP SURFACE OF THE PRECAST CULVERT SECTIONS AND SHALL EXTEND ONE FOOT VERTICALLY DOWN THE SIDES FOR ALL PORTIONS OF THE CULVERT WHICH SHALL BE IN CONTACT WITH THE BACKFILL. PAYMENT FOR THE MEMBRANE WATERPROOFING SHALL BE AT THE CONTRACT PRICE BID PER SQUARE YARD FOR ITEM 512 - TYPE 2 WATERPROOFING.

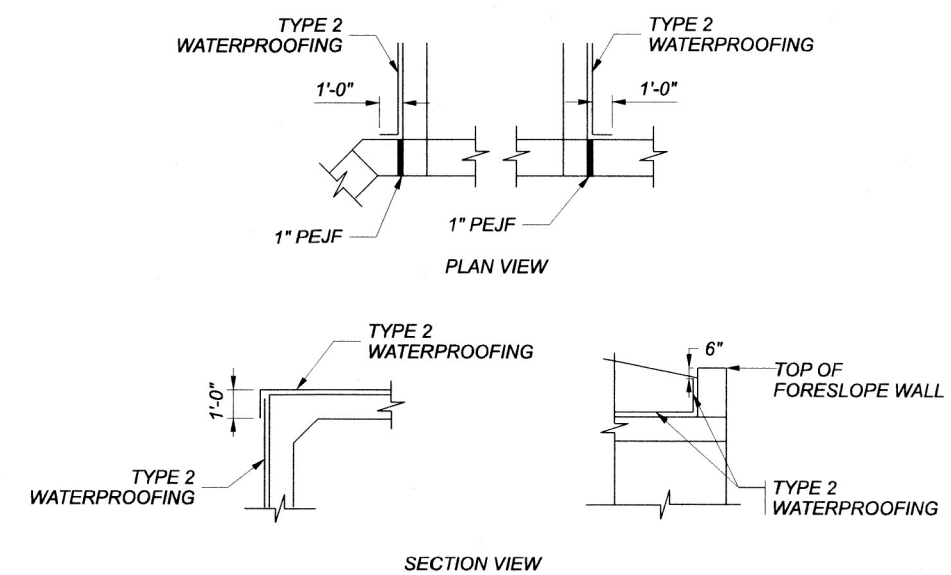
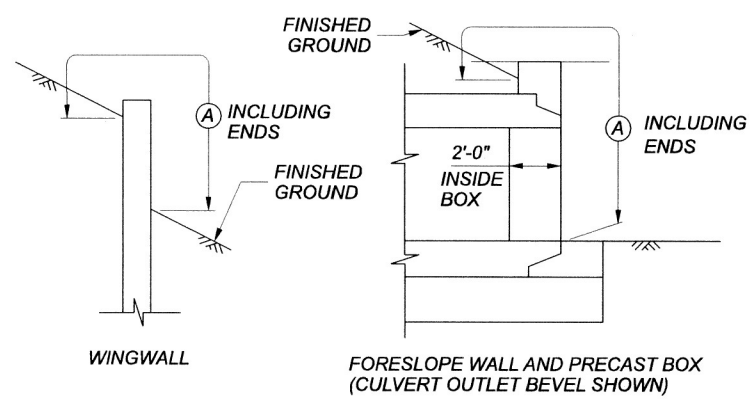

LIMITS OF ITEM 512-SEALING CONCRETE SURFACES WITH (EPOXY-URETHANE)

(A) - SEAL ENTIRE CONCRETE SURFACE AREA

ITEM 613 - LOW STRENGTH MORTAR BACKFILL

TO BE PLACED FROM END TO END OF POROUS BACKFILL.

CALCULATION:
 LEFT SIDE = $[2' + (2' + 4')] / 2 \times 4' \times 69' / 27 = 40.89$ C.Y.
 RIGHT SIDE = $[2' + (2' + 4')] / 2 \times 4' \times 69' / 27 = 40.89$ C.Y.

TOTAL = 81.78 C.Y. (USE 82 C.Y.)
 (01/STR/CV)

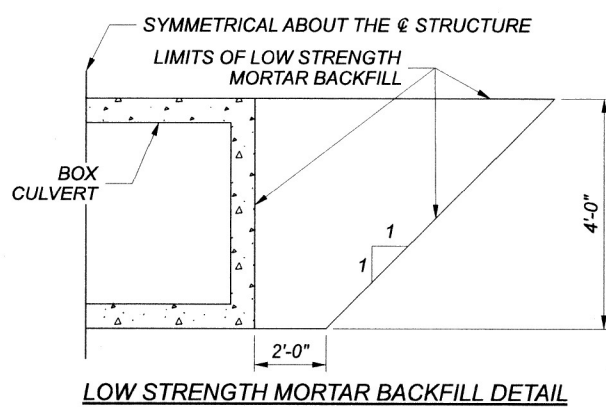

ESTIMATED QUANTITIES				DESIGNED:	RG	CHECKED:	GTB
ITEM	TOTAL	UNIT	DESCRIPTION	DATE:	7/12/2022	DATE:	7/13/2022
202	LUMP		STRUCTURE REMOVED				
503	LUMP		COFFERDAMS AND EXCAVATION BRACING				
503	56	CY	UNCLASSIFIED EXCAVATION, INCLUDING ROCK				
509	3508	LB	EPOXY COATED REINFORCING STEEL				
511	8	CY	CLASS QC1 CONCRETE, RETAINING/WINGWALL NOT INCLUDING FOOTING				
511	22	CY	CLASS QC1 CONCRETE, FOOTING				
511	1	CY	CLASS QC1 CONCRETE, HEADWALL				
512	42	SY	SEALING OF CONCRETE SURFACES (EPOXY-URETHANE)				
512	194	SY	TYPE 2 WATERPROOFING				
516	26	SF	1" PREFORMED EXPANSION JOINT FILLER				
518	8	CY	POROUS BACKFILL WITH GEOTEXTILE FABRIC				
611	74	FT	9' X 4' CONDUIT, TYPE A, 706.05				
613	82	CY	LOW STRENGTH MORTAR BACKFILL				

TOTAL QUANTITIES ARE CARRIED TO THE GENERAL SUMMARY ON SHEET 18.

GENERAL NOTES AND ESTIMATED QUANTITIES

CULVERT NO. TUS-00093-10-809
 S.R. 93 OVER UNNAMED TRIBUTARY OF SOUTH FORK SUGAR CREEK

CFN	1982232
DESIGN AGENCY	BG
DESIGNER	JEP
CHECKER	RG
REVIEWER	GTB
PROJECT NO.	111666
SUBSET	2
TOTAL	6
SHEET	73
TOTAL	93

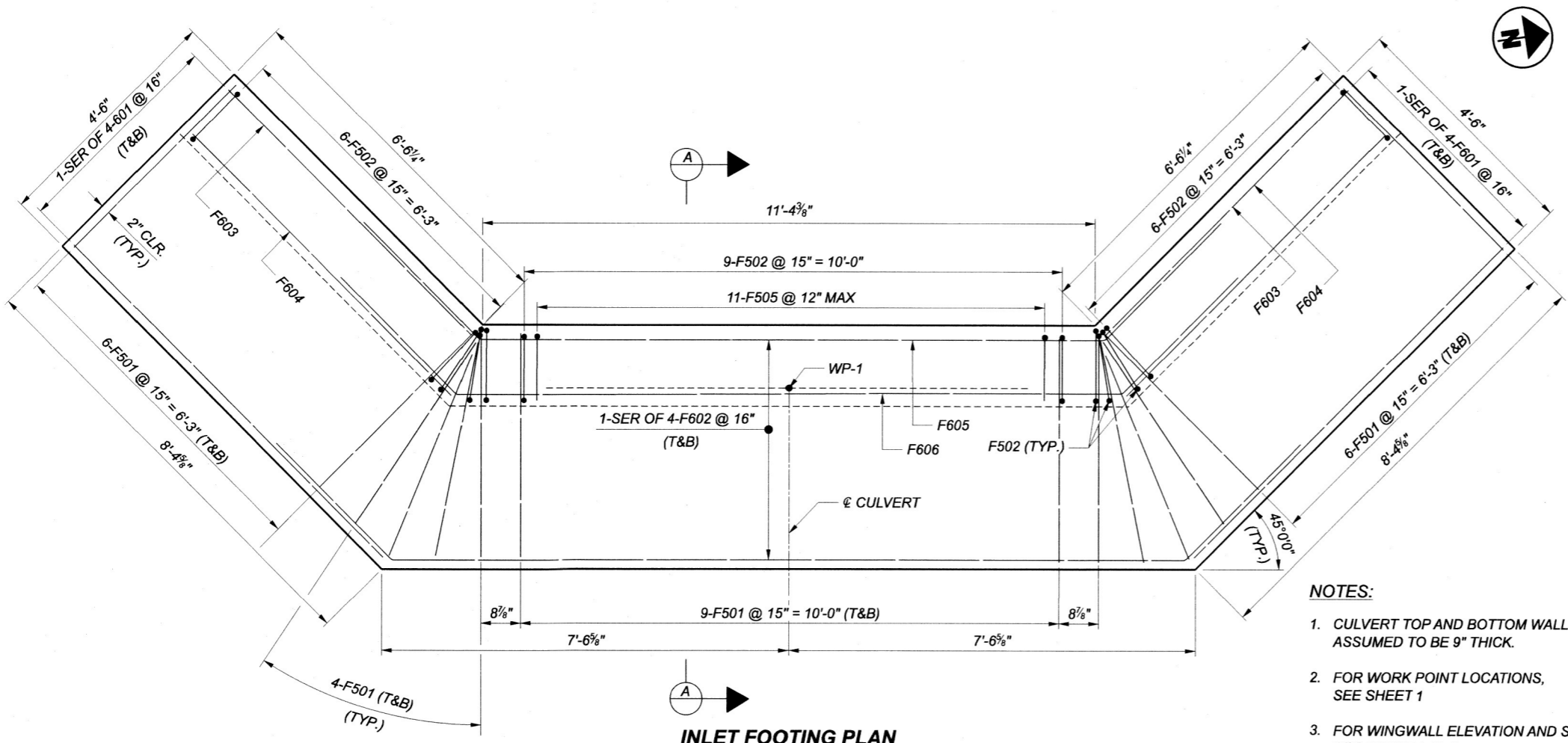

INLET FOOTING PLAN
(CULVERT NOT SHOWN)

MINIMUM LAP LENGTH:
 # 5 BAR = 2'-6"
 # 6 BAR = 3'-0"

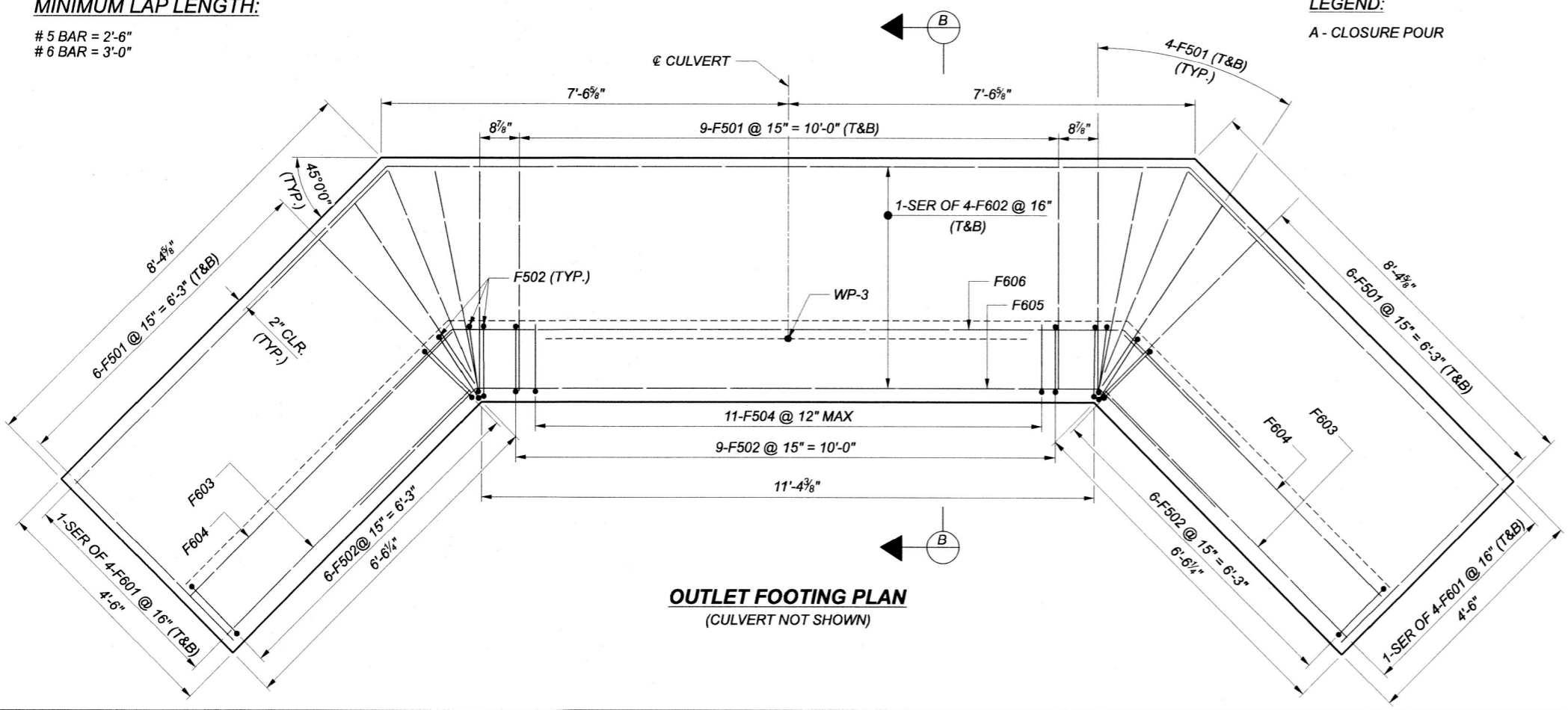

OUTLET FOOTING PLAN
(CULVERT NOT SHOWN)

- NOTES:**
1. CULVERT TOP AND BOTTOM WALLS ASSUMED TO BE 9" THICK.
 2. FOR WORK POINT LOCATIONS, SEE SHEET 1
 3. FOR WINGWALL ELEVATION AND SECTIONS, SEE SHEET 4 & 5.
- LEGEND:**
 A - CLOSURE POUR

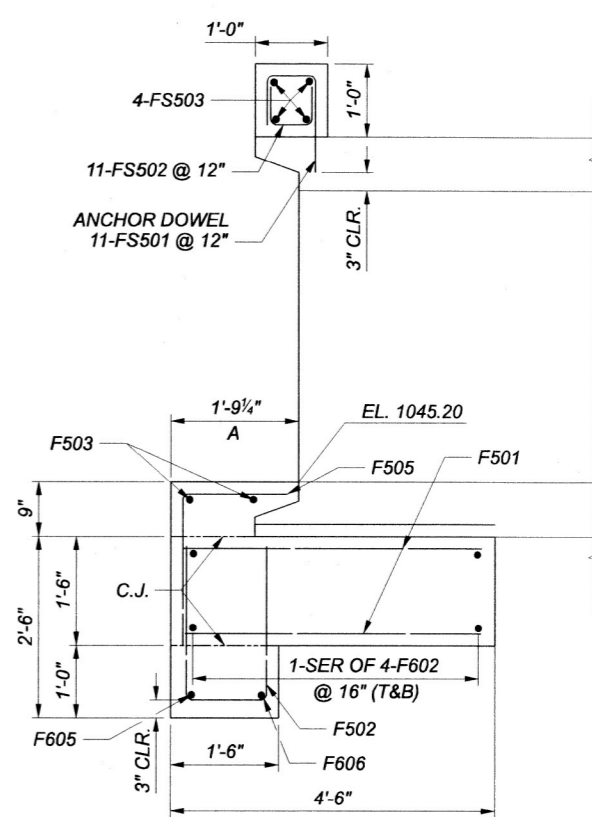

SECTION A-A
(INLET)

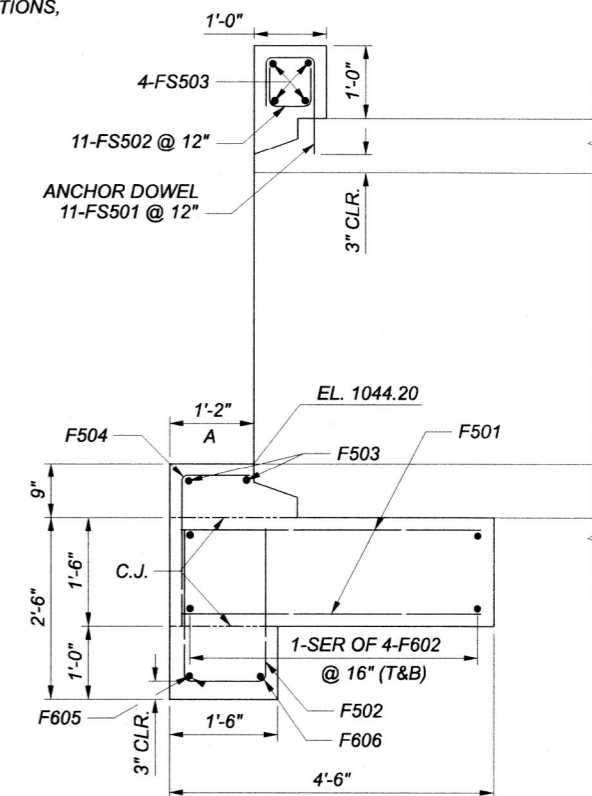

SECTION B-B
(OUTLET)

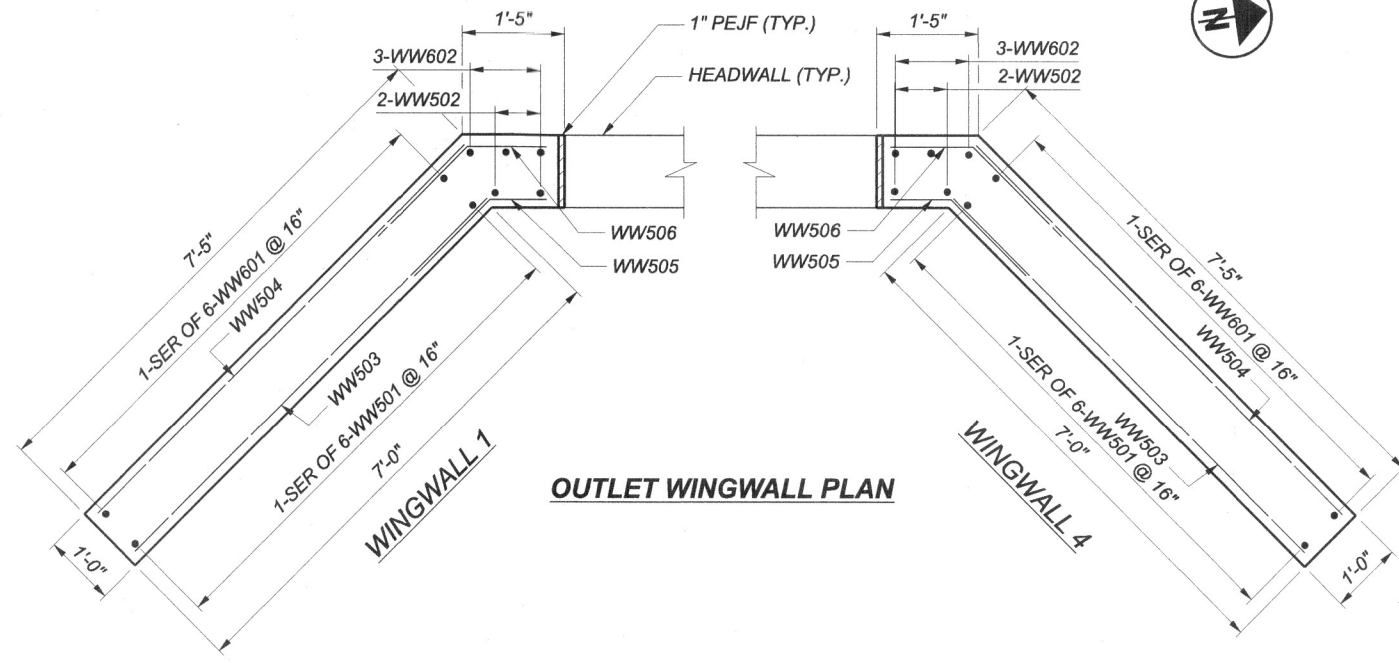

OUTLET WINGWALL PLAN

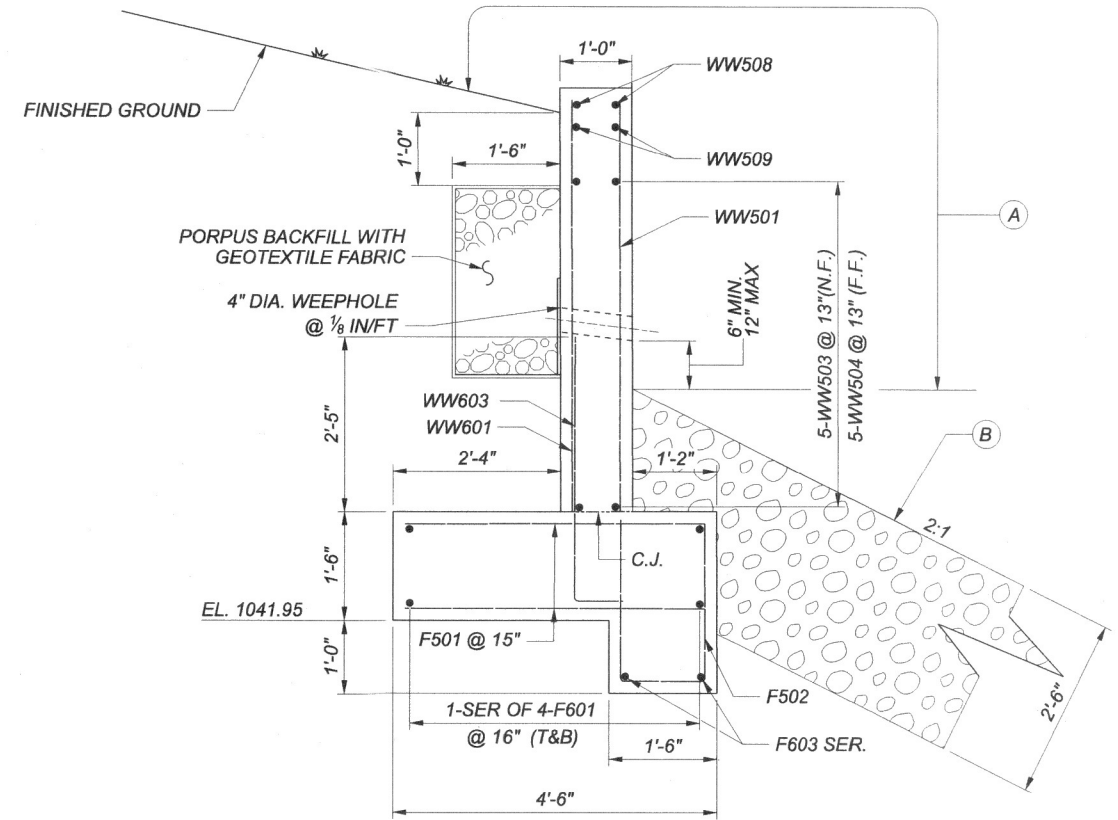

SECTION B-B

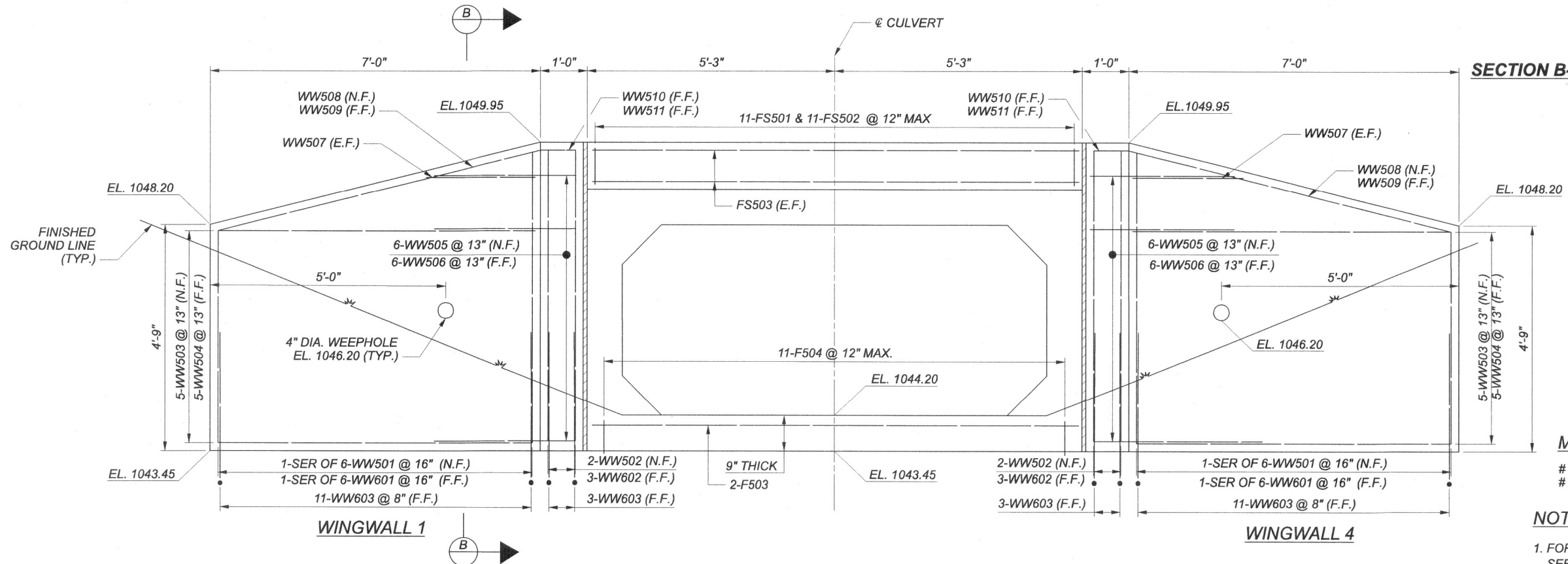

OUTLET WINGWALL ELEVATION

MINIMUM LAP LENGTH:

- # 5 BAR = 2'-6"
- # 6 BAR = 3'-0"

NOTES:

1. FOR CULVERT PLAN AND PROFILE, SEE SHEET 1.
2. FOR FOOTING SECTION, SEE SHEET 3.

LEGEND:

- (A) = SEALING OF CONCRETE SURFACES (NON-EPOXY)
- (B) = ROCK CHANNEL PROTECTION TYPE B, WITH GEOTEXTILE FABRIC 2'-6" THICK

CFN	1982232
DESIGN AGENCY	B.G. GROUP, INC.
DESIGNER	JEP
CHECKER	RG
REVIEWER	
GTB	7-14-22
PROJECT ID	111666
SUBSET	TOTAL
4	6
SHEET	TOTAL
75	93

HOL-39-1754-11.170.16, TUS-93-10.80

MODEL: Sheet PAPER SIZE: 17x11 (in.) DATE: 7/14/2022 TIME: 1:16:01 PM USER: JPerchinski
 P:\Transportation\Work\111666_HOL-39-1118400-Engineering\Structures\CFN_1982232\Sheet\111666_TUS-93-1081_CFN_1982232_SM002.dgn

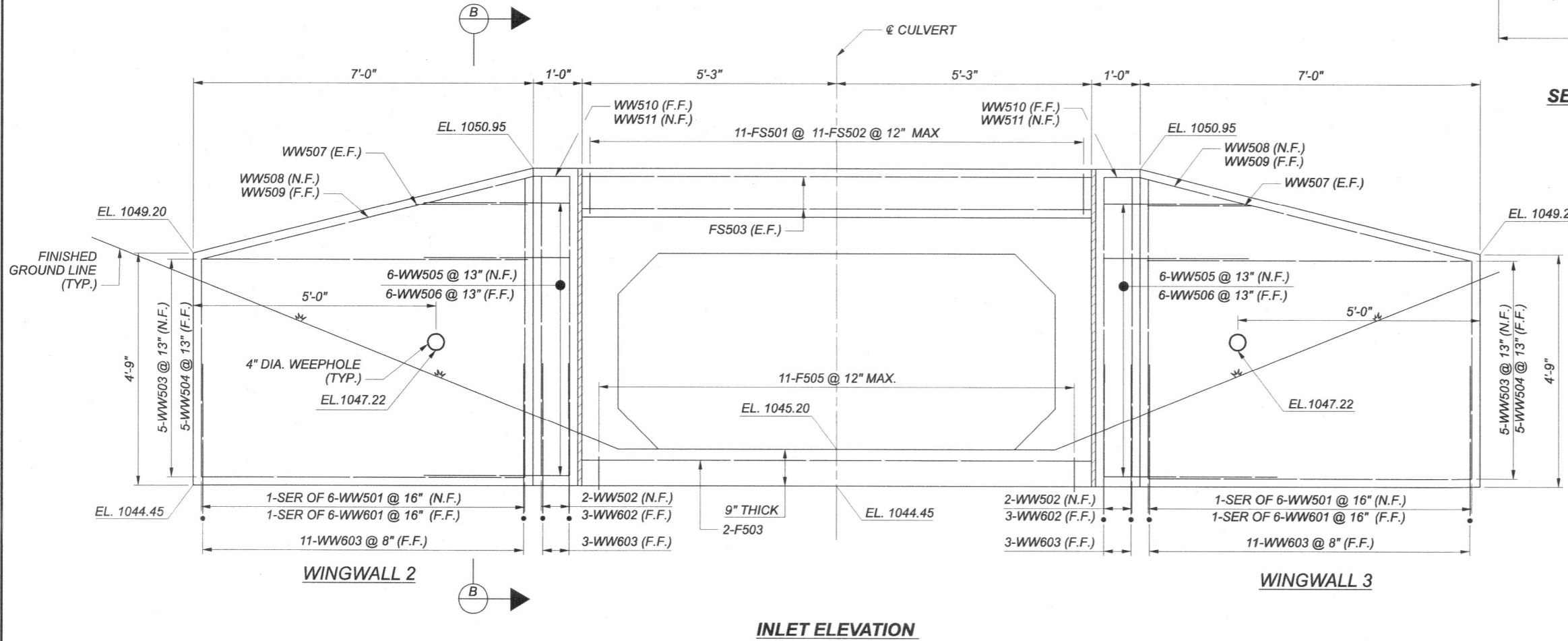
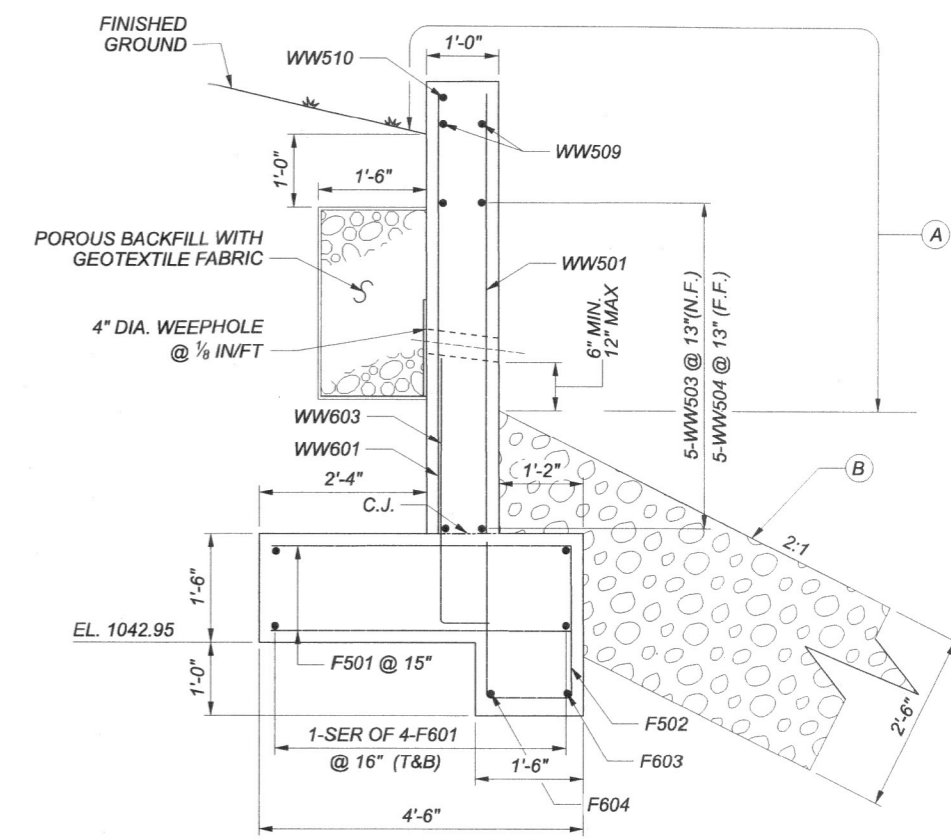
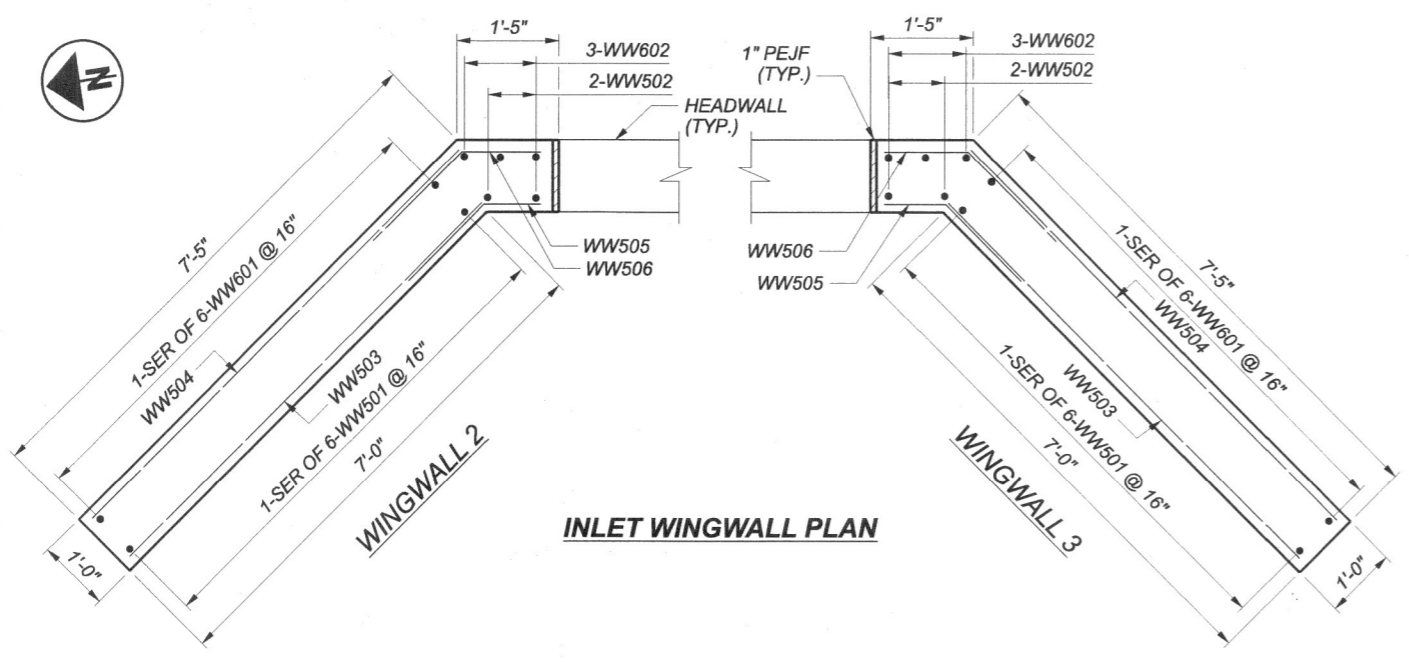

MINIMUM LAP LENGTH:
 # 5 BAR = 2'-6"
 # 6 BAR = 3'-0"

NOTES:
 1. FOR CULVERT PLAN AND PROFILE, SEE SHEET 1.
 2. FOR FOOTING SECTION, SEE SHEET 3.

LEGEND:
 (A) = SEALING OF CONCRETE SURFACES (NON-EPOXY)
 (B) = ROCK CHANNEL PROTECTION TYPE B, WITH GEOTEXTILE FABRIC 2'-6" THICK

INLET WINGWALL DETAIL
CULVERT NO. TUS-00093-10.809
S.R. 93 OVER UNNAMED TRIBUTARY OF SOUTH FORK SUGAR CREEK

CFN	1982232
DESIGN AGENCY	B.G. GROUP, INC. 5810 WILCOX PLACE, SUITE C DUBLIN, OHIO 43016
DESIGNER	JEP
CHECKER	RG
REVIEWER	GTB
PROJECT ID	111666
SUBSET	5
TOTAL	6
SHEET	76
TOTAL	93

MARK	NUMBER		LENGTH	WEIGHT	TYPE	DIMENSIONS						
	TOTAL					A	B	C	D	E	R	INC
OUTLET FOOTING												
F501	58		4'-2"	252	STR							
F502	27		5'-1"	143	2	2'-1"	1'-2"	2'-1"				
F503	2		10'-2"	21	STR							
F504	11		2'-7"	30	1	10"	1'-11"					
F601	4 SER. OF 4		6'-4" TO 8'-2"	174	STR							7 3/8"
F602	2 SER. OF 4		17'-7" TO 20'-10"	231	20	2'-2"	2'-2"	11'-6" TO 14'-9"	2'-2"	2'-2"		1'-1"
F603	2		6'-4"	19	STR							
F604	2		6'-10"	21	STR							
F605	1		17'-10"	27	20	2'-3"	2'-3"	11'-6"	2'-3"	2'-3"		
F606	1		18'-9"	28	20	2'-3"	2'-3"	12'-5"	2'-3"	2'-3"		
SUBTOTAL				946								

MARK	NUMBER		LENGTH	WEIGHT	TYPE	DIMENSIONS						
	TOTAL					A	B	C	D	E	R	INC
INLET FOOTING												
F501	58		4'-2"	252	STR							
F502	27		5'-1"	143	2	2'-1"	1'-2"	2'-1"				
F503	2		10'-2"	21	STR							
F505	11		3'-2"	36	1	1'-5"	1'-11"					
F601	4 SER. OF 4		6'-4" TO 8'-2"	174	STR							7 3/8"
F602	2 SER. OF 4		17'-7" TO 21'-0"	232	20	2'-2"	2'-2"	11'-6" TO 14'-11"	2'-2"	2'-2"		1'-1 3/8"
F603	2		6'-4"	19	STR							
F604	2		6'-10"	21	STR							
F605	1		17'-10"	27	20	2'-3"	2'-3"	11'-6"	2'-3"	2'-3"		
F606	1		18'-9"	28	20	2'-3"	2'-3"	12'-5"	2'-3"	2'-3"		
SUBTOTAL				953								

MARK	NUMBER		LENGTH	WEIGHT	TYPE	DIMENSIONS						
	TOTAL					A	B	C	D	E	R	INC
WINGWALLS												
WW501	4 SER. OF 6		4'-5" TO 6'-1"	131	STR							4"
WW502	8		6'-2"	51	STR							
WW503	20		6'-10"	143	STR							
WW504	20		7'-2"	149	STR							
WW505	24		3'-3"	81	19	10"	1'-9"	1'-9"				
WW506	24		3'-7"	90	19	1'-2"	1'-9"	1'-9"				
WW507	8		2'-1"	17	STR							
WW508	4		6'-10"	29	STR							
WW509	4		7'-3"	30	STR							
WW510	4		1'-1"	5	STR							
WW511	4		10"	3	STR							
WW601	4 SER. OF 6		4'-5" TO 6'-1"	189	STR							4"
WW602	12		6'-2"	111	STR							
WW603	56		4'-9"	400	1	8"	4'-3"					
SUBTOTAL				1,429								

MARK	NUMBER		LENGTH	WEIGHT	TYPE	DIMENSIONS						
	TOTAL					A	B	C	D	E	R	INC
HEADWALL												
FS501	22		2'-5"	55	2	8"	8"	1'-4"				
FS502	22		1'-9"	40	2	8"	8"	8"				
FS503	8		10'-2"	85	STR							
SUBTOTAL				180								

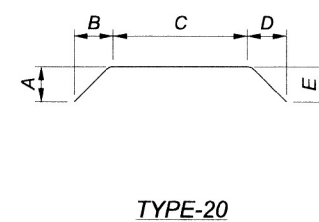
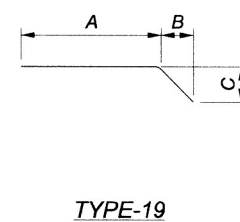
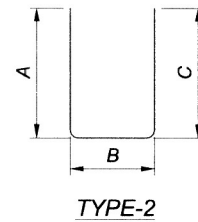
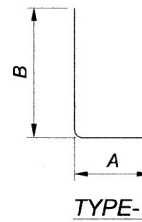

NOTES :

- ALL REINFORCING STEEL SHALL BE EPOXY COATED.
- BAR SIZE: THE BAR SIZE IS INDICATED IN THE BAR MARK. THE MARK BEGINS WITH ONE OR TWO LETTERS THAT IDENTIFY THE BAR LOCATION. THE NEXT ONE OR TWO DIGITS INDICATES THE BAR SIZE, AND THE REMAINING TWO DIGITS ARE THE SEQUENCE NUMBER.
 EXAMPLE: F501
 F = FOOTING
 5 = # 5 BAR
 01 = BAR SEQUENCE NUMBER 1
- BAR DIMENSIONS SHOWN ARE OUT TO OUT UNLESS NOTED OTHERWISE.
- "STR" IN THE BAR TYPE COLUMN INDICATES A STRAIGHT BAR.
- "INC" INDICATES THE LENGTH INCREMENT FOR SERIES BARS.
- "SER." INDICATES A SERIES OF BARS.

REINFORCING STEEL LIST
 CULVERT NO. TUS-00093-10.809
 S.R. 93 OVER UNNAMED TRIBUTARY OF SOUTH FORK SUGAR CREEK

CFN	1982232
DESIGN AGENCY	BG
DESIGNER	JEP
CHECKER	RG
REVIEWER	
GTB	7-14-22
PROJECT ID	111666
SUBSET	TOTAL
6	6
SHEET	TOTAL
77	93